

# Bridgelux® SMD 7070 10.6W 36V

Product Data Sheet D213

# Introduction

SMD 7070

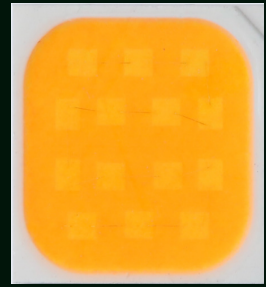

The Bridgelux SMD 7070 high power LED is hot-color targeted, which ensures that the LEDs fall within their specified color bin at the typical application conditions of 85°C. With its broad lumen coverage and wide range of CCT options, the SMD 7070 provides unparalleled design-in flexibility for indoor and outdoor lighting applications (for example: street light, high bay, flood light). The SMD 7070 is ideal as a drop-in replacement for emitters with an industry standard 7.0mm x 7.0mm footprint.

## Features

- Industry-standard 7070 footprint
- 3 bin options enable tight color control
- Enables 3- and 5-step MacAdam ellipse custom binning kits
- RoHS compliant and lead free
- Multiple CCT configurations available for a wide range of lighting applications

## Benefits

- Lower operating and manufacturing costs
- Ease of design and rapid go-to-market
- Uniform, consistent white light
- Reliable and constant white point
- Environmentally friendly, complies with standards
- Design flexibility

# Contents

Product Feature Map	2
Product Nomenclature	2
Product Test Conditions	2
Product Selection Guide	3
Performance at Commonly Used Drive Currents	5
Electrical Characteristics	8
Absolute Maximum Ratings	9
Product Bin Definitions	10
Performance Curves	13
Typical Radiation Pattern	16
Typical Color Spectrum	17
Mechanical Dimensions	18
Reliability	19
Reflowing Characteristics	20
Packaging	21
Design Resources	23
Precautions	23
Disclaimers	23
About Bridgelux	24

# Product Feature Map

Bridgelux SMD LED products come in industry standard package sizes and follow ANSI binning standards. These LEDs are optimized for cost and performance, helping to ensure highly competitive system lumen per dollar performance while addressing the stringent efficacy and reliability standards required for modern lighting applications. Please visit [www.bridgelux.com](http://www.bridgelux.com) for more information.

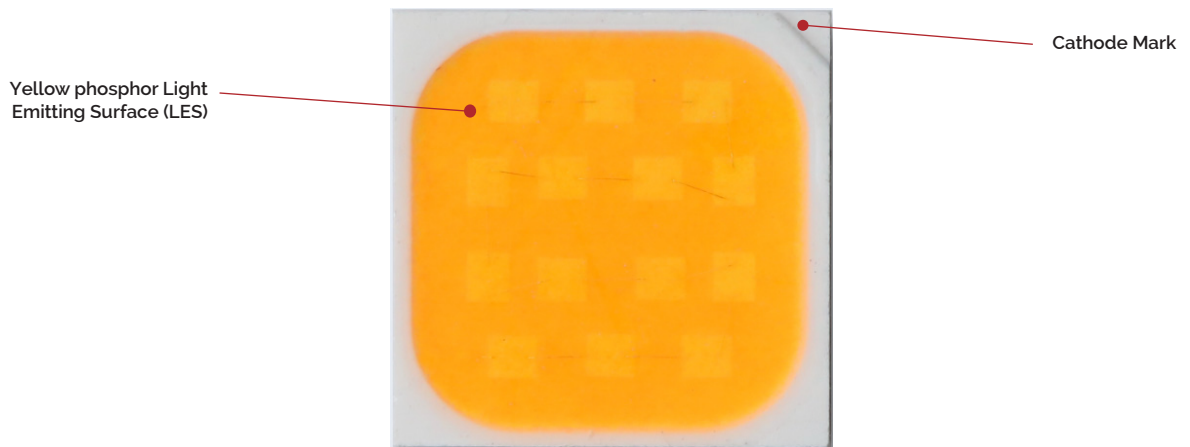

## Product Nomenclature

The part number designation for Bridgelux SMD 7070 is explained as follows:

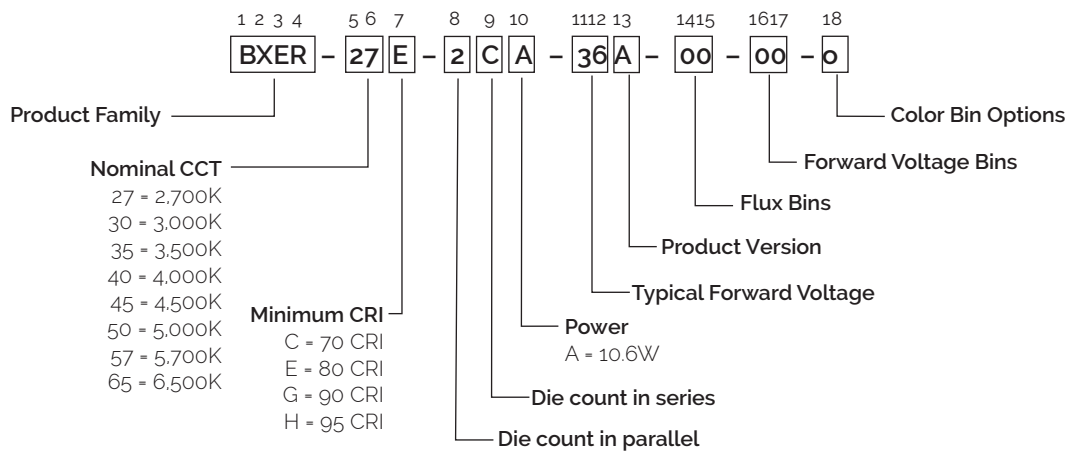

## Product Test Conditions

Bridgelux SMD 7070 LEDs are tested and binned with a 10ms pulse of 300mA at  $T_j$  (junction temperature) =  $T_{sp}$  (solder point temperature) = 25°C. Forward voltage and luminous flux are binned at a  $T_j = T_{sp} = 25^\circ\text{C}$ , while color is hot targeted at a  $T_{sp}$  of 85°C.

# Product Selection Guide

The following product configurations are available:

**Table 1:** Selection Guide, Pulsed Measurement Data at 300mA ( $T_j = T_{sp} = 25^\circ\text{C}$ )

Part Number <sup>1,6</sup>	Nominal CCT <sup>2</sup> (K)	CRI <sup>3,5</sup>	Nominal Drive Current (mA)	Forward Voltage <sup>4,5</sup> (V)			Typical Pulsed Flux (lm) <sup>4,5</sup>	Typical Power (W)	Typical Efficacy (lm/W)
				Min	Typical	Max			
BXER-27C-2CA-36A-00-00-0	2700	70	300	33.6	35.5	39.8	1620	10.6	152
BXER-27E-2CA-36A-00-00-0	2700	80	300	33.6	35.5	39.8	1439	10.6	135
BXER-27G-2CA-36A-00-00-0	2700	90	300	33.6	35.5	39.8	1216	10.6	114
BXER-27H-2CA-36A-00-00-0	2700	95	300	33.6	35.5	39.8	1077	10.6	101
BXER-30C-2CA-36A-00-00-0	3000	70	300	33.6	35.5	39.8	1659	10.6	156
BXER-30E-2CA-36A-00-00-0	3000	80	300	33.6	35.5	39.8	1474	10.6	138
BXER-30G-2CA-36A-00-00-0	3000	90	300	33.6	35.5	39.8	1251	10.6	117
BXER-30H-2CA-36A-00-00-0	3000	95	300	33.6	35.5	39.8	1116	10.6	105
BXER-35C-2CA-36A-00-00-0	3500	70	300	33.6	35.5	39.8	1699	10.6	160
BXER-35E-2CA-36A-00-00-0	3500	80	300	33.6	35.5	39.8	1521	10.6	143
BXER-40C-2CA-36A-00-00-0	4000	70	300	33.6	35.5	39.8	1723	10.6	162
BXER-40E-2CA-36A-00-00-0	4000	80	300	33.6	35.5	39.8	1568	10.6	147
BXER-40G-2CA-36A-00-00-0	4000	90	300	33.6	35.5	39.8	1345	10.6	126
BXER-40H-2CA-36A-00-00-0	4000	95	300	33.6	35.5	39.8	1155	10.6	108
BXER-45C-2CA-36A-00-00-0	4500	70	300	33.6	35.5	39.8	1723	10.6	162
BXER-45E-2CA-36A-00-00-0	4500	80	300	33.6	35.5	39.8	1568	10.6	147
BXER-50C-2CA-36A-00-00-0	5000	70	300	33.6	35.5	39.8	1723	10.6	162
BXER-50E-2CA-36A-00-00-0	5000	80	300	33.6	35.5	39.8	1568	10.6	147
BXER-57C-2CA-36A-00-00-0	5700	70	300	33.6	35.5	39.8	1711	10.6	161
BXER-57E-2CA-36A-00-00-0	5700	80	300	33.6	35.5	39.8	1568	10.6	147
BXER-65C-2CA-36A-00-00-0	6500	70	300	33.6	35.5	39.8	1685	10.6	158
BXER-65E-2CA-36A-00-00-0	6500	80	300	33.6	35.5	39.8	1563	10.6	147

Notes for Table 1:

- The last 7 characters (including hyphens '-') refer to flux bins, forward voltage bins, and color bin options, respectively. "00-00-0" denotes the full distribution of flux, forward voltage, and 5 SDCM color.  
Example: BXER-27E-2CA-36A-00-00-0 refers to the full distribution of flux, forward voltage, and color within a 2700K 5-step ANSI standard chromaticity region with a minimum of 80CRI, 2x12 die configuration, 10.6w power, 35.5V typical forward voltage.
- Product CCT is hot targeted at  $T_{sp} = 85^\circ\text{C}$ . Nominal CCT as defined by ANSI C78.377-2011.
- Listed CRIs are minimum values and include test tolerance.
- Products tested under pulsed condition (10ms pulse width) at nominal drive current where  $T_j = T_{sp} = 25^\circ\text{C}$ .
- Bridgelux maintains a  $\pm 7.5\%$  tolerance on luminous flux measurements,  $\pm 0.1\text{V}$  tolerance on forward voltage measurements, and  $\pm 2$  tolerance on CRI measurements for the SMD 7070.
- Refer to Table 6 and Table 7 for Bridgelux SMD 7070 Luminous Flux Binning and Forward Voltage Binning information.

# Product Selection Guide

The following product configurations are available:

**Table 2:** Selection Guide, Stabilized DC Performance ( $T_{sp} = 85^{\circ}\text{C}$ )<sup>6,7</sup>

Part Number <sup>1,5</sup>	Nominal CCT <sup>2</sup> (K)	CRI <sup>3,4</sup>	Nominal Drive Current (mA)	Forward Voltage <sup>4</sup> (V)			Typical DC Flux (lm) <sup>4</sup>	Typical Power (W)	Typical Efficacy (lm/W)
				Min	Typical	Max			
BXER-27C-2CA-36A-00-00-0	2700	70	300	32.6	34.5	38.8	1400	10.4	135
BXER-27E-2CA-36A-00-00-0	2700	80	300	32.6	34.5	38.8	1244	10.4	120
BXER-27G-2CA-36A-00-00-0	2700	90	300	32.6	34.5	38.8	1051	10.4	102
BXER-27H-2CA-36A-00-00-0	2700	95	300	32.6	34.5	38.8	931	10.4	90
BXER-30C-2CA-36A-00-00-0	3000	70	300	32.6	34.5	38.8	1435	10.4	139
BXER-30E-2CA-36A-00-00-0	3000	80	300	32.6	34.5	38.8	1274	10.4	123
BXER-30G-2CA-36A-00-00-0	3000	90	300	32.6	34.5	38.8	1082	10.4	104
BXER-30H-2CA-36A-00-00-0	3000	95	300	32.6	34.5	38.8	965	10.4	93
BXER-35C-2CA-36A-00-00-0	3500	70	300	32.6	34.5	38.8	1469	10.4	142
BXER-35E-2CA-36A-00-00-0	3500	80	300	32.6	34.5	38.8	1315	10.4	127
BXER-40C-2CA-36A-00-00-0	4000	70	300	32.6	34.5	38.8	1489	10.4	144
BXER-40E-2CA-36A-00-00-0	4000	80	300	32.6	34.5	38.8	1356	10.4	131
BXER-40G-2CA-36A-00-00-0	4000	90	300	32.6	34.5	38.8	1163	10.4	112
BXER-40H-2CA-36A-00-00-0	4000	95	300	32.6	34.5	38.8	999	10.4	97
BXER-45C-2CA-36A-00-00-0	4500	70	300	32.6	34.5	38.8	1489	10.4	144
BXER-45E-2CA-36A-00-00-0	4500	80	300	32.6	34.5	38.8	1355	10.4	131
BXER-50C-2CA-36A-00-00-0	5000	70	300	32.6	34.5	38.8	1489	10.4	144
BXER-50E-2CA-36A-00-00-0	5000	80	300	32.6	34.5	38.8	1355	10.4	131
BXER-57C-2CA-36A-00-00-0	5700	70	300	32.6	34.5	38.8	1479	10.4	143
BXER-57E-2CA-36A-00-00-0	5700	80	300	32.6	34.5	38.8	1356	10.4	131
BXER-65C-2CA-36A-00-00-0	6500	70	300	32.6	34.5	38.8	1457	10.4	141
BXER-65E-2CA-36A-00-00-0	6500	80	300	32.6	34.5	38.8	1351	10.4	131

Notes for Table 2:

- The last 7 characters (including hyphens '-') refer to flux bins, forward voltage bins, and color bin options, respectively. "00-00-0" denotes the full distribution of flux, forward voltage, and 5 SDCM color.  
Example: BXER-27E-2CA-36A-00-00-0 refers to the full distribution of flux, forward voltage, and color within a 2700K 5-step ANSI standard chromaticity region with a minimum of 80CRI, 2x12 die configuration, 10.6w power, 35.5V typical forward voltage.
- Product CCT is hot targeted at  $T_{sp} = 85^{\circ}\text{C}$ . Nominal CCT as defined by ANSI C78.377-2011.
- Listed CRIs are minimum values and include test tolerance.
- Bridgelux maintains a  $\pm 7.5\%$  tolerance on luminous flux measurements,  $\pm 0.1\text{V}$  tolerance on forward voltage measurements, and  $\pm 2$  tolerance on CRI measurements for the SMD 7070.
- Refer to Table 6 and Table 7 for Bridgelux SMD 7070 Luminous Flux Binning and Forward Voltage Binning information.
- Typical stabilized DC performance values are provided as reference only and are not a guarantee of performance.
- Typical performance is estimated based on operation under DC (direct current) with LED emitter mounted onto a heat sink with thermal interface material and the solder point temperature maintained at  $85^{\circ}\text{C}$ . Based on Bridgelux test setup, values may vary depending on the thermal design of the luminaire and/or the exposed environment to which the product is subjected.

# Performance at Commonly Used Drive Currents

SMD 7070 LEDs are tested to the specifications shown using the nominal drive currents in Table 1. SMD 7070 may also be driven at other drive currents dependent on specific application design requirements. The performance at any drive current can be derived from the current vs. voltage characteristics shown in Figure 2 and the relative luminous flux vs. current characteristics shown in Figure 3. The performance at commonly used drive currents is summarized in Table 3.

**Table 3:** Performance at Commonly Used Drive Currents

Part Number	CRI	Drive Current <sup>1</sup> (mA)	Typical $V_f$ $T_{sp} = 25^\circ\text{C}$ (V)	Typical Power $T_{sp} = 25^\circ\text{C}$ (W)	Typical Pulsed Flux <sup>2</sup> $T_{sp} = 25^\circ\text{C}$ (lm)	Typical DC Flux <sup>3</sup> $T_{sp} = 85^\circ\text{C}$ (lm)	Typical Efficacy $T_{sp} = 25^\circ\text{C}$ (lm/W)
BXER-27C-2CA-36A-00-00-0	70	100	32.5	3.3	594	541	182
		200	34.1	6.8	1129	1002	166
		<b>300</b>	<b>35.5</b>	<b>10.6</b>	<b>1620</b>	<b>1400</b>	<b>153</b>
		400	36.7	14.7	2070	1741	141
BXER-27E-2CA-36A-00-00-0	80	100	32.5	3.3	527	481	162
		200	34.1	6.8	1004	891	147
		<b>300</b>	<b>35.5</b>	<b>10.6</b>	<b>1439</b>	<b>1244</b>	<b>136</b>
		400	36.7	14.7	1839	1547	125
BXER-27G-2CA-36A-00-00-0	90	100	32.5	3.3	446	406	137
		200	34.1	6.8	848	752	124
		<b>300</b>	<b>35.5</b>	<b>10.6</b>	<b>1216</b>	<b>1051</b>	<b>115</b>
		400	36.7	14.7	1554	1307	106
BXER-27H-2CA-36A-00-00-0	95	100	32.5	3.3	395	360	121
		200	34.1	6.8	751	667	110
		<b>300</b>	<b>35.5</b>	<b>10.6</b>	<b>1077</b>	<b>931</b>	<b>102</b>
		400	36.7	14.7	1376	1158	94
BXER-30C-2CA-36A-00-00-0	70	100	32.5	3.3	608	554	187
		200	34.1	6.8	1157	1027	170
		<b>300</b>	<b>35.5</b>	<b>10.6</b>	<b>1659</b>	<b>1435</b>	<b>157</b>
		400	36.7	14.7	2121	1784	144
BXER-30E-2CA-36A-00-00-0	80	100	32.5	3.3	540	492	166
		200	34.1	6.8	1028	912	151
		<b>300</b>	<b>35.5</b>	<b>10.6</b>	<b>1474</b>	<b>1274</b>	<b>139</b>
		400	36.7	14.7	1884	1584	128
BXER-30G-2CA-36A-00-00-0	90	100	32.5	3.3	459	418	141
		200	34.1	6.8	872	774	128
		<b>300</b>	<b>35.5</b>	<b>10.6</b>	<b>1251</b>	<b>1082</b>	<b>118</b>
		400	36.7	14.7	1599	1345	109

Notes for Table 3:

1. Alternate drive currents in Table 3 are provided for reference only and are not a guarantee of performance.
2. Bridgelux maintains a  $\pm 7.5\%$  tolerance on flux measurements.
3. Typical stabilized DC performance values are provided as reference only and are not a guarantee of performance.

# Performance at Commonly Used Drive Currents

**Table 3:** Performance at Commonly Used Drive Currents

Part Number	CRI	Drive Current <sup>1</sup> (mA)	Typical $V_f$ $T_{sp} = 25^\circ\text{C}$ (V)	Typical Power $T_{sp} = 25^\circ\text{C}$ (W)	Typical Pulsed Flux <sup>2</sup> $T_{sp} = 25^\circ\text{C}$ (lm)	Typical DC Flux <sup>3</sup> $T_{sp} = 85^\circ\text{C}$ (lm)	Typical Efficacy $T_{sp} = 25^\circ\text{C}$ (lm/W)
BXER-30H-2CA-36A-00-00-0	95	100	32.5	3.3	409	373	126
		200	34.1	6.8	778	691	114
		<b>300</b>	<b>35.5</b>	<b>10.6</b>	<b>1116</b>	<b>965</b>	<b>105</b>
		400	36.7	14.7	1426	1199	97
BXER-35C-2CA-36A-00-00-0	70	100	32.5	3.3	623	568	191
		200	34.1	6.8	1185	1052	174
		<b>300</b>	<b>35.5</b>	<b>10.6</b>	<b>1699</b>	<b>1469</b>	<b>160</b>
		400	36.7	14.7	2172	1826	148
BXER-35E-2CA-36A-00-00-0	80	100	32.5	3.3	557	508	171
		200	34.1	6.8	1061	941	156
		<b>300</b>	<b>35.5</b>	<b>10.6</b>	<b>1521</b>	<b>1315</b>	<b>143</b>
		400	36.7	14.7	1944	1635	132
BXER-40C-2CA-36A-00-00-0	70	100	32.5	3.3	631	576	194
		200	34.1	6.8	1201	1066	176
		<b>300</b>	<b>35.5</b>	<b>10.6</b>	<b>1723</b>	<b>1489</b>	<b>163</b>
		400	36.7	14.7	2202	1852	150
BXER-40E-2CA-36A-00-00-0	80	100	32.5	3.3	575	524	177
		200	34.1	6.8	1093	970	160
		<b>300</b>	<b>35.5</b>	<b>10.6</b>	<b>1568</b>	<b>1356</b>	<b>148</b>
		400	36.7	14.7	2004	1685	136
BXER-40G-2CA-36A-00-00-0	90	100	32.5	3.3	493	449	151
		200	34.1	6.8	938	832	138
		<b>300</b>	<b>35.5</b>	<b>10.6</b>	<b>1345</b>	<b>1163</b>	<b>127</b>
		400	36.7	14.7	1719	1445	117
BXER-40H-2CA-36A-00-00-0	95	100	32.5	3.3	423	386	130
		200	34.1	6.8	806	715	118
		<b>300</b>	<b>35.5</b>	<b>10.6</b>	<b>1155</b>	<b>999</b>	<b>109</b>
		400	36.7	14.7	1476	1242	100
BXER-45C-2CA-36A-00-00-0	70	100	32.5	3.3	631	576	194
		200	34.1	6.8	1201	1066	176
		<b>300</b>	<b>35.5</b>	<b>10.6</b>	<b>1723</b>	<b>1489</b>	<b>163</b>
		400	36.7	14.7	2202	1852	150

Notes for Table 3:

1. Alternate drive currents in Table 3 are provided for reference only and are not a guarantee of performance.
2. Bridgelux maintains a  $\pm 7.5\%$  tolerance on flux measurements.
3. Typical stabilized DC performance values are provided as reference only and are not a guarantee of performance.



# Performance at Commonly Used Drive Currents

**Table 3:** Performance at Commonly Used Drive Currents

Part Number	CRI	Drive Current <sup>1</sup> (mA)	Typical $V_f$ $T_{sp} = 25^\circ\text{C}$ (V)	Typical Power $T_{sp} = 25^\circ\text{C}$ (W)	Typical Pulsed Flux <sup>2</sup> $T_{sp} = 25^\circ\text{C}$ (lm)	Typical DC Flux <sup>3</sup> $T_{sp} = 85^\circ\text{C}$ (lm)	Typical Efficacy $T_{sp} = 25^\circ\text{C}$ (lm/W)
BXER-45E-2CA-36A-00-00-0	80	100	32.5	3.3	575	524	177
		200	34.1	6.8	1093	970	160
		<b>300</b>	<b>35.5</b>	<b>10.6</b>	<b>1568</b>	<b>1355</b>	<b>148</b>
		400	36.7	14.7	2004	1685	136
BXER-50C-2CA-36A-00-00-0	70	100	32.5	3.3	631	576	194
		200	34.1	6.8	1201	1066	176
		<b>300</b>	<b>35.5</b>	<b>10.6</b>	<b>1723</b>	<b>1489</b>	<b>163</b>
		400	36.7	14.7	2202	1852	150
BXER-50E-2CA-36A-00-00-0	80	100	32.5	3.3	575	524	177
		200	34.1	6.8	1093	970	160
		<b>300</b>	<b>35.5</b>	<b>10.6</b>	<b>1568</b>	<b>1355</b>	<b>148</b>
		400	36.7	14.7	2004	1685	136
BXER-57C-2CA-36A-00-00-0	70	100	32.5	3.3	627	572	193
		200	34.1	6.8	1193	1059	175
		<b>300</b>	<b>35.5</b>	<b>10.6</b>	<b>1711</b>	<b>1479</b>	<b>161</b>
		400	36.7	14.7	2187	1839	149
BXER-57E-2CA-36A-00-00-0	80	100	32.5	3.3	575	524	177
		200	34.1	6.8	1093	970	160
		<b>300</b>	<b>35.5</b>	<b>10.6</b>	<b>1568</b>	<b>1356</b>	<b>148</b>
		400	36.7	14.7	2004	1685	136
BXER-65C-2CA-36A-00-00-0	70	100	32.5	3.3	618	563	190
		200	34.1	6.8	1175	1043	172
		<b>300</b>	<b>35.5</b>	<b>10.6</b>	<b>1685</b>	<b>1457</b>	<b>159</b>
		400	36.7	14.7	2154	1811	147
BXER-65E-2CA-36A-00-00-0	80	100	32.5	3.3	573	522	176
		200	34.1	6.8	1090	967	160
		<b>300</b>	<b>35.5</b>	<b>10.6</b>	<b>1563</b>	<b>1351</b>	<b>147</b>
		400	36.7	14.7	1998	1680	136

Notes for Table 3:

1. Alternate drive currents in Table 3 are provided for reference only and are not a guarantee of performance.
2. Bridgelux maintains a  $\pm 7.5\%$  tolerance on flux measurements.
3. Typical stabilized DC performance values are provided as reference only and are not a guarantee of performance.

# Electrical Characteristics

**Table 4:** Electrical Characteristics

Part Number <sup>1</sup>	Drive Current (mA)	Forward Voltage (V) <sup>2,3</sup>			Typical Temperature Coefficient of Forward Voltage $\Delta V_f / \Delta T$ (mV/°C)	Typical Thermal Resistance Junction to Solder Point <sup>4</sup> $R_{j-sp}$ (°C/W)
		Minimum	Typical	Maximum		
BXER-XXX-2CA-36A-00-00-0	300	33.6	35.5	39.8	-11.2	1.4

Notes for Table 4:

- The last 7 characters (including hyphens '-') refer to flux bins, forward voltage bins, and color bin options, respectively. "00-00-0" denotes the full distribution of flux, forward voltage, and 5 SDCM color.  
Example: BXER-27E-2CA-36A-00-00-0 refers to the full distribution of flux, forward voltage, and color within a 2700K 5-step ANSI standard chromaticity region with a minimum of 80CRI, 2x12 die configuration, 10.6w power, 35.5V typical forward voltage.
- Bridgelux maintains a tolerance of  $\pm 0.1V$  on forward voltage measurements. Voltage minimum and maximum values at the nominal drive current are guaranteed by 100% test.
- Products tested under pulsed condition (10ms pulse width) at nominal drive current where  $T_{sp} = 25^{\circ}C$ .
- Thermal resistance value was calculated using total electrical input power; optical power was not subtracted from input power.

# Absolute Maximum Ratings

**Table 5:** Maximum Ratings

Parameter	Maximum Rating
LED Junction Temperature ( $T_j$ )	125°C
Storage Temperature	-40°C to +105°C
Operating Solder Point Temperature ( $T_{sp}$ )	-40°C to +105°C
Soldering Temperature	260°C or lower for a maximum of 10 seconds
Maximum Drive Current <sup>1</sup>	400mA
Maximum Peak Pulsed Forward Current <sup>2</sup>	600mA
Maximum Reverse Voltage	Bridgelux LEDs are not designed to be driven in reverse bias
Moisture Sensitivity Rating	MSL 3
Electrostatic Discharge	2kV HBM. JEDEC-JS-001-HBM and JEDEC-JS-001-2012

Notes for Table 5:

1. The condition of the maximum drive current is limited. Figure 7 can be reference.
2. Bridgelux recommends a maximum duty cycle of 10% and pulse width of 10 ms when operating LED SMD at maximum peak pulsed current specified. Maximum peak pulsed current indicate values where LED SMD can be driven without catastrophic failures.

# Product Bin Definitions

Table 6 lists the standard photometric luminous flux bins for Bridgelux SMD 7070 LEDs. Although several bins are listed, product availability in a particular bin varies by production run and by product performance. Not all bins are available in all CCTs.

**Table 6:** Luminous Flux Bin Definitions at 300mA,  $T_{sp}=25^{\circ}\text{C}$

Bin Code	Minimum	Maximum	Unit	Condition
B7	935	1010	lm	$I_F=300\text{mA}$
B8	1010	1090		
B9	1090	1175		
C1	1175	1270		
C2	1270	1370		
C3	1370	1480		
C4	1480	1600		
C5	1600	1730		
C6	1730	1870		

Note for Table 6:

1. Bridgelux maintains a tolerance of  $\pm 7.5\%$  on luminous flux measurements.

**Table 7:** Forward Voltage Bin Definition at 300mA,  $T_{sp}=25^{\circ}\text{C}$

Bin Code	Minimum	Maximum	Unit	Condition
MD	33.5	35	V	$I_F=300\text{mA}$
ME	35	36.5		
MF	36.5	38		
MG	38	39.5		
MH	39.5	41		

Note for Table 7:

1. Bridgelux maintains a tolerance of  $\pm 0.1\text{V}$  on forward voltage measurements.

# Product Bin Definitions

**Table 8:** 3- and 5-step MacAdam Ellipse Color Bin Definitions

CCT	Color Space	Center Point		Major Axis	Minor Axis	Ellipse Rotation Angle	Color Bin
		X	Y				
2700K	3 SDCM	0.4578	0.4101	0.00810	0.00420	53.70	3
	5 SDCM	0.4578	0.4101	0.01350	0.00700	53.70	5
3000K	3 SDCM	0.4338	0.4030	0.00834	0.00408	53.22	3
	5 SDCM	0.4338	0.4030	0.01390	0.00680	53.22	5
3500K	3 SDCM	0.4103	0.3961	0.00927	0.00414	54.00	3
	5 SDCM	0.4103	0.3961	0.01545	0.00690	54.00	5
4000K	3 SDCM	0.3818	0.3797	0.00939	0.00402	53.72	3
	5 SDCM	0.3818	0.3797	0.01565	0.00670	53.72	5
4500K	3 SDCM	0.3611	0.3658	0.00756	0.00338	57.58	3
	5 SDCM	0.3611	0.3658	0.01260	0.00563	57.58	5
5000K	3 SDCM	0.3447	0.3553	0.00822	0.00354	59.62	3
	5 SDCM	0.3447	0.3553	0.01370	0.00590	59.62	5
5700K	3 SDCM	0.3287	0.3417	0.00746	0.00320	59.09	3
	5 SDCM	0.3287	0.3417	0.01243	0.00533	59.09	5
6500K	3 SDCM	0.3123	0.3282	0.00669	0.00285	58.57	3
	5 SDCM	0.3123	0.3282	0.01115	0.00475	58.57	5

Notes for Table 8:

1. Color binning at  $T_{sp}=85^{\circ}\text{C}$
2. Bridgelux maintains a tolerance of  $\pm 0.007$  on x and y color coordinates in the CIE 1931 color space.

# Product Bin Definitions

Figure 1: C.I.E. 1931 Chromaticity Diagram (3 Color Bin Structure, hot-color targeted at  $T_{sp} = 85^{\circ}\text{C}$ )

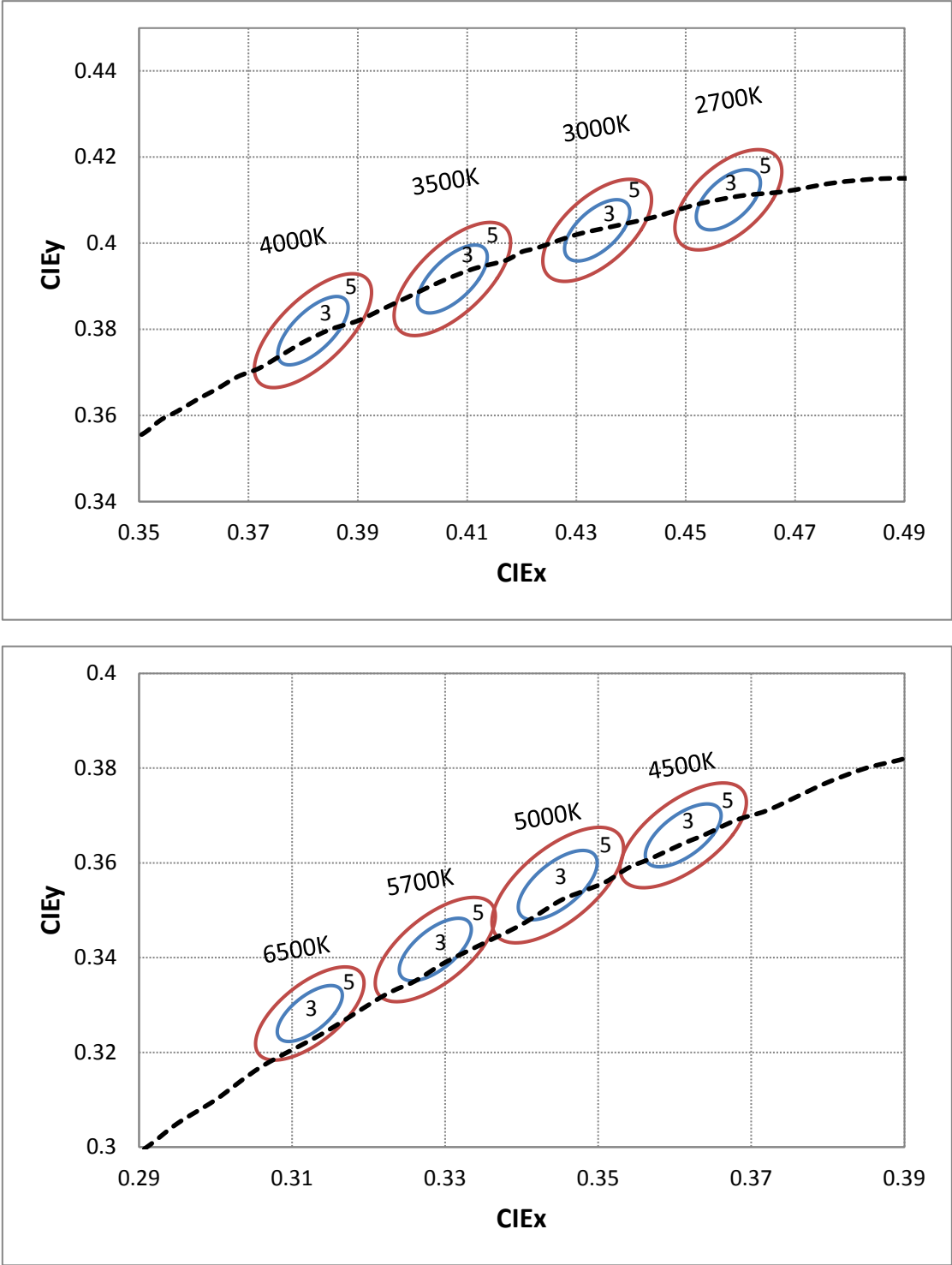

# Performance Curves

Figure 2: Drive Current vs. Voltage ( $T_{sp}=25^{\circ}\text{C}$ )

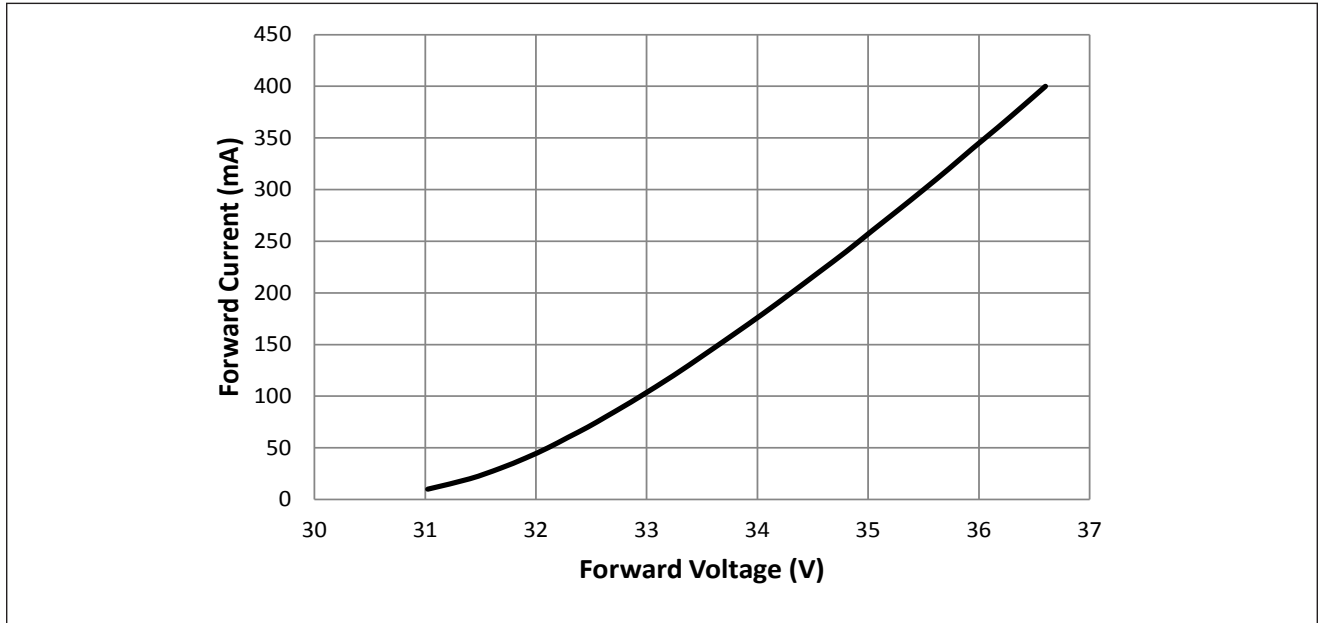
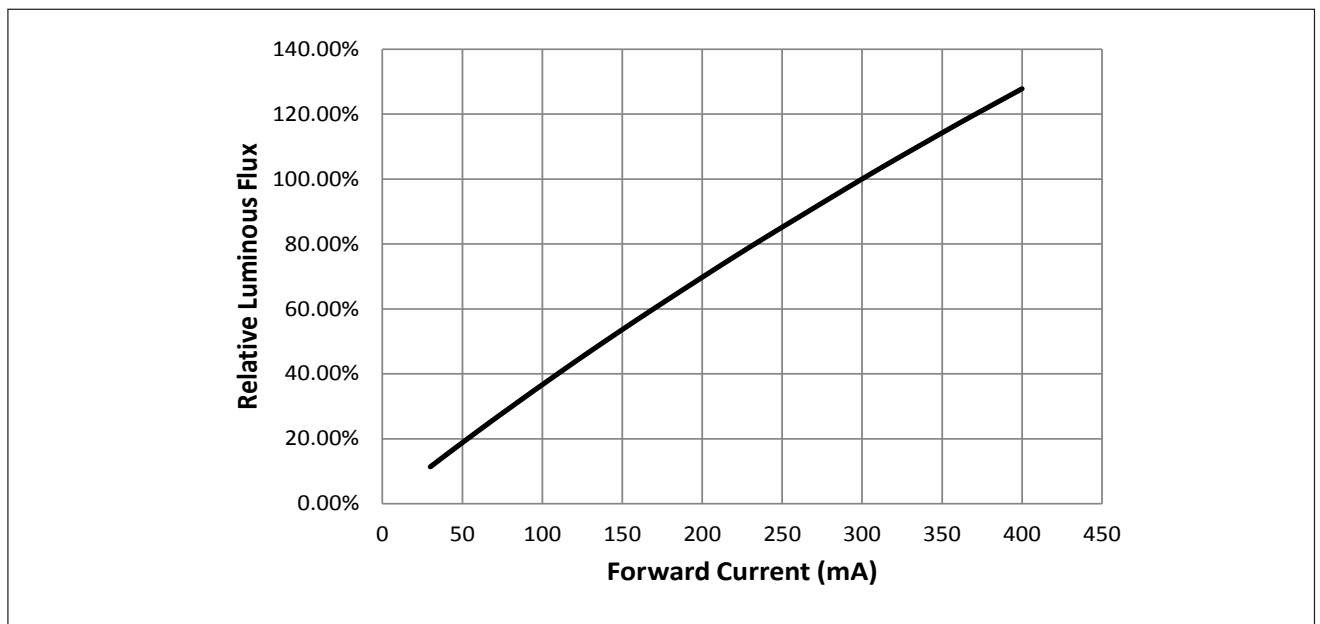

Figure 3: Typical Relative Luminous Flux vs. Drive Current ( $T_{sp}=25^{\circ}\text{C}$ )



Note for Figure 3:

1. Bridgelux does not recommend driving high power LEDs at low currents. Doing so may produce unpredictable results. Pulse width modulation (PWM) is recommended for dimming effects.

# Performance Curves

Figure 4: Typical Relative DC Flux vs. Solder Point Temperature

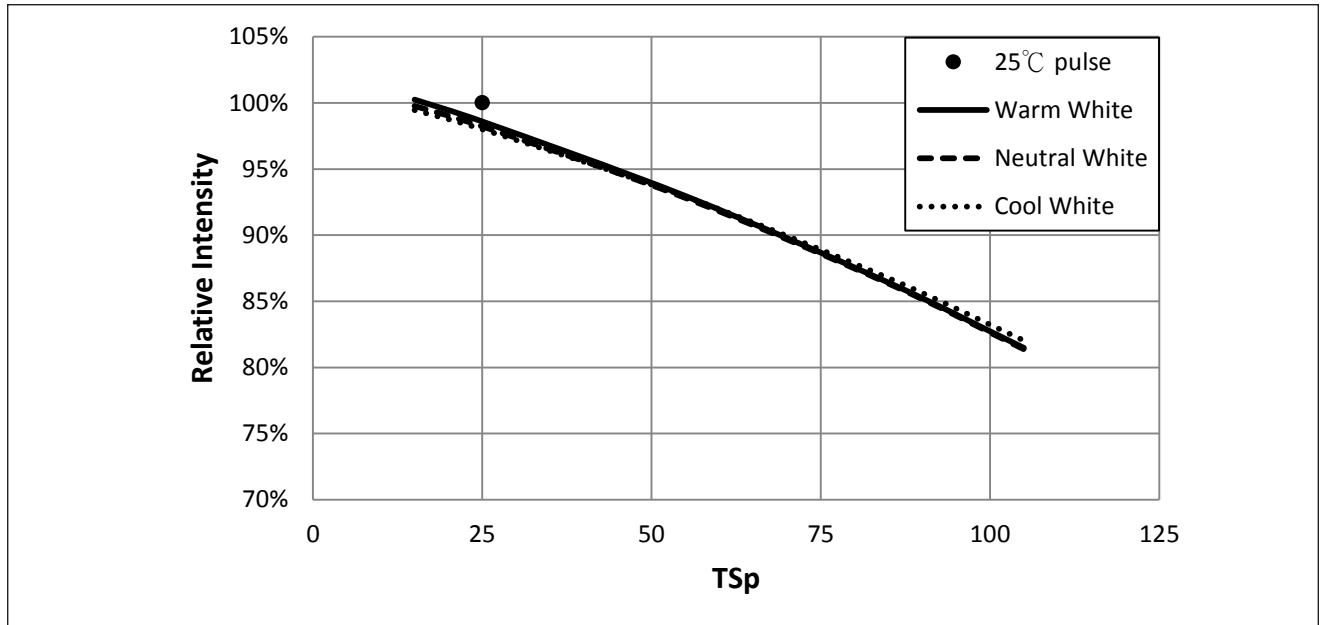
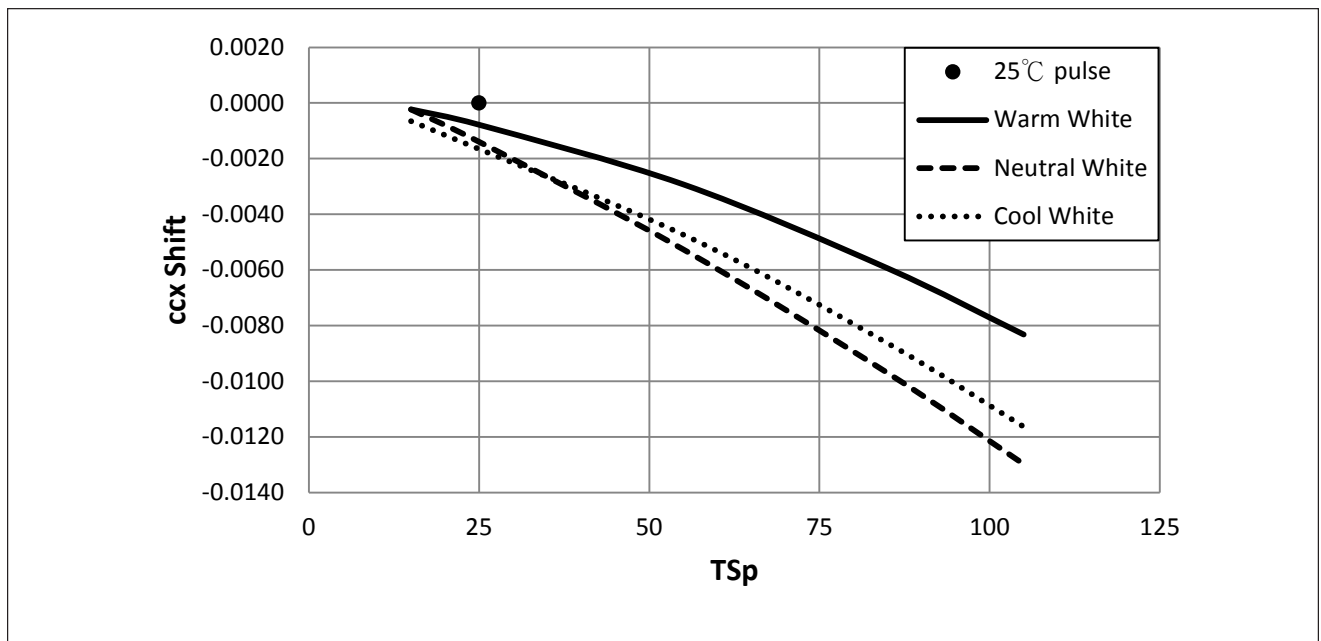

Figure 5: Typical DC ccx Shift vs. Solder Point Temperature



Notes for Figures 4 & 5:

1. Characteristics shown for warm white based on 2700K and 80 CRI.
2. Characteristics shown for neutral white based on 4000K and 80 CRI.
3. Characteristics shown for cool white based on 6500K and 80 CRI.
4. For other color SKUs, the shift in color will vary. Please contact your Bridgelux Sales Representative for more information.



# Performance Curves

**Figure 6: Typical DC ccy Shift vs. Solder Point Temperature**

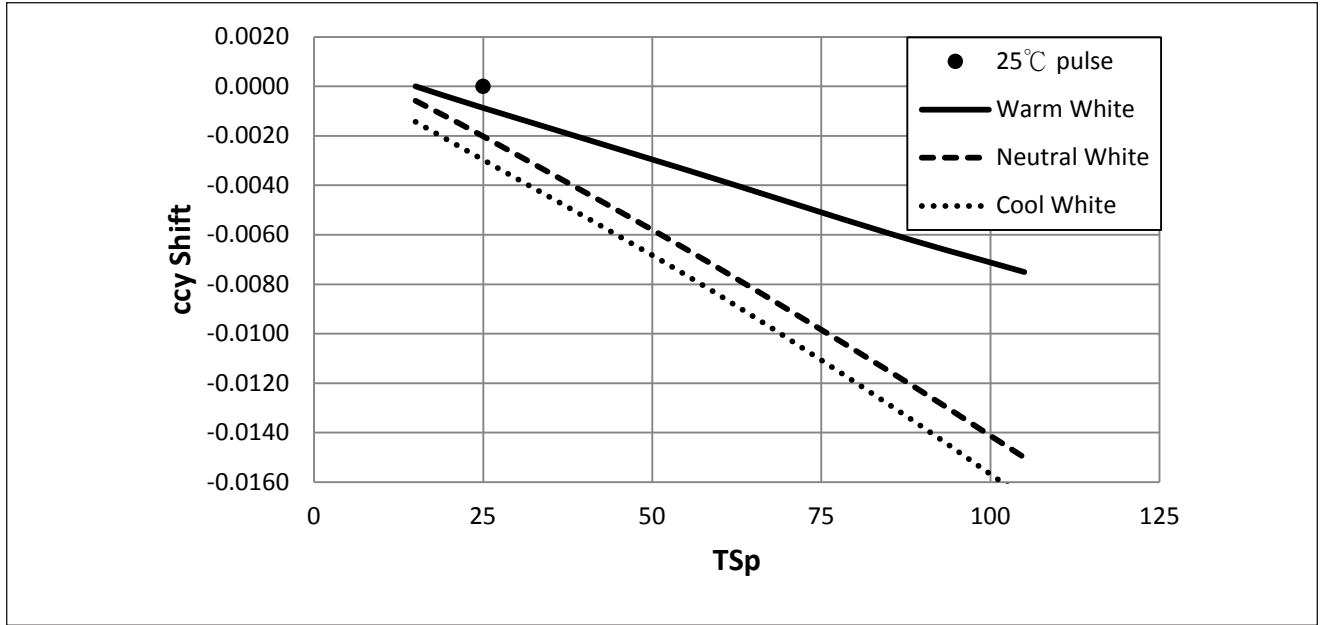

Notes for Figure 6:

1. Characteristics shown for warm white based on 2700K and 80 CRI.
2. Characteristics shown for neutral white based on 4000K and 80 CRI.
3. Characteristics shown for cool white based on 6500K and 80 CRI.
4. For other color SKUs, the shift in color will vary. Please contact your Bridgelux Sales Representative for more information.

**Figure 7: Drive Current Derating Curve**

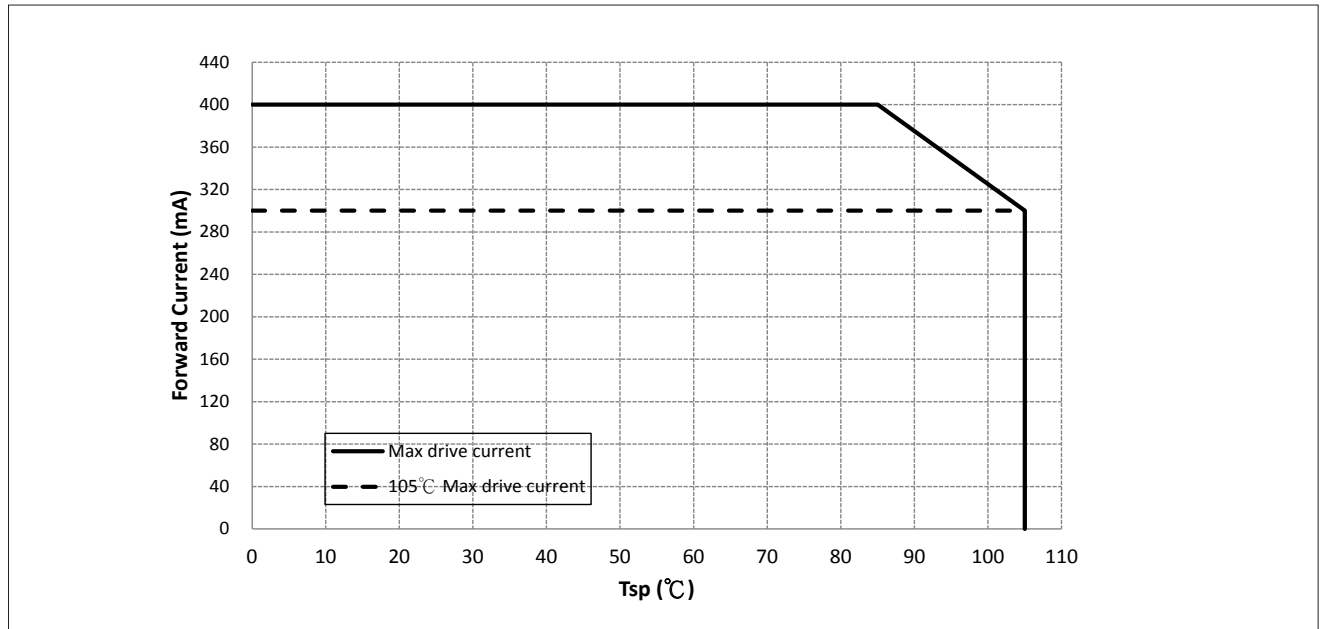

# Typical Radiation Pattern

Figure 8: Typical Spatial Radiation Pattern at 300mA,  $T_{sp} = 25^{\circ}\text{C}$

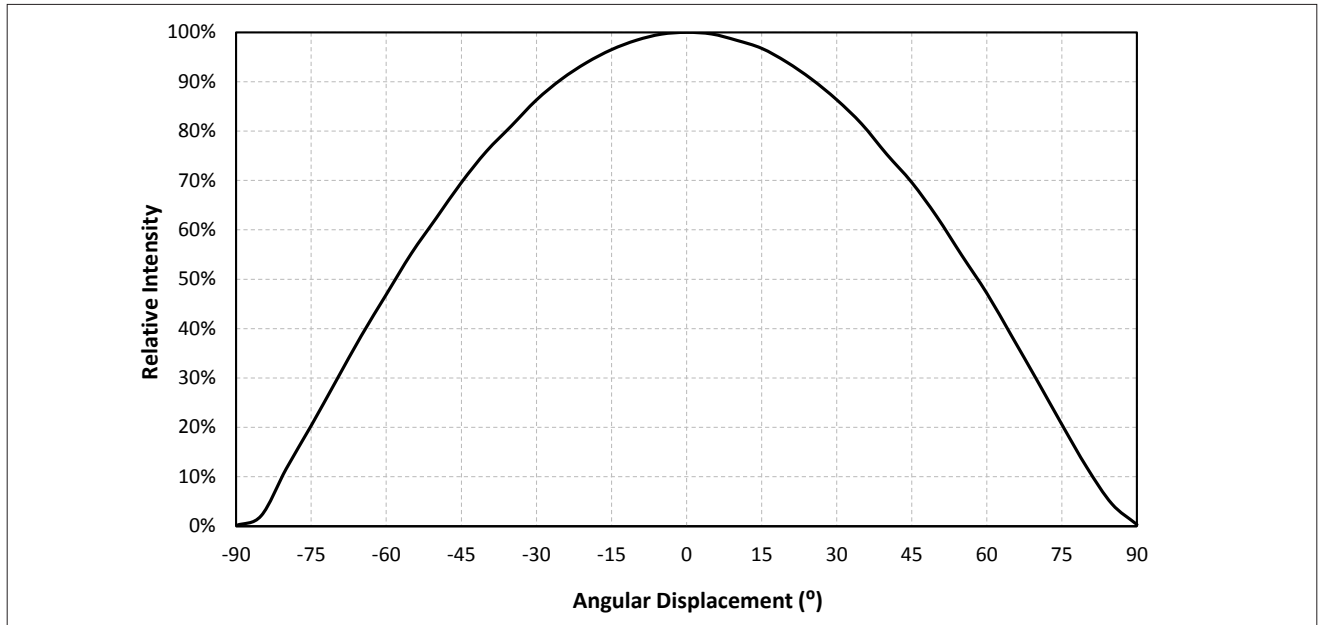

Notes for Figure 8:

1. Typical viewing angle is  $116^{\circ}$ .
2. The viewing angle is defined as the off axis angle from the centerline where luminous intensity (lv) is  $\frac{1}{2}$  of the peak value.

Figure 9: Typical Polar Radiation Pattern at 300mA,  $T_{sp} = 25^{\circ}\text{C}$

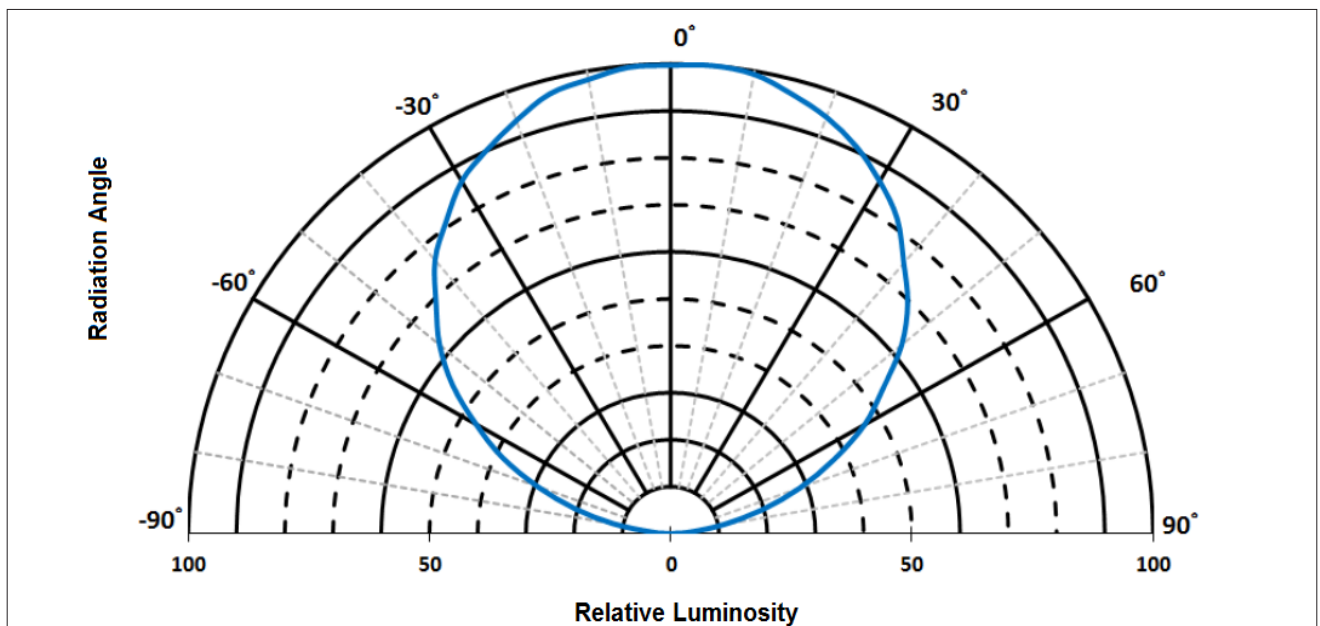

# Typical Color Spectrum

Figure 10: Typical Color Spectrum

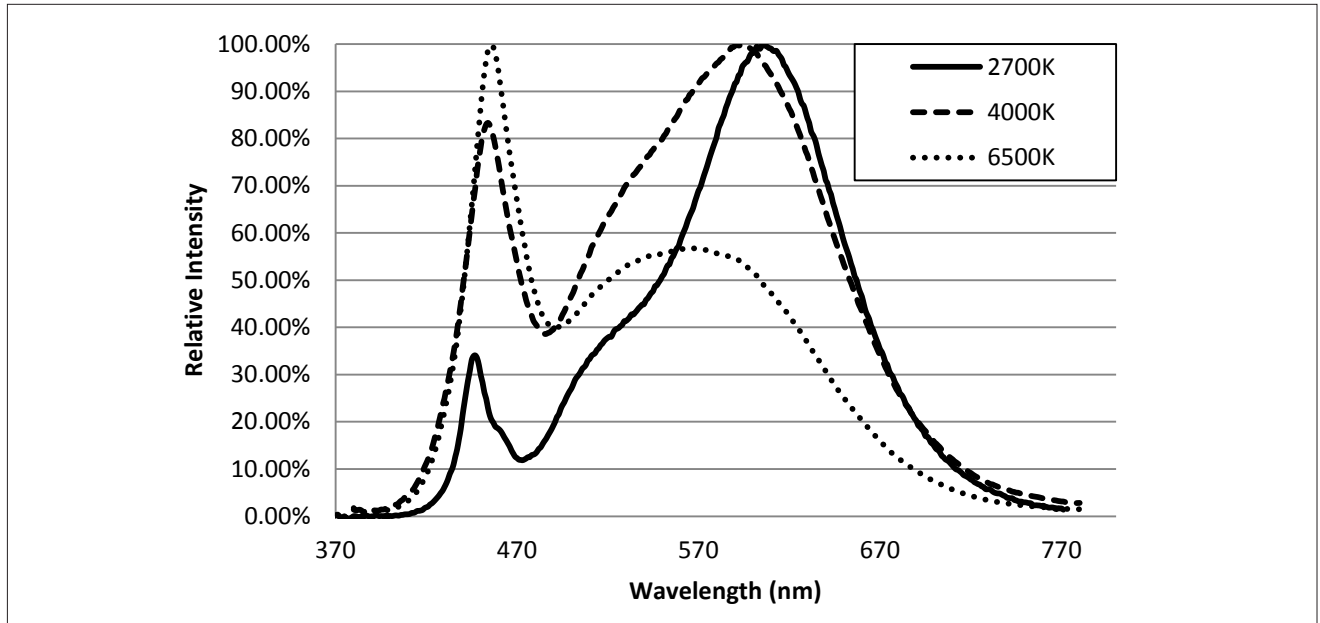

Notes for Figure 10:

1. Color spectra measured at nominal current for  $T_{sp} = 25^{\circ}\text{C}$
2. Color spectra shown for warm white is 2700K and 80 CRI.
3. Color spectra shown for neutral white is 4000K and 80 CRI.
4. Color spectra shown for cool white is 6500K and 80 CRI.

# Mechanical Dimensions

Figure 11: Drawing for SMD 7070

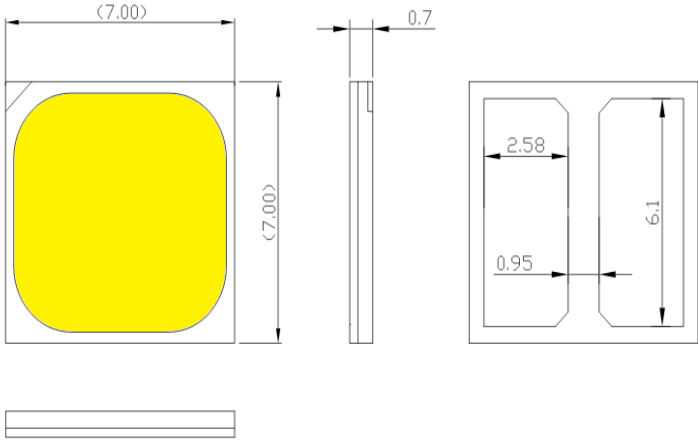

Notes for Figure 11:

- 1. Drawings are not to scale.
- 2. Drawing dimensions are in millimeters.
- 3. Unless otherwise specified, tolerances are  $\pm 0.10\text{mm}$ .

## Recommended PCB Soldering Pad Pattern

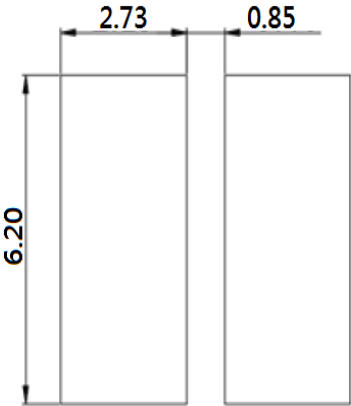

# Reliability

**Table 9: Reliability Test Items and Conditions**

No .	Items	Reference Standard	Test Conditions	Drive Current	Test Duration	Units Failed/Tested
1	Moisture/Reflow Sensitivity	J-STD-020E	$T_{sld} = 260^{\circ}\text{C}$ , 10sec, Precondition: $60^{\circ}\text{C}$ , 60%RH, 168hr	-	3 reflows	0/22
2	Low Temperature Storage	JESD22-A119	$T_a = -40^{\circ}\text{C}$	-	1000 hours	0/22
3	High Temperature Storage	JESD22-A103D	$T_a = 105^{\circ}\text{C}$	-	1000 hours	0/22
4	Low Temperature Operating Life	JESD22-A108D	$T_a = -40^{\circ}\text{C}$	300mA	1000 hours	0/22
5	Temperature Humidity Operating Life	JESD22-A101C	$T_{sp} = 85^{\circ}\text{C}$ , RH=85%	300mA	1000 hours	0/22
6	High Temperature Operating Life	JESD22-A108D	$T_{sp} = 105^{\circ}\text{C}$	300mA	1000 hours	0/22
7	Power switching	IEC62717:2014	$T_{sp} = 105^{\circ}\text{C}$ 30 sec on, 30 sec off	300mA	30000 cycles	0/22
8	Thermal Shock	JESD22-A106B	$T_a = -40^{\circ}\text{C} \sim 100^{\circ}\text{C}$ ; Dwell : 15min; Transfer: 10sec	-	200 cycles	0/22
9	Temperature Cycle	JESD22-A104E	$T_a = -40^{\circ}\text{C} \sim 100^{\circ}\text{C}$ ; Dwell at extreme temperature: 15min; Ramp rate < $105^{\circ}\text{C}/\text{min}$	-	200 cycles	0/22
10	Electrostatic Discharge	JS-001-2012	HBM, 2kV, 15k $\Omega$ , 100pF, Alternately positive or negative	-	-	0/22

## Passing Criteria

Item	Symbol	Test Condition	Passing Criteria
Forward Voltage	Vf	300mA	$\Delta Vf < 10\%$
Luminous Flux	Fv	300mA	$\Delta Fv < 30\%$
Chromaticity Coordinates	(x, y)	300mA	$\Delta u'v' < 0.007$

Notes for Table 9:

1. Measurements are performed after allowing the LEDs to return to room temperature
2.  $T_{sld}$  : reflow soldering temperature;  $T_a$  : ambient temperature

# Reflowing Characteristics

Figure 12 : Reflow Profile

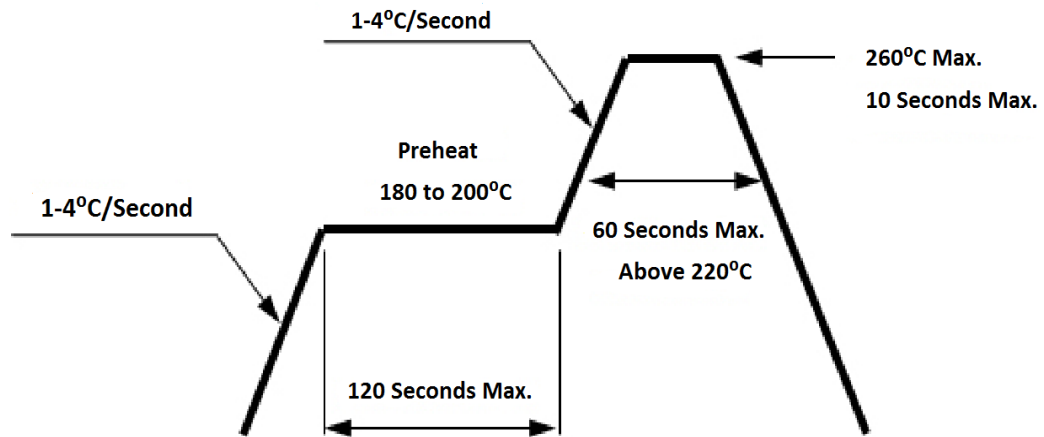

Profile Feature	Lead Free Assembly
Preheat: Temperature Range	180°C – 200°C
Preheat: Time (Maximum)	120 seconds
Peak Temperature	260°C
Soldering Time (Maximum)	10 seconds
Allowable Reflow Cycles	2

Figure 13 : Pick and Place

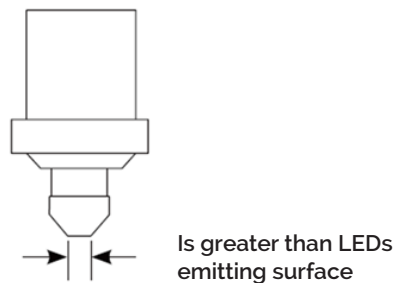

Note for Figure 13:

- When using a pick and place machine, choose a nozzle that has a larger diameter than the LED's emitting surface. Using a Pick-and-Place nozzle with a smaller diameter than the size of the LEDs emitting surface will cause damage and may also cause the LED to not illuminate.

# Packaging

**Figure 14: Emitter Reel Drawings**

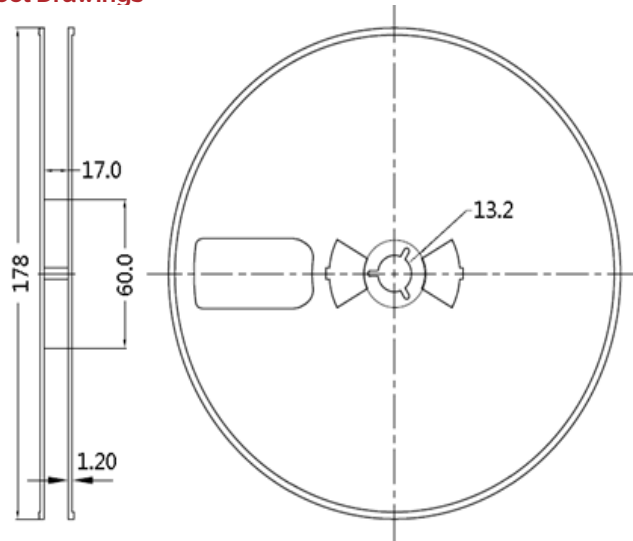

Note for Figure 14:

1. Drawings are not to scale. Drawing dimensions are in millimeters.

**Figure 15: Emitter Tape Drawings**

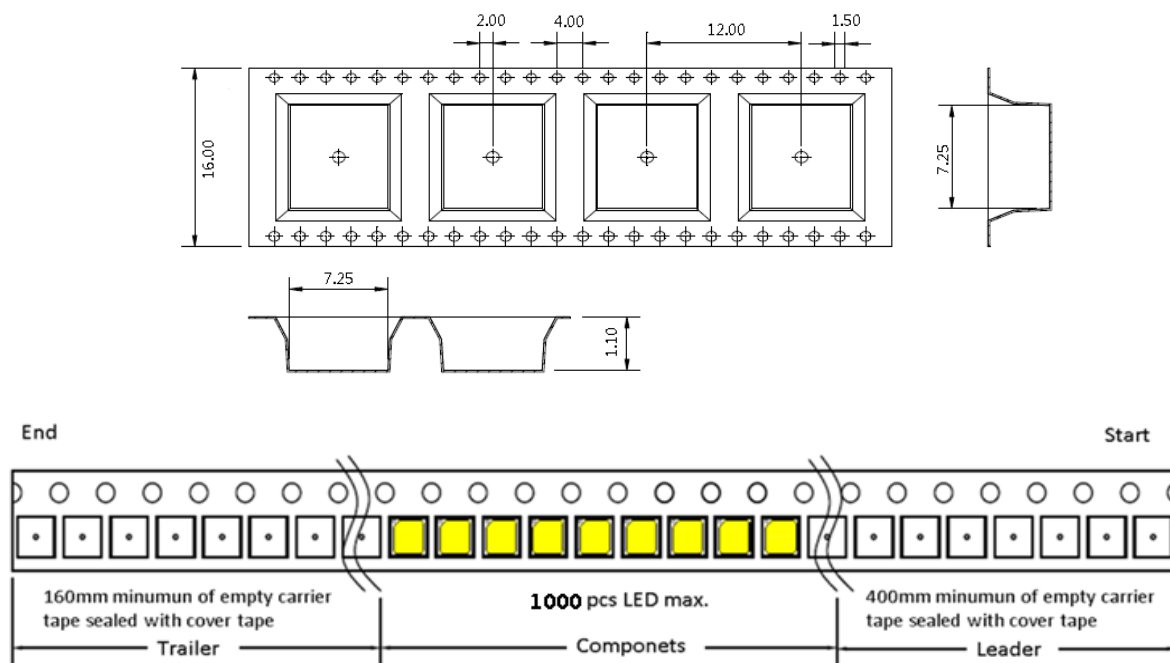

Note for Figure 15:

1. Drawings are not to scale. Drawing dimensions are in millimeters.

# Packaging

**Figure 16: Emitter Reel Packaging Drawings**

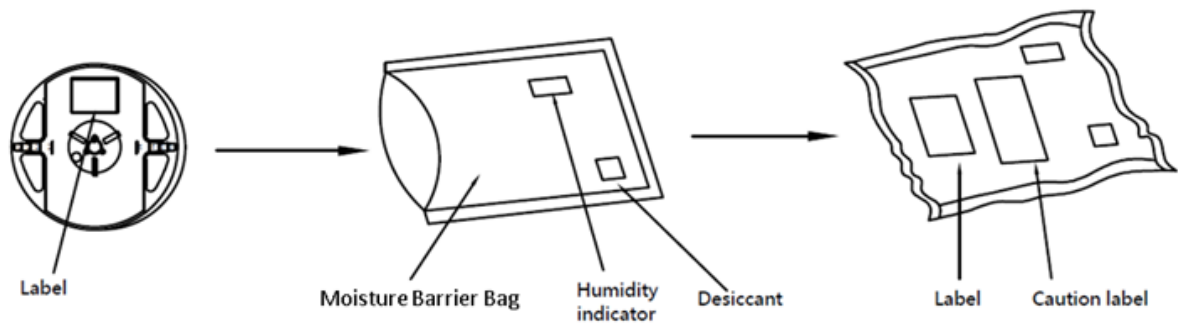

Note for Figure 16:  
1. Drawings are not to scale.



# Design Resources

Please contact your Bridgelux sales representative for assistance.

## Precautions

### **CAUTION: CHEMICAL EXPOSURE HAZARD**

Exposure to some chemicals commonly used in luminaire manufacturing and assembly can cause damage to the LED emitter. Please consult Bridgelux Application Note AN51 for additional information.

### **CAUTION: EYE SAFETY**

This SMD package emits visible light, that, under certain circumstances, could be harmful to the eye. Proper safeguards must be used.

### **CAUTION: RISK OF BURN**

Do not touch the SMD LED emitter during operation. Allow the emitter to cool for a sufficient period of time before handling. The SMD LED emitter may reach elevated temperatures such that could burn skin when touched.

## CAUTION

### **CONTACT WITH LIGHT EMITTING SURFACE (LES)**

Avoid any contact with the LES. Do not touch the LES of the emitter or apply stress to the LES (yellow phosphor resin area). Contact may cause damage to the emitter

Optics and reflectors must not be mounted in contact with the LES (yellow phosphor resin area).

## Disclaimers

### **MINOR PRODUCT CHANGE POLICY**

The rigorous qualification testing on products offered by Bridgelux provides performance assurance. Slight cosmetic changes that do not affect form, fit, or function may occur as Bridgelux continues product optimization.

### **STANDARD TEST CONDITIONS**

Unless otherwise stated, LED emitter testing is performed at the nominal drive current.

# About Bridgelux: Bridging Light and Life™

At Bridgelux, we help companies, industries and people experience the power and possibility of light. Since 2002, we've designed LED solutions that are high performing, energy efficient, cost effective and easy to integrate. Our focus is on light's impact on human behavior, delivering products that create better environments, experiences and returns—both experiential and financial. And our patented technology drives new platforms for commercial and industrial luminaires.

**For more information about the company, please visit**  
**bridgelux.com**  
**twitter.com/Bridgelux**  
**facebook.com/Bridgelux**  
**youtube.com/user/Bridgelux**  
**linkedin.com/company/bridgelux-inc-\_2**  
**WeChat ID: BridgeluxInChina**



46430 Fremont Boulevard  
Fremont, CA 94538 U.S.A.  
Tel (925) 583-8400  
**www.bridgelux.com**

© 2018 Bridgelux, Inc. All rights reserved 2018. Product specifications are subject to change without notice. Bridgelux and the Bridgelux stylized logo design are registered trademarks of Bridgelux, Inc. All other trademarks are the property of their respective owners.