

| REV. | DATE | D.C.N. NUMBER | DESCRIPTION | CHECKED BY DATE | APPROVED BY DATE |
|------|----------|---------------|-------------|-----------------|------------------|
| 1 | 22/09/11 | | FIRST ISSUE | MH 22/09/11 | PW 22/09/11 |

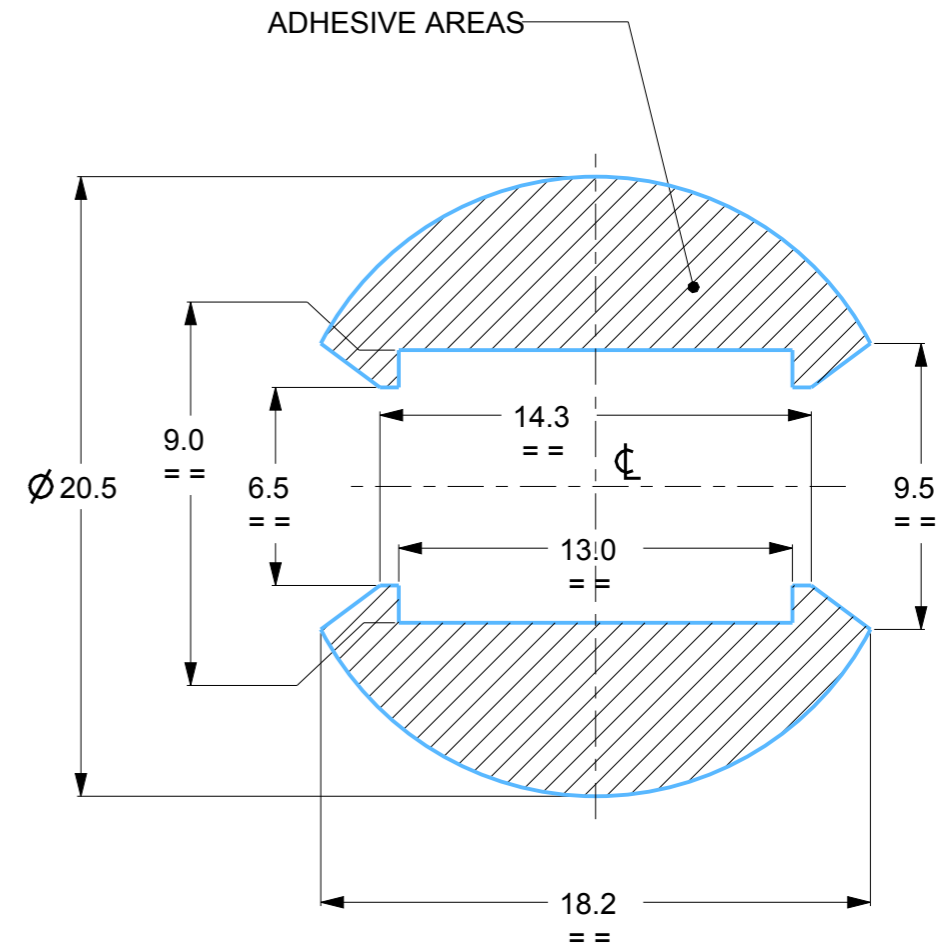
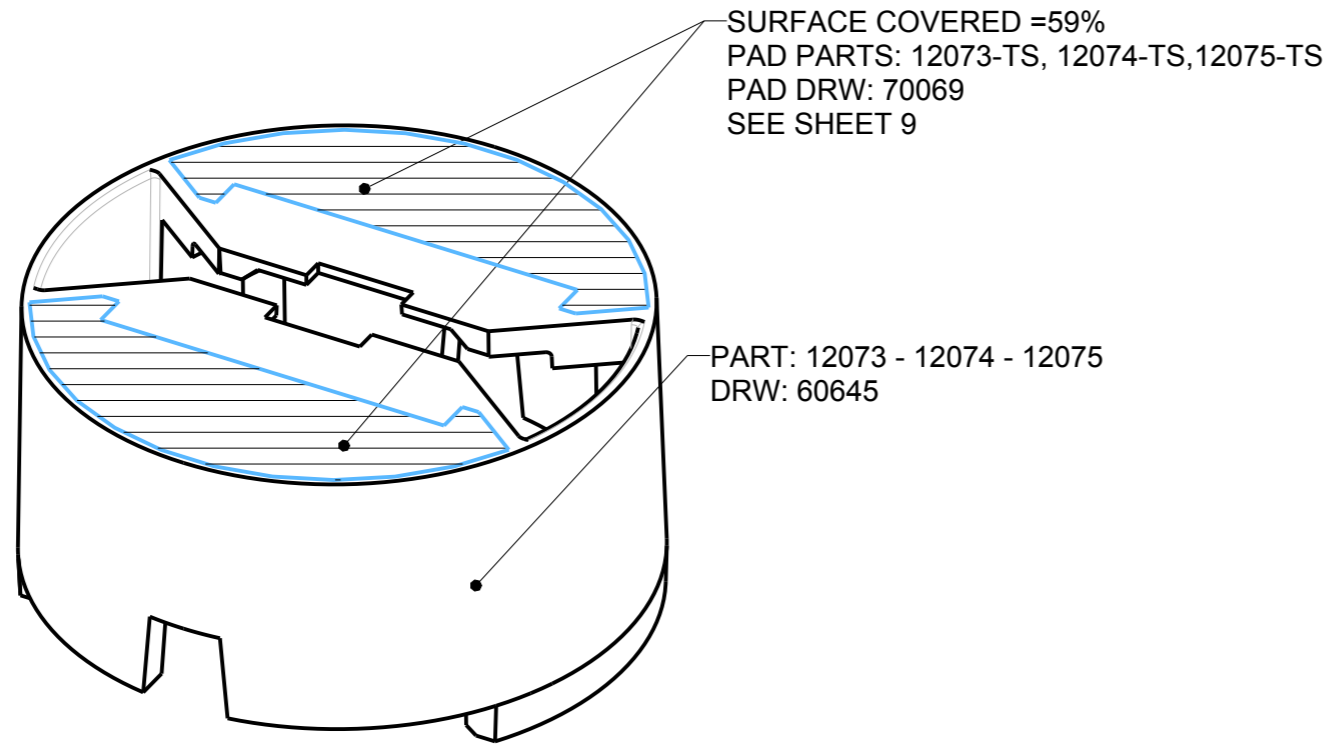

NOTES:
 -TAPE SPEC: 3M 9495LE
 -THICKNESS 0.17mm
 -GENERAL OFFSET FROM HOLDER EDGES IS 0.2mm

| PART NUMBER | COLOUR |
|-------------|--------|
| 12073-TS | BLACK |
| 12074-TS | WHITE |
| 12075-TS | CLEAR |

SCALE 4:1

Sheet 9 of 10

| | | | | | |
|--|--|--|------------------|-----------|-------------|
| 103 BUCKINGHAM AVE, SLOUGH, BERKSHIRE, SL1 4PF, UK Tel: +44 1753 610800, Fax: +44 1753 611359 Email: design@carclo-optics.com www.carclo-optics.com | Title | 20mm DIA LED TAPED OPTIC HOLDER FOR CREE XP-E & STD OPTICS | | | |
| | Customer | CARCLO | | | |
| Drawn by | FP | Material | SEE NOTE | Scale | AS SPEC. |
| THIRD ANGLE PROJECTION | GENERAL TOLERANCES UNLESS OTHERWISE STATED | | DIMENSIONS IN mm | | Format Size |
| | LINEAR | ANGULAR | | | A3 |
| | 0 ± 0.25 | 0 ± 1° | | | |
| | 0.0 ± 0.1 | 0.0 ± 0.5° | | | |
| | 0.00 ± 0.05 | 0.00 ± 0.1° | | | |
| | CARCLO technical plastics | | | | |
| | CONFIDENTIAL: UNAUTHORISED COPYING, DISCUSSION & DISTRIBUTION PROHIBITED | | | | |
| | CAD File | 80-12567-70064-UNI-SHEET-PAD | | | |
| | Drw. N° | 70069 | Part N° | SEE TABLE | |

GENERAL LAYOUT INFO

| REV. | DATE | D.C.N. NUMBER | DESCRIPTION | CHECKED BY DATE | APPROVED BY DATE |
|------|----------|---------------|-------------|-----------------|------------------|
| 1 | 22/09/11 | | FIRST ISSUE | MH 22/09/11 | PW 22/09/11 |

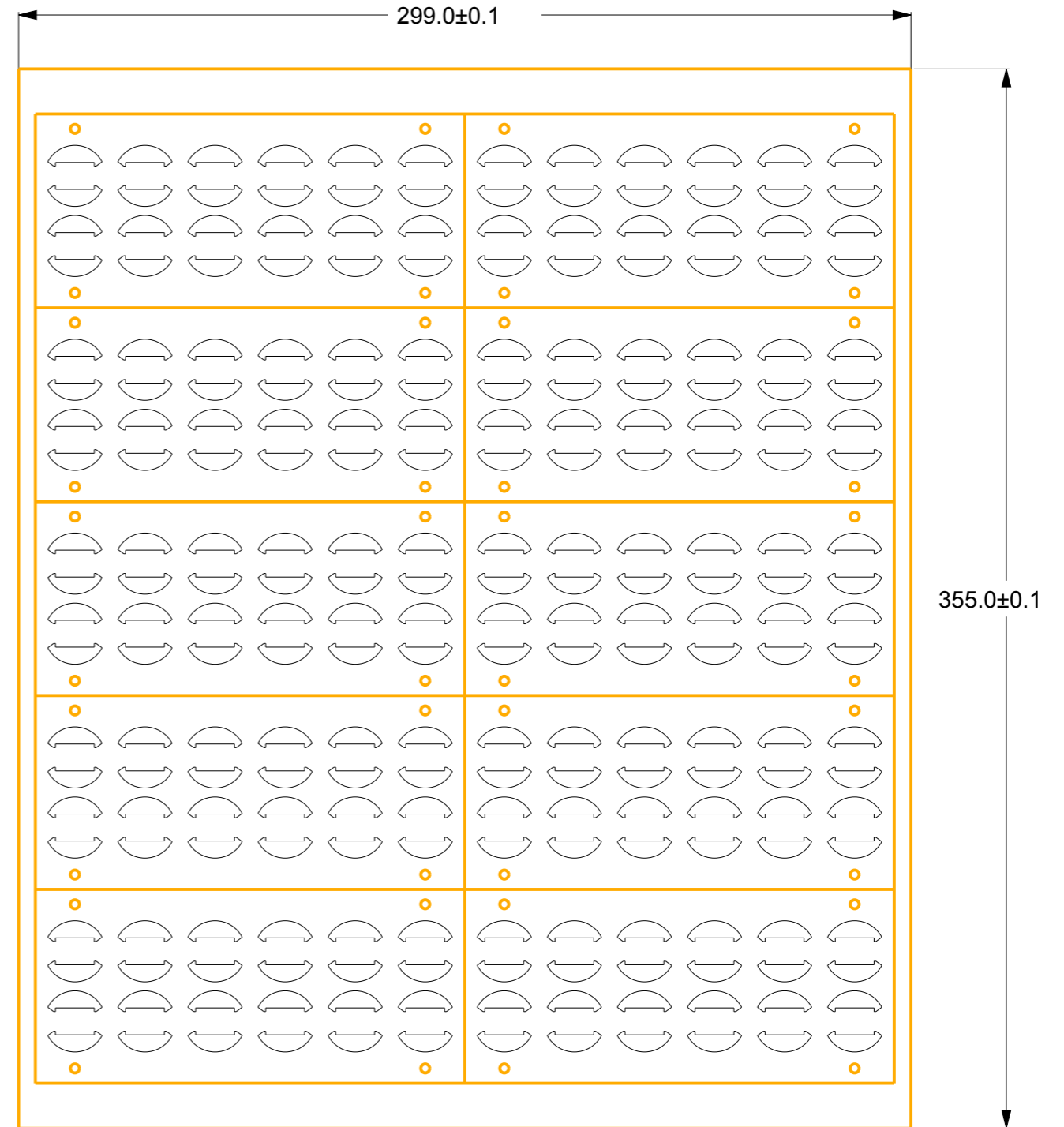
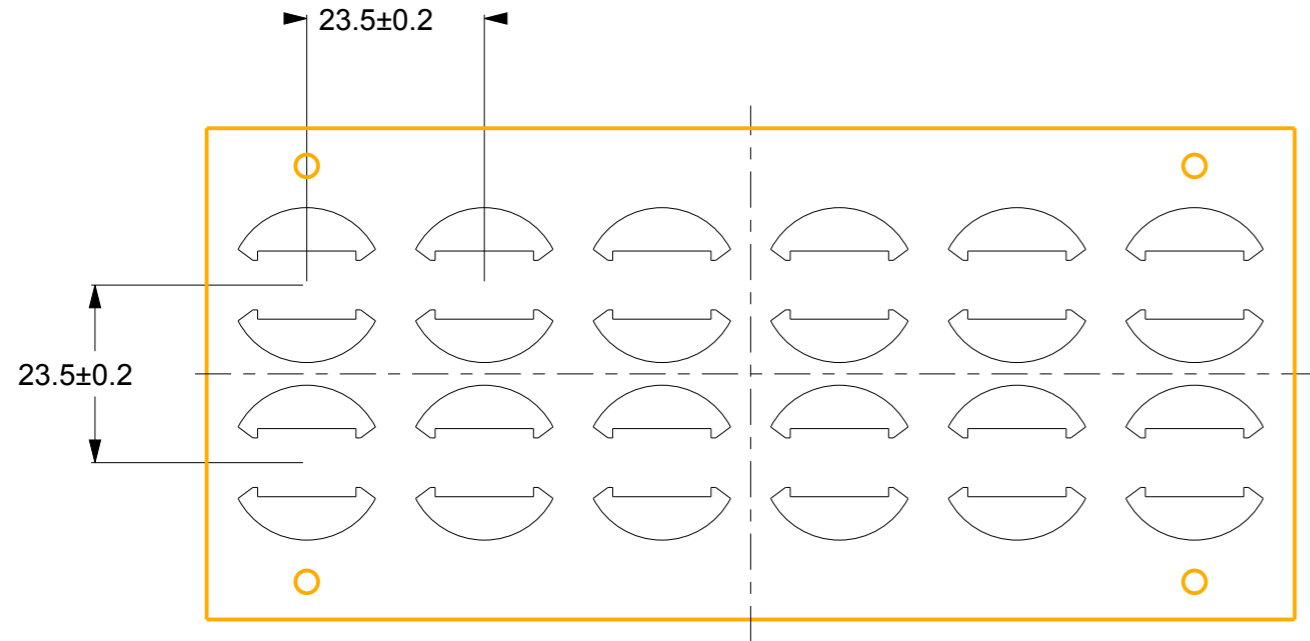

- NOTES:
- TAPE SPEC: 3M 9495LE
 - THICKNESS 0.17mm
 - GENERAL OFFSET FROM HOLDER EDGES IS 0.2mm

SCALE 1:2

| | | | | | | |
|--|--|-------------------------------------|---------------------------------------|----------|------------------------------|----------|
| <p>103 BUCKINGHAM AVE, SLOUGH, BERKSHIRE, SL1 4PF, UK Tel: +44 1753 610800. Fax: +44 1753 611359 Email: design@carclo-optics.com www.carclo-optics.com</p> | Title | | UNIVERSAL SHEET ADHESIVE PAD ASSEMBLY | | | |
| | Customer | | CARCLO | | | |
| Drawn by | | FP | Material | SEE NOTE | Scale | AS SPEC. |
| THIRD ANGLE PROJECTION | GENERAL TOLERANCES UNLESS OTHERWISE STATED | | DIMENSIONS IN mm | | Format Size | A3 |
| | LINEAR | ANGULAR | CAD File | | 80-12567-70064-UNI-SHEET-PAD | |
| | 0 ± 0.25 0.0 ± 0.1 0.00 ± 0.05 | 0 ± 1° 0.0 ± 0.5° 0.00 ± 0.1° | Drw. N° | | 70064 | |
| CARCLO technical plastics CONFIDENTIAL: UNAUTHORISED COPYING, DISCUSSION & DISTRIBUTION PROHIBITED | | | Part N° | | 12567 | |