

CUSTOMER DRAWING SHEET 2 ONLY

REV.	DATE	D.C.N. No	DESCRIPTION
1	13/01/12		FIRST ISSUE
2	21/06/12	06/12/1337	CHANGED SURFACE TEXTURE TO VDI 21-24 FROM VDI 30-33
2A	15/08/12	07/12/1342	ADDED SUBSTRATE TABLE & TIDIED UP DRAWING.
2B	18/01/16	1450 / 1458	TOLS UPDATED TO DIN16742:TG5. REDIMENSIONED FOR INSPECTION. ALT MTL ADDED. P.SUTTON

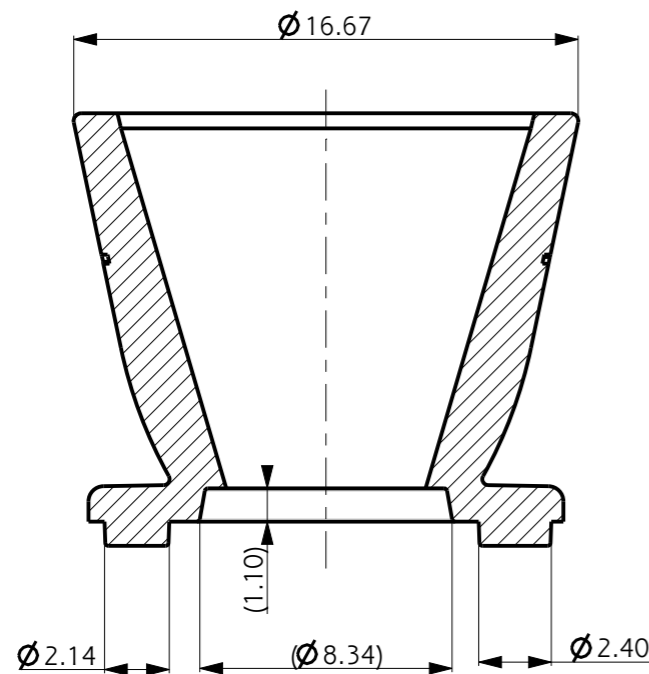

SCALE 1:1

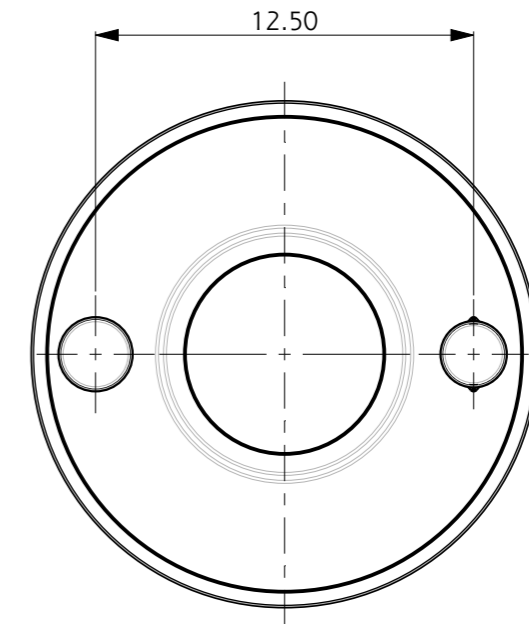
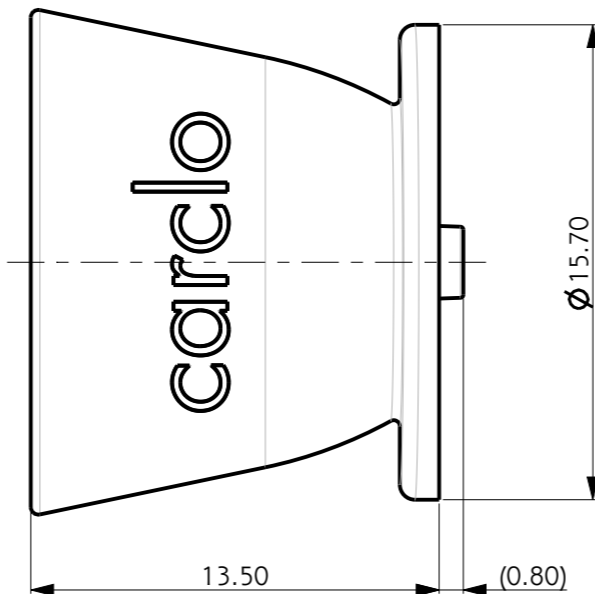
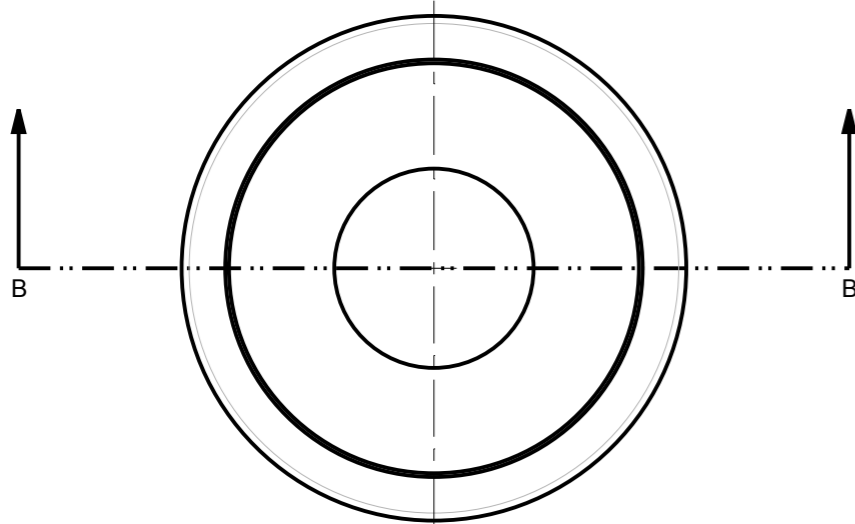

SECTION B-B

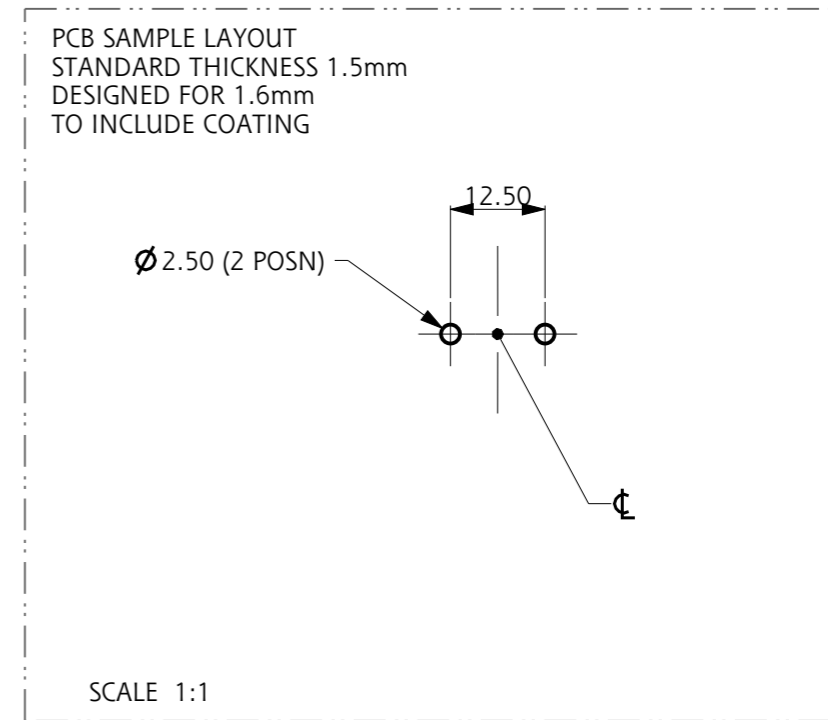

NOTES:

- 1 - MATERIAL: POLYCARBONATE
- 2 - FINISH: COMMERCIAL POLISH FOR ALL NON OPTICAL SURFACES
- 3 - OVERALL PART THICKNESS = 1.4mm
- 4 - COLOUR = CARCLO GREY / ALUMINIUM COATED
- 5 - GENERAL DRAFT 1°
- 6 - SIMPLIFIED GEOMETRY SHOWN. NOT SUITABLE FOR OPTICAL RAYTRACE

SCALE 4:1

Sheet 2 of 2

<p>technical plastics 103 BUCKINGHAM AVE, SLOUGH, BERKSHIRE, SL1 4PF, UK Tel: +44 1753 610800 Fax: +44 1753 811359 design@carclo-optics.com www.carclo-optics.com</p>	Title		ARCHIMEDES MEDIUM BEAM HIGHBAY REFLECTOR - GLUE			
	Customer		CARCLO			
Drawn by	FP	Material	SEE NOTE		Scale	AS SPEC.
THIRD ANGLE PROJECTION	GENERAL TOLERANCES UNLESS OTHERWISE STATED DIN16742:TG5		DIMENSIONS IN mm		Format Size	A3
	CONFIDENTIAL: UNAUTHORISED COPYING, DISCUSSION & DISTRIBUTION PROHIBITED		CAD File	12530-70029_REV-2B_REFL_60_GLUE		
	Drw. N°	70029	Part N°	12530		