

The high efficiency **Aurora** Converter provides up to 50W/10A output with industry standard “B” case (2” x 1”) package. The power stage is designed with the efficiently patented “Coupled-Inductor SR” topology, which results in very high efficiency. The low profile module design with silicone potted metal package eliminates the hot spots and further secures better thermal performance.

PART NUMBER SYSTEM

AB	48	050	a	b	c	d	-	10	XX	X
Series Name	Input Voltage	Output Voltage	Enable Logic	Pin Dimension	Standoff Height	Base-Plate		Output Current	Suffix	Version
AB	48=36V~75V 24=18V~36V	Unit: 0.1V Increments 120=12V 050=5V	P: Positive N: Negative	0 : 0.12" 1 : 0.16"	0 : 0.00"	E : Enclosed standard type	-	00~12 : For output current rating		For marketing purpose only

MODEL LIST (Contact to factory for special input / output)

Part Number *	Maximum Input	Maximum Output	Efficiency	Part Number *	Maximum Input	Maximum Output	Efficiency
AB48120abcd-04XXX	36V~75V 55W	12.0V/4.2A 50W	91%	AB24120abcd-04XXX	18V~36V 55W	12.0V/4.2A 50W	91%
AB48050abcd-10XXX	36V~75V 56W	5.0V/10A 50W	90%	AB24050abcd-10XXX	18V~36V 56W	5.0V/10A 50W	90%
AB48033abcd-12XXX	36V~75V 45W	3.3V/12A 40W	88%	AB24033abcd-12XXX	18V~36V 45W	3.3V/12A 40W	88%
AB48025abcd-12XXX	36V~75V 35W	2.5V/12A 30W	86%	AB24025abcd-12XXX	18V~36V 35W	2.5V/12A 30W	86%

REFERENCED THERMAL IMAGES

To be updated in next version	To be updated in next version
-------------------------------	-------------------------------

Aurora Converter

SPECIFICATIONS

Absolute Maximum Ratings		
Temperature	Operation Storage	-40°C to +110°C -55°C to +125°C
Input Voltage Range	Operation: 24V Models 48V Models Transient (100mS): 24V Models 48V Models	-0.5V to +40Vdc -0.5V to +80Vdc 50V Maximum 100V Maximum
Isolation Voltage	Input to Output Input to Case Output to Case	2.0KV Minimum 1.0KV Minimum 0.5KV Minimum
Remote Control		-0.5V to +12Vdc

General Parameters		
Conversion Efficiency	Typical	See table
Switching Frequency	Typical	400KHz
MTBF	Bellcore TR-332 issue 6	7.6×10 ⁶ hrs @GB/25°C (AB48050abcd-08)
OTP	Internal	110°C(Tc) ±5°C
Weight		35g

Control Functions		
Remote Control	Logic High Logic Low	+3.0V to +6.5V 0V to +1.0V
Input Current of Remote Control Pin		-0.5mA ~ +1.5mA

Input		
Operation Voltage Range	24V Models 48V Models	+18V to +36Vdc +36V to +75Vdc
Reflected Ripple Current	L _{EXT} = 10uH	20mA Max
Power ON Voltage Ranges	24V Models 48V Models	+17.0V to +18.0Vdc +34.0V to +36.0Vdc
Power OFF Voltage Ranges	24V Models 48V Models	+15.6V to +16.6Vdc +31.2V to +33.2Vdc
Off State Input Current	V _{NOM}	3mA Max
Latch-State Input Current	V _{NOM}	8mA Max
Input Capacitance	24V Models 48V Models	10.0uF Max 6uF Max

Output		
Voltage Accuracy	Typical	±1.0%
Line Regulation	Full Input Range	±0.2%
Load Regulation	0%~100%	±0.2%
Temperature Drift	-40°C ~100°C	±0.03%/°C
Output Tolerance Band	All Conditions	±4%
Ripple & Noise (20MHz)	Peak-Peak (RMS)	3% (1%) V _O
Over Voltage Protection	V _{NOM} , 10% Load	115~130 %V _O
Output Current Limits	V _{NOM}	108%~125%
Voltage Trim	V _{NOM} , 10% Load	±10%
Input Ripple Rejection (<1KHz)	V _{NOM} , Full Load	-50dB
Step Load (2.5A/μS)	50%~75% Load	±8%Vo /500μS
Start-Up Delay Time	V _{NOM} , Full Load	20mS/250mS

Aurora Converter

TYPICAL WAVES AND CURVES

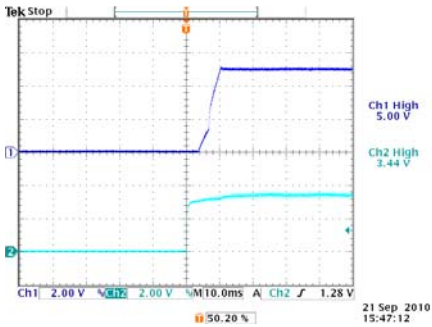

Start-up waveform of AB24050abcd-10XXX
(V_{IN} : 24V, Load: 10A)

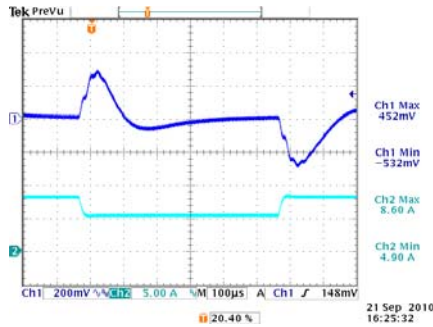

Transient response of AB24050abcd-10XXX
(V_{IN} : 24V, Load: 8.5A/5A@2.5A/ μ S)

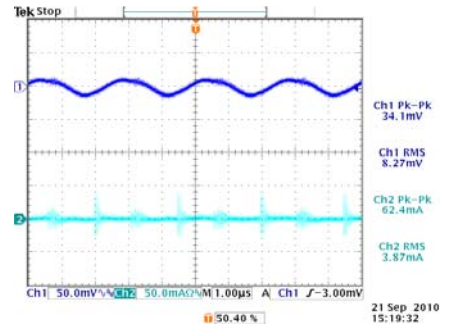

Input/Output ripples of AB24050abcd-10XXX
(V_{IN} : 24V, Load: 10A, L_{IN} =10uH)

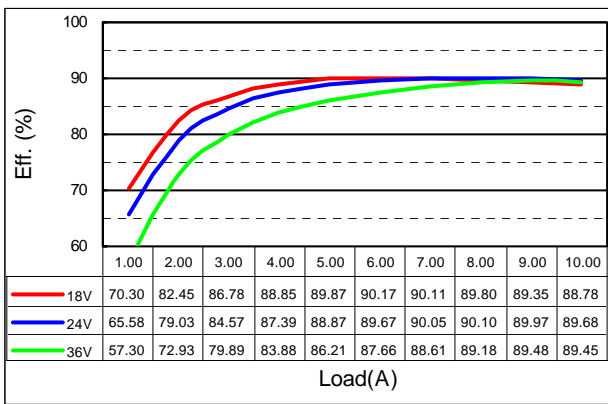

Efficiency Plot of AB24050abcd-10XXX

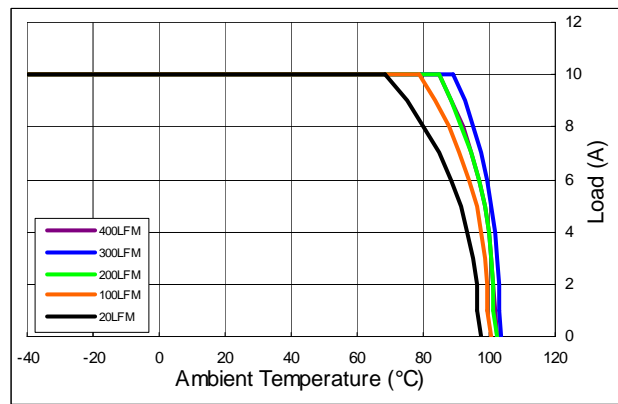

Derating Curves of AB24050abcd-10XXX for T_C = 110°C

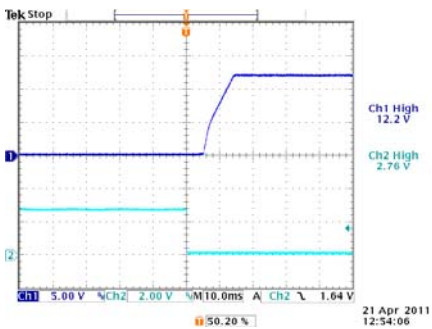

Start-up waveform of AB24120abcd-04XXX
(V_{IN} : 24V, Load: 4.2A)

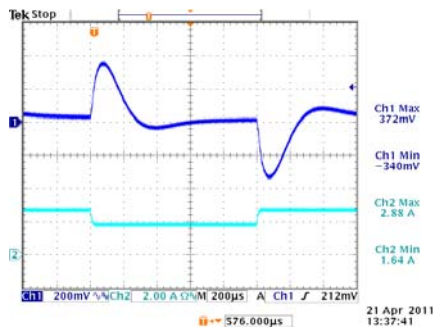

Transient response of AB24120abcd-04XXX
(V_{IN} : 24V, Load: 3A/2A@2.5A/ μ S)

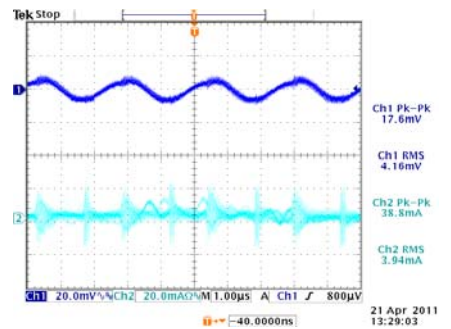

Input/Output ripples of AB24120abcd-04XXX
(V_{IN} : 24V, Load: 4.2A, L_{IN} =10uH)

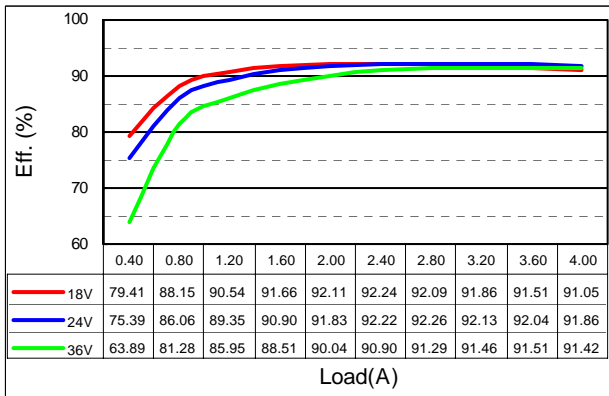

Efficiency plot of AB24120abcd-04XXX

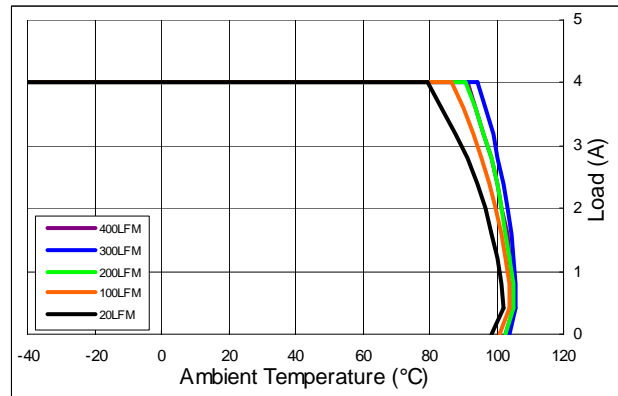

Derating curves of AB24120abcd-04XXX for T_C = 110°C

Aurora Converter

METAL ENCLOSED PACKAGE

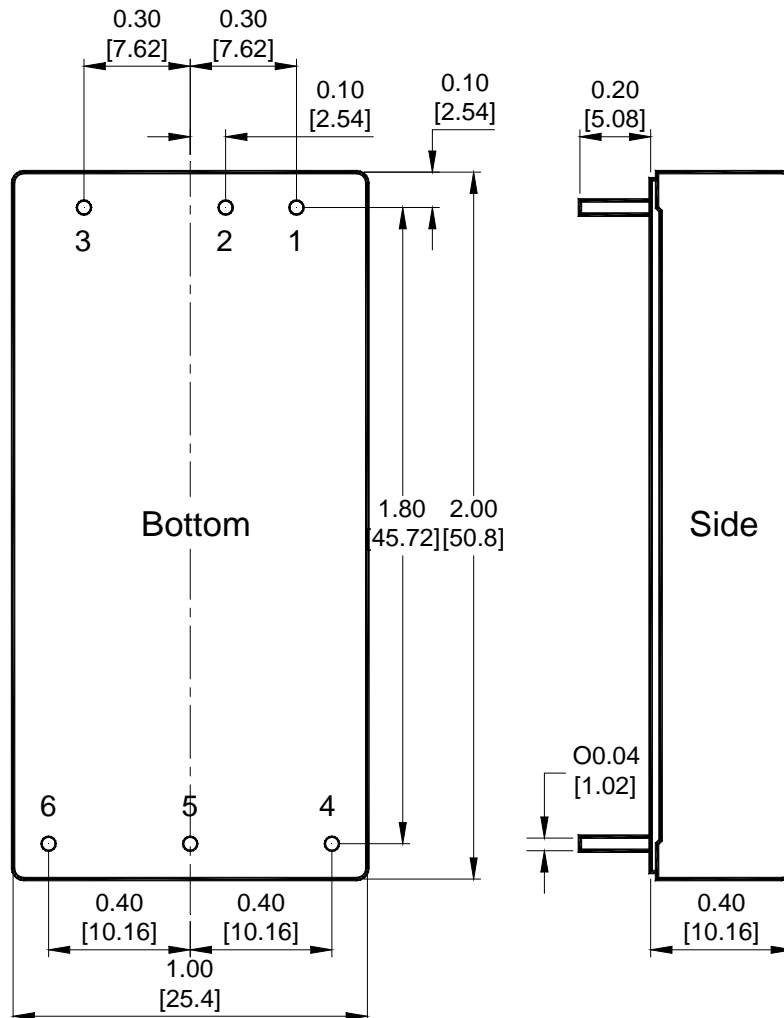

Dimensions and Pin Connections

Designation	Function Description	Pin #
+Vi	Positive input	1
-IN	Negative input	2
Remote	ON/OFF control	3
+Vo	Positive output	4
-Vo	Negative output	5
TRIM	Output voltage adjust	6

Dimensions: inches (mm)

Tolerances: .xx±0.02 (.x±0.5)
.xxx±0.01 (.x±0.25)

Weight: 35g

Base plate: Non-conductive

Pin material: Copper alloy or Brass

Pin plating: Golden over Nickel

Aurora Converter

REFERENCED EMC CIRCUIT

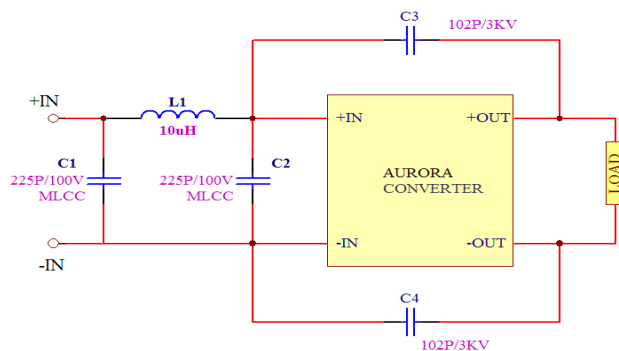
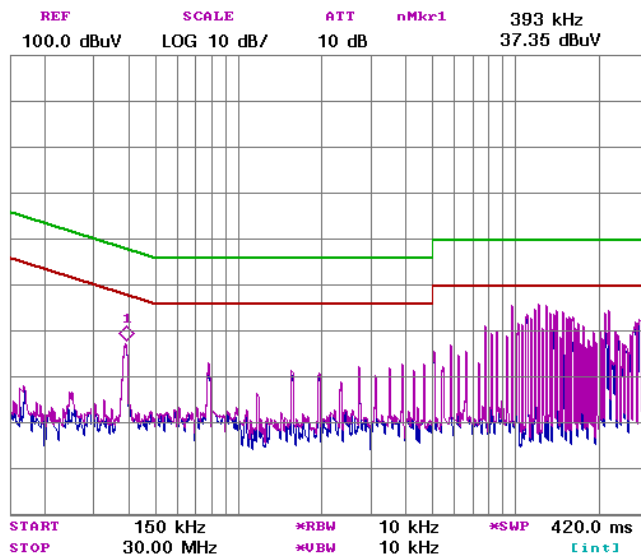

Measured conductive level of AB48050abcd-08XXX
and referenced filter circuit

Referenced EMC Performance

The tested result shown in left-hand side is obtained by loading the power module with a resistive load only. It can be used as a design reference for customer system. However! The performance of customer's system depends on the whole system design. It should be noted that modifications on the circuit parameters and fine adjustment of the final layout affect the final EMC performance greatly.

Bandwidth of EMC Components

No components are ideal for infinite frequency range. The bandwidth of EMC components should be taking into consideration when designing an EMC filter circuit. To connect ceramic capacitor with electricity capacitor in parallel and connect low inductance inductor with big one could get a better bandwidth.

NOTE:

1. It is recommended that the input should be protected by fuses or other protection devices.
2. All specifications are typical at nominal input, full load and 25°C unless otherwise noted.
3. Specifications are subject to change without notice.
4. Printed or downloaded datasheets are not subject to Glary document control.
5. Product labels shown, including safety agency certificates, may vary based on the date of manufacture.
6. Information provided in this documentation is for ordering purposes only.
7. This product is not designed for use in critical life support systems, equipment used in hazardous environments, nuclear control systems or other such applications, which necessitate specific safety and regulatory standards other than the ones listed in this datasheet.

IMPORTANT

- ✳ General specifications and the performances are related to standard series only, no special customer specification display here except requested items.
- ✳ In order to secure effective usage of converter and the validity of Glary's service and warranty coverage, please refer to the application notes for general usage. For needs of usage beyond the application notes, please contact to Glary headquarter or our regional sales representative office for help.