

Glary Power Technology

COE Series Eighth Brick up to 132W/50A

Efficiency >92%	175W/in ³	Open Frame Package	OCP	4.8Mhrs MTBF
Remote ON/OFF	INPUT 2:1	OVP	OTP	
 				



The **COE** series provides up to 132W/50A outputs with industry standard eighth brick pin assignment. The efficient SR stage is combined with patented “Buck Reset” topology that would reduce power loss to achieve 175W/in³ power density. The multi-layer single side circuit board design plus the Sink-plate technology would enhance the thermal performance and improve its reliability. Modules are designed for Telecom, Servers, Networking equipments and other applications that use a 24V or 48V input bus.

PART NUMBER SYSTEM

COE	48	120	a	b	c	d	-	11	XX	X
Series Name	Input Voltage	Output Voltage	Enable Logic	Pin Dimension	Standoff Height	Base-Plate		Output Current	Suffix	Version
COE	48=36V~75V 24=18V~36V	Unit: 0.1V Increments 120=12V 050=5V	P: Positive N: Negative	0 : 0.12" 1 : 0.16" 2 : 0.20" 3 : 0.24"	0 : 0.02" 1 : 0.08" 2 : 0.16"	M : 1.0mm Metal Plate S : 3.0mm Metal Plate A : 3.0mm Sink-Plate B : 5.0mm Sink-Plate		00~50 : For output current rating	For marketing purpose only	

MODEL LIST (Contact to factory for special input / output)

Part Number *	Maximum Input	Maximum Output	Efficiency	Part Number *	Maximum Input	Maximum Output	Efficiency				
COE48120abcd-11XXX	36V~75V	145W	12.0V/11A	132W	92%	COE24120abcd-10XXX	18V~36V	133W	12.0V/10A	120W	92%
COE48070abcd-18XXX	36V~75V	138W	7.0V/18A	126W	91%	COE24050abcd-25XXX	18V~36V	139W	5.0V/25A	125W	91%
COE48050abcd-25XXX	36V~75V	138W	5.0V/25A	125W	91%	COE24033abcd-30XXX	18V~36V	111W	3.3V/30A	99W	90%
COE48033abcd-30XXX	36V~75V	111W	3.3V/30A	99W	90%	COE24025abcd-40XXX	18V~36V	114W	2.5V/40A	100W	89%
COE48025abcd-40XXX	36V~75V	114W	2.5V/40A	100W	89%	COE24018abcd-50XXX	18V~36V	106W	1.8V/50A	90W	87%
COE48018abcd-50XXX	36V~75V	106W	1.8V/50A	90W	87%	COE24015abcd-50XXX	18V~36V	90W	1.5V/50A	75W	85%
COE48015abcd-50XXX	36V~75V	90W	1.5V/50A	75W	85%						

REFERENCED THERMAL IMAGES

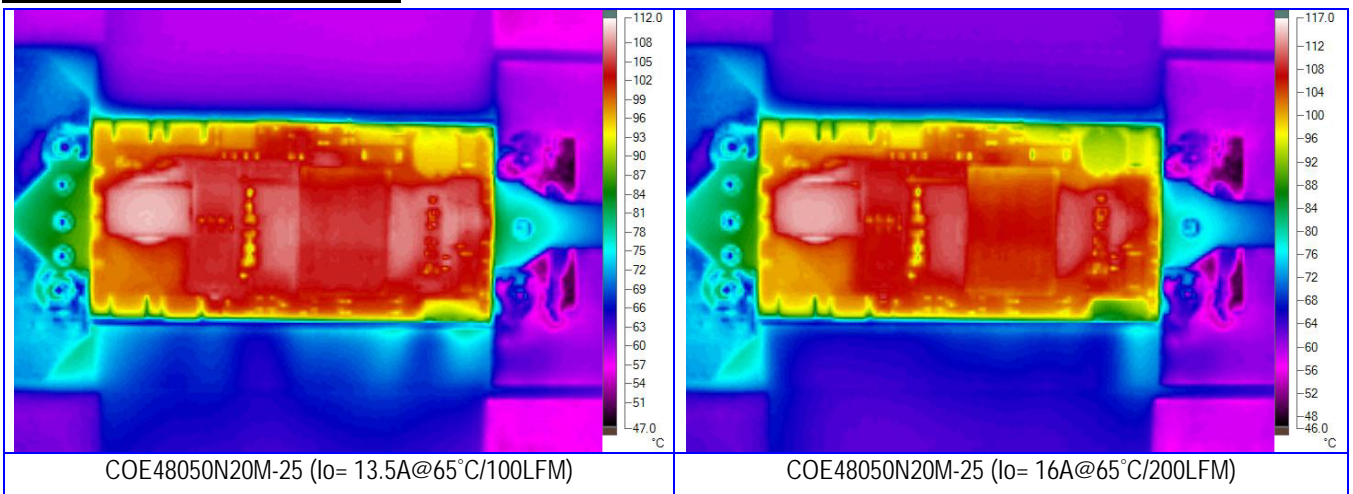

COE Series**SPECIFICATIONS**

Absolute Maximum Ratings		
Temperature	Operation Storage	-40°C to +110°C -55°C to +125°C
Input Voltage Range	Operation: 24V Models 48V Models Transient (100mS): 24V Models 48V Models	-0.5V to +40Vdc -0.5V to +80Vdc 50V Maximum 100V Maximum
Isolation Voltage	Input to Output Input to Case Output to Case	2.0KV Minimum 1.0KV Minimum 1.0KV Minimum
Remote Control		-0.5V to +12Vdc

General Parameters

Conversion Efficiency	Typical	See table
Switching Frequency	Typical	330KHz
MTBF	Bellcore TR-332 issue 6	4.80x10 ⁶ hrs @GB/25°C (COE48050abcc-25XXX)
OTP	Internal	110°C(Tc) ±5°C
Weight	1.0mm metal plate 3.0mm metal plate	27g 32g

Control Functions

Remote Control	Logic High Logic Low	+3.0V to +6.5V 0V to +1.0V
Input Current of Remote Control Pin		-0.5mA ~ +1.5mA

Input

Operation Voltage Range	24V Models 48V Models	+18V to +36Vdc +36V to +75Vdc
Reflected Ripple Current	L _{EXT} = 10uH	20mA rms/60mAp-p
Power ON Voltage Ranges	24V Models 48V Models	+17.0V to +18.0Vdc +34.0V to +36.0Vdc
Power OFF Voltage Ranges	24V Models 48V Models	+15.6V to +16.6Vdc +31.2V to +33.2Vdc
Off State Input Current	V _{NOM}	6mA Max
Latch-State Input Current	V _{NOM}	8mA Max
Input Capacitance	24V Models 48V Models	22.0uF Max 10.0uF Max

Output

Voltage Accuracy	Typical	±1.0%
Line Regulation	Full Input Range	±0.2%
Load Regulation	0%~100%	±0.2%
Temperature Drift	-40°C ~100°C	±0.03%/°C
Output Tolerance Band	All Conditions	±4%
Ripple & Noise (20MHz)	Peak-Peak (RMS)	3% (1%) V _O
Over Voltage Protection	V _{NOM} , 10% Load	115~130 %V _O
Output Current Limits	V _{NOM}	108%~125%
Voltage Trim	V _{NOM} , 10% Load	±10%
Input Ripple Rejection (<1KHz)	V _{NOM} , Full Load	-50dB
Step Load (2.5A/μS)	50%~75% Load	±6%Vo/500μS
Start-Up Delay Time	V _{NOM} , Full Load	20mS/250mS

COE Series

TYPICAL WAVES AND CURVES

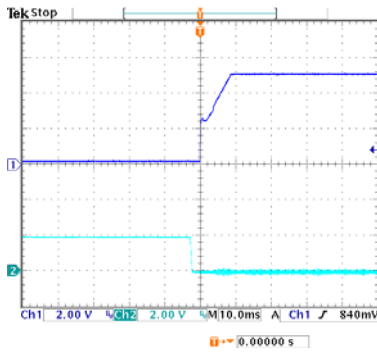

Start-up waveform of COE48050abcd-25XXX
(V_{IN} : 50V, Load: 25A)

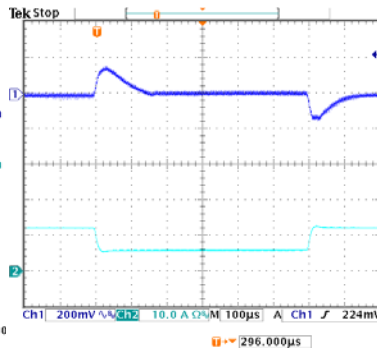

Transient response of COE48050abcd-25XXX
(V_{IN} : 50V, Load: 12.5A/5.0A@2.5A/µs)

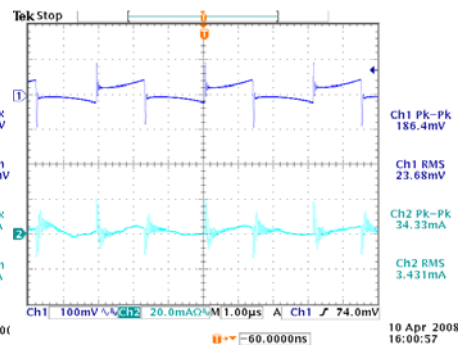

Input/Output ripples of COE48050abcd-25XXX
(V_{IN} : 50V, Load: 25A, L_{IN} =10uH)

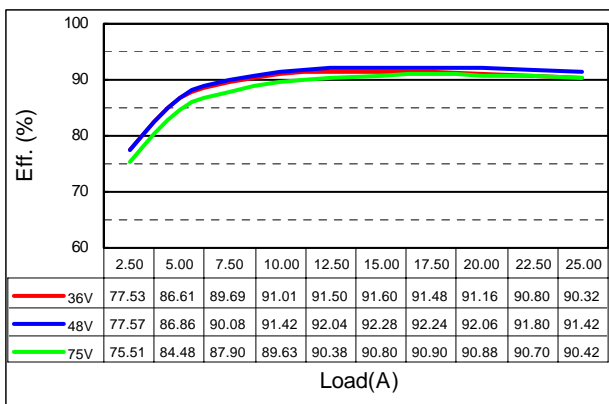

Efficiency plot of COE48050abcA-25XXX

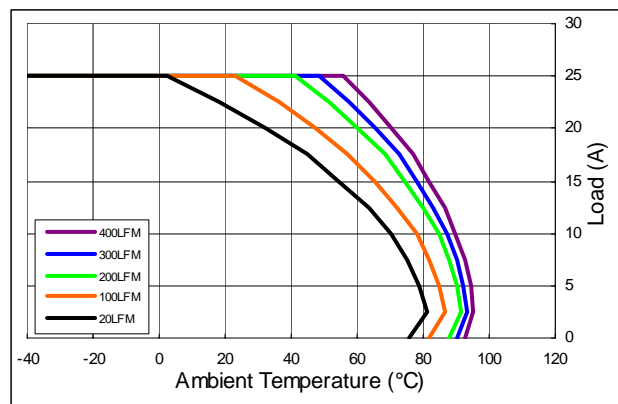

Derating curves of COE48050abcA-25XXX for $T_C=110^{\circ}C$

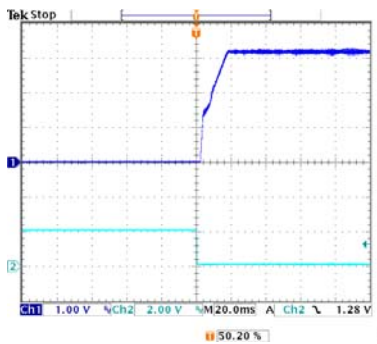

Start-up waveform of COE48033abcd-30XXX
(V_{IN} : 48V, Load: 30A)

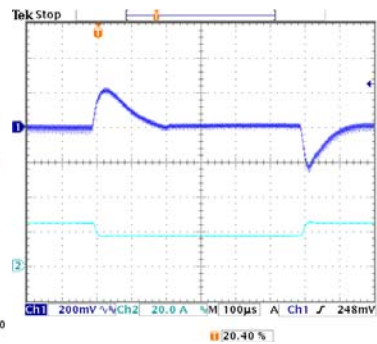

Transient response of COE48033abcd-30XXX
(V_{IN} : 48V, Load: 25A/16A@2.5A/µs)

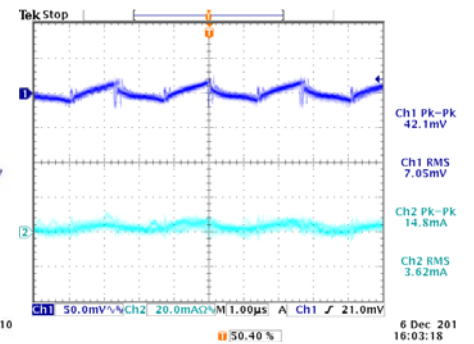

Input/Output ripples of COE48033abcd-30XXX
(V_{IN} : 48V, Load: 30A, L_{IN} =10uH)

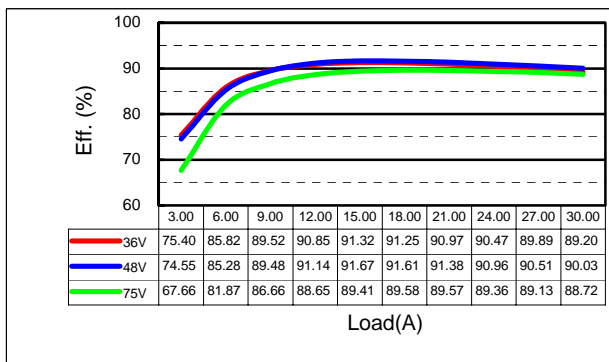

Efficiency plot of COE48033abcA-30XXX

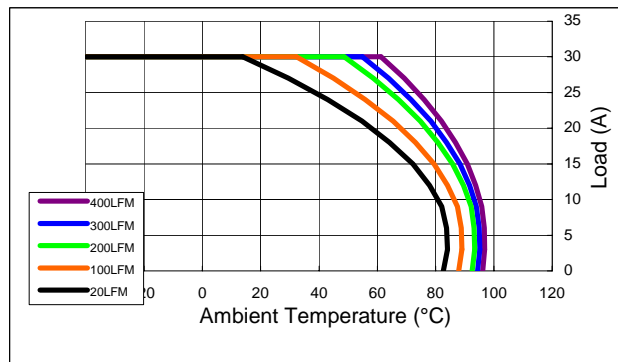

Derating curves of COE48033abcA-30XXX for $T_C=110^{\circ}C$

COE Series

OPEN FRAME PACKAGE

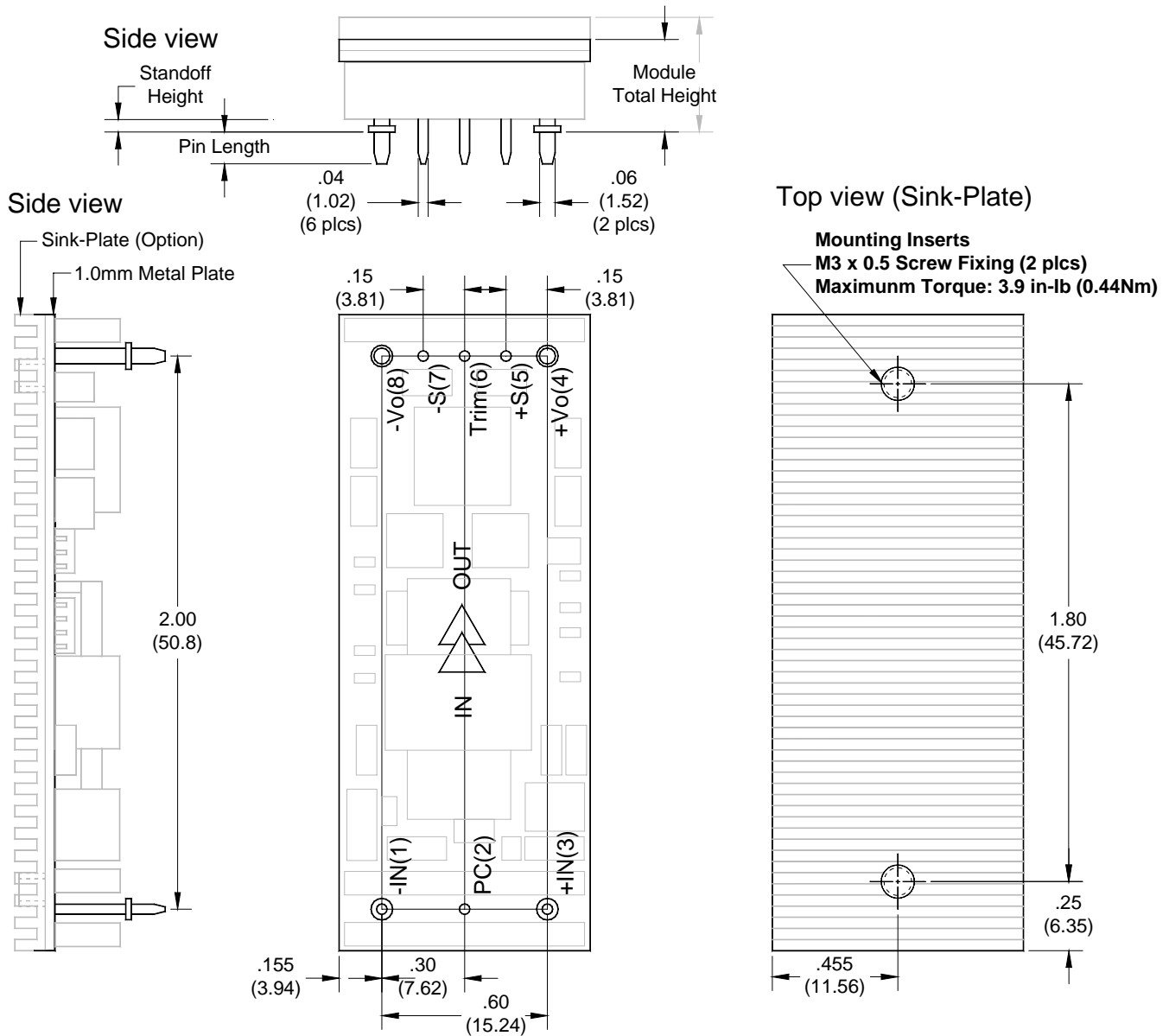

Dimensions and Pin Connections

Designation	Function Description	Pin #
-IN	Negative input	1
PC	Remote control. To turn-on and turn-off output.	2
+IN	Positive input	3
+Vo	Positive output	4
+S	Positive remote sense	5
TRIM	Output voltage adjust	6
-S	Negative remote sense	7
-Vo	Negative output	8

Dimensions: inches (mm)

Tolerances: .xx±0.02 (.x±0.5)
.xxx±0.01 (.x±0.25)

Weight: 27g / 1.0mm metal plate
32g / 3.0mm metal plate

Base plate: Aluminum alloy with anode oxide

Mounting inserts: Stainless steel
Maximum torque: 3.9 in-lb (0.44Nm)

Pin material: Copper alloy or Brass

Pin plating: Golden over Nickel

COE Series

REFERENCED EMC CIRCUIT

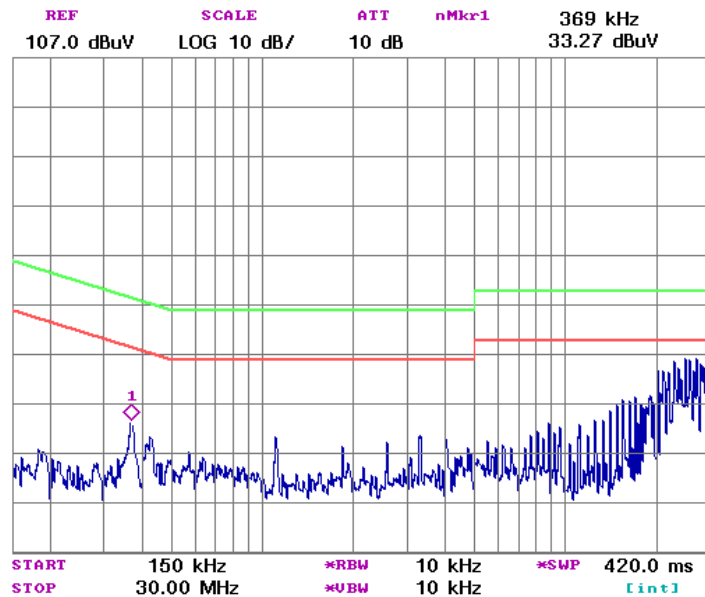

Referenced EMC Performance

The tested result shown in left-hand side is obtained by loading the power module with a resistive load only. It can be used as a design reference for customer system. However! The performance of customer's system depends on the whole system design. It should be noted that modifications on the circuit parameters and fine adjustment of the final layout affect the final EMC performance greatly.

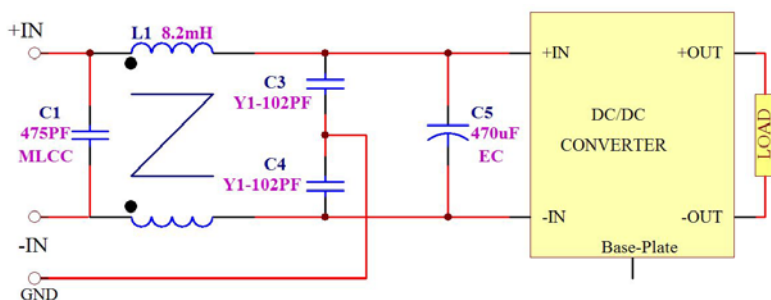

Measured conductive level of COE48050abcd-25XXX and referenced filter circuit

Bandwidth of EMC Components

No components are ideal for infinite frequency range. The bandwidth of EMC components should be taking into consideration when designing an EMC filter circuit. To connect ceramic capacitor with electrolytic capacitor in parallel and connect low inductance inductor with big one could get a better bandwidth.

NOTE:

1. It is recommended that the input should be protected by fuses or other protection devices.
2. All specifications are typical at nominal input, full load and 25°C unless otherwise noted.
3. Specifications are subject to change without notice.
4. Printed or downloaded datasheets are not subject to Glary document control.
5. Product labels shown, including safety agency certificates, may vary based on the date of manufacture.
6. Information provided in this documentation is for ordering purposes only.
7. This product is not designed for use in critical life support systems, equipment used in hazardous environments, nuclear control systems or other such applications, which necessitate specific safety and regulatory standards other than the ones listed in this datasheet.

IMPORTANT

- ✳ General specifications and the performances are related to standard series only, no special customer specification display here except requested items.
- ✳ In order to secure effective usage of converter and the validity of Glary's service and warranty coverage, please refer to the application notes for general usage. For needs of usage beyond the application notes, please contact to Glary headquarter or our regional sales representative office for help.



The **Enclosed COE** series provides up to 130W/50A outputs with industry standard eighth brick pin assignment. The high thermal conductivity silicone potted six-sides metal package is designed for applications under extreme environmental conditions. The efficient SR stage is combined with patented "Buck Reset" topology that would reduce power loss to achieve 102W/in³ power density. The multi-layer single side circuit board design plus the metal-plate technology would enhance the thermal performance and improve its reliability. Modules are designed for Telecom, Servers, Networking equipments and other applications that use a 24V or 48V input bus.

PART NUMBER SYSTEM

COE	48	120	a	b	c	d	-	11	XX	X
Series Name	Input Voltage	Output Voltage	Enable Logic	Pin Dimension	Standoff Height	Base-Plate		Output Current	Suffix	Version
COE	48=36V~75V 24=18V~36V	Unit: 0.1V Increments 120=12V 050=5V	P: Positive N: Negative	0 : 0.12" 1 : 0.16" 2 : 0.20" 3 : 0.24"	0 : 0.02"	U : 3.0mm Metal Plate V : 5.0mm Metal Plate W : 3.0mm Sink Plate	-	00~50 : For output current rating	For marketing purpose only	

MODEL LIST (Contact to factory for special input / output)

Part Number *	Maximum Input	Maximum Output	Efficiency	Part Number *	Maximum Input	Maximum Output	Efficiency
COE48120abcd-11XXX	36V~75V 145W	12.0V/11A 132W	92%	COE24120abcd-10XXX	18V~36V 133W	12.0V/10A 120W	92%
COE48070abcd-18XXX	36V~75V 138W	7.0V/18A 126W	91%	COE24050abcd-25XXX	18V~36V 139W	5.0V/25A 125W	91%
COE48050abcd-25XXX	36V~75V 138W	5.0V/25A 125W	91%	COE24033abcd-30XXX	18V~36V 111W	3.3V/30A 99W	90%
COE48033abcd-30XXX	36V~75V 111W	3.3V/30A 99W	90%	COE24025abcd-40XXX	18V~36V 114W	2.5V/40A 100W	89%
COE48025abcd-40XXX	36V~75V 114W	2.5V/40A 100W	89%	COE24018abcd-50XXX	18V~36V 106W	1.8V/50A 90W	87%
COE48018abcd-50XXX	36V~75V 106W	1.8V/50A 90W	87%	COE24015abcd-50XXX	18V~36V 90W	1.5V/50A 75W	85%
COE48015abcd-50XXX	36V~75V 90W	1.5V/50A 75W	85%				

REFERENCED THERMAL IMAGES

To be updated in next version	To be updated in next version

*Enclosed COE Series***SPECIFICATIONS**

Absolute Maximum Ratings		
Temperature	Operation Storage	-40°C to +110°C -55°C to +125°C
Input Voltage Range	Operation: 24V Models 48V Models Transient (100mS): 24V Models 48V Models	-0.5V to +40Vdc -0.5V to +80Vdc 50V Maximum 100V Maximum
Isolation Voltage	Input to Output Input to Case Output to Case	2.0KV Minimum 1.0KV Minimum 1.0KV Minimum
Remote Control		-0.5V to +12Vdc

General Parameters

Conversion Efficiency	Typical	See table
Switching Frequency	Typical	330KHz
MTBF	Bellcore TR-332 issue 6	4.80x10 ⁶ hrs @GB/25°C (COE48050abcc-25XXX)
OTP	Internal	110°C(Tc) ±5°C
Weight	3.0mm metal plate 5.0mm metal plate	55g 65g

Control Functions

Remote Control	Logic High Logic Low	+3.0V to +6.5V 0V to +1.0V
Input Current of Remote Control Pin		-0.5mA ~ +1.5mA

Input

Operation Voltage Range	24V Models 48V Models	+18V to +36Vdc +36V to +75Vdc
Reflected Ripple Current	L _{EXT} = 10uH	20mA rms/60mAp-p
Power ON Voltage Ranges	24V Models 48V Models	+17.0V to +18.0Vdc +34.0V to +36.0Vdc
Power OFF Voltage Ranges	24V Models 48V Models	+15.6V to +16.6Vdc +31.2V to +33.2Vdc
Off State Input Current	V _{NOM}	6mA Max
Latch-State Input Current	V _{NOM}	8mA Max
Input Capacitance	24V Models 48V Models	22.0uF Max 10.0uF Max

Output

Voltage Accuracy	Typical	±1.0%
Line Regulation	Full Input Range	±0.2%
Load Regulation	0%~100%	±0.2%
Temperature Drift	-40°C ~100°C	±0.03%/°C
Output Tolerance Band	All Conditions	±4%
Ripple & Noise (20MHz)	Peak-Peak (RMS)	3% (1%) V _O
Over Voltage Protection	V _{NOM} , 10% Load	115~130 %V _O
Output Current Limits	V _{NOM}	108%~125%
Voltage Trim	V _{NOM} , 10% Load	±10%
Input Ripple Rejection (<1KHz)	V _{NOM} , Full Load	-50dB
Step Load (2.5A/μS)	50%~75% Load	±6%Vo/500μS
Start-Up Delay Time	V _{NOM} , Full Load	20mS/250mS

Enclosed COE Series

TYPICAL WAVES AND CURVES

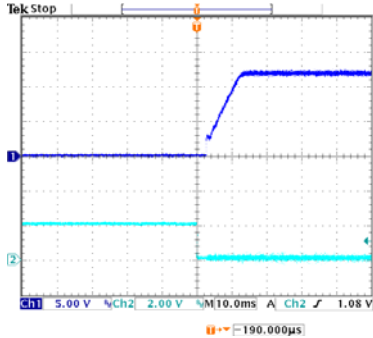

Start-up waveform of COE48120abcd-11XXX
(V_{IN} : 48V, Load: 11A)

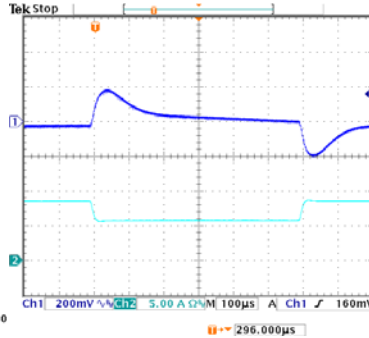

Transient response of COE48120abcd-11XXX
(V_{IN} : 48V, Load: 8.5A/5.5A@2.5A/µs)

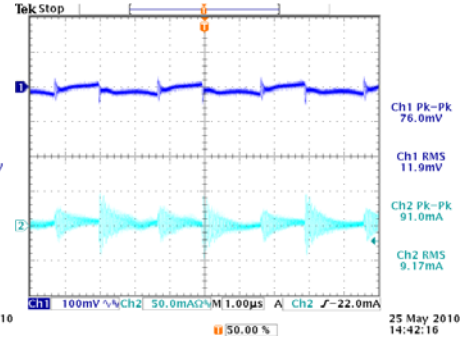

Input/Output ripples of COE48120abcd-11XXX
(V_{IN} : 48V, Load: 11A, L_{IN} =10uH)

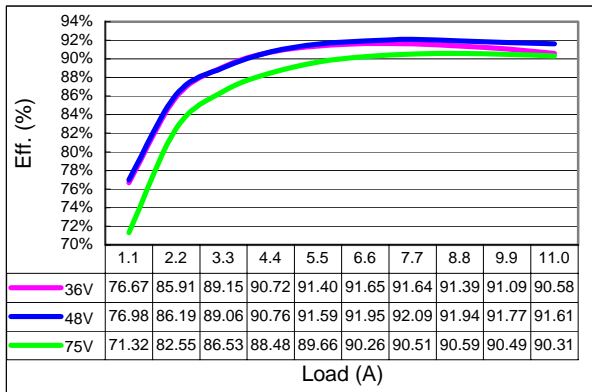

Efficiency plot of COE48120abcA-11XXX

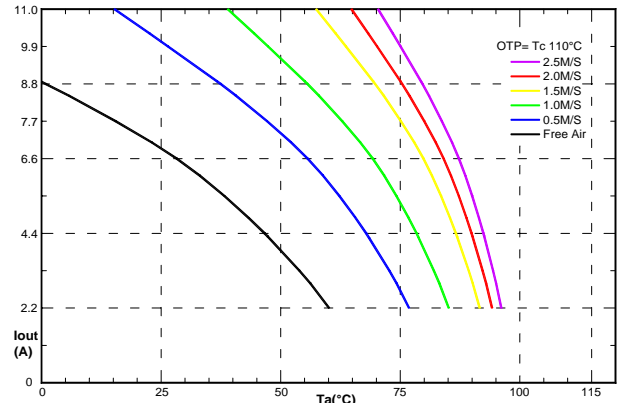

Derating curves of COE48120abcA-11XXX for $T_C = 110^\circ\text{C}$

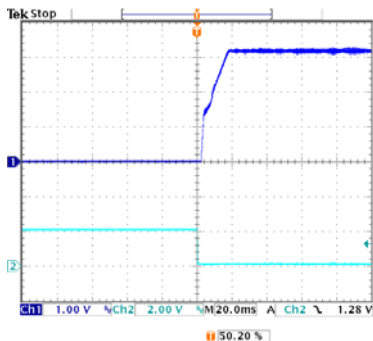

Start-up waveform of COE48033abcd-30XXX
(V_{IN} : 48V, Load: 30A)

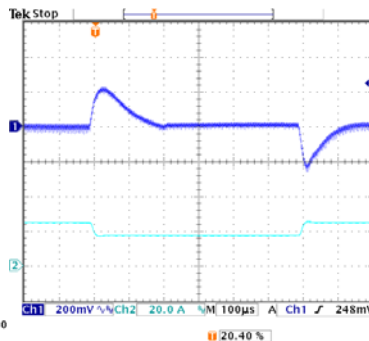

Transient response of COE48033abcd-30XXX
(V_{IN} : 48V, Load: 25A/16A@2.5A/µs)

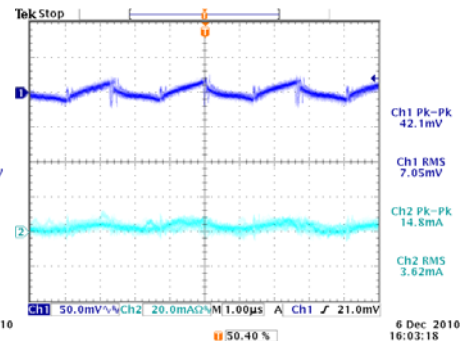

Input/Output ripples of COE48033abcd-30XXX
(V_{IN} : 48V, Load: 30A, L_{IN} =10uH)

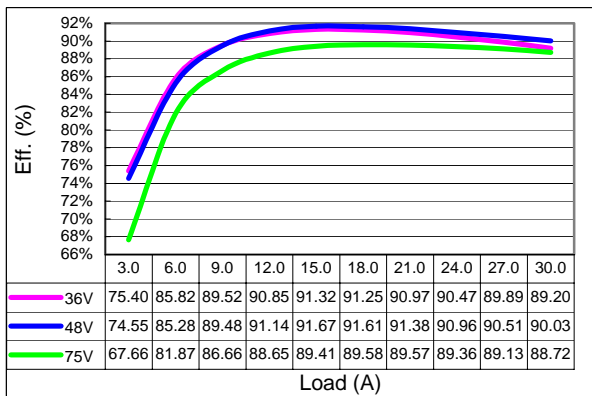

Efficiency plot of COE48033abcA-30XXX

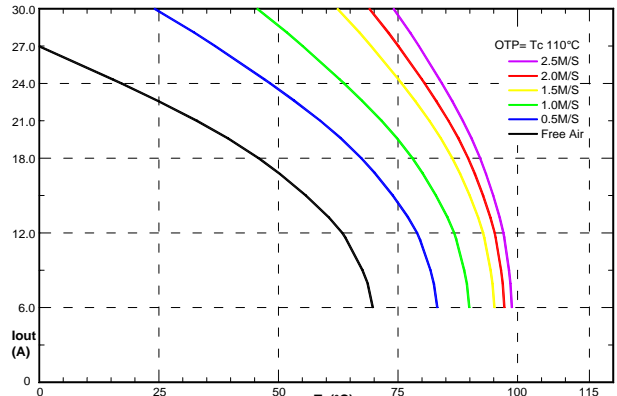

Derating curves of COE48033abcA-30XXX for $T_C = 110^\circ\text{C}$

Enclosed COE Series

METAL ENCLOSED PACKAGE

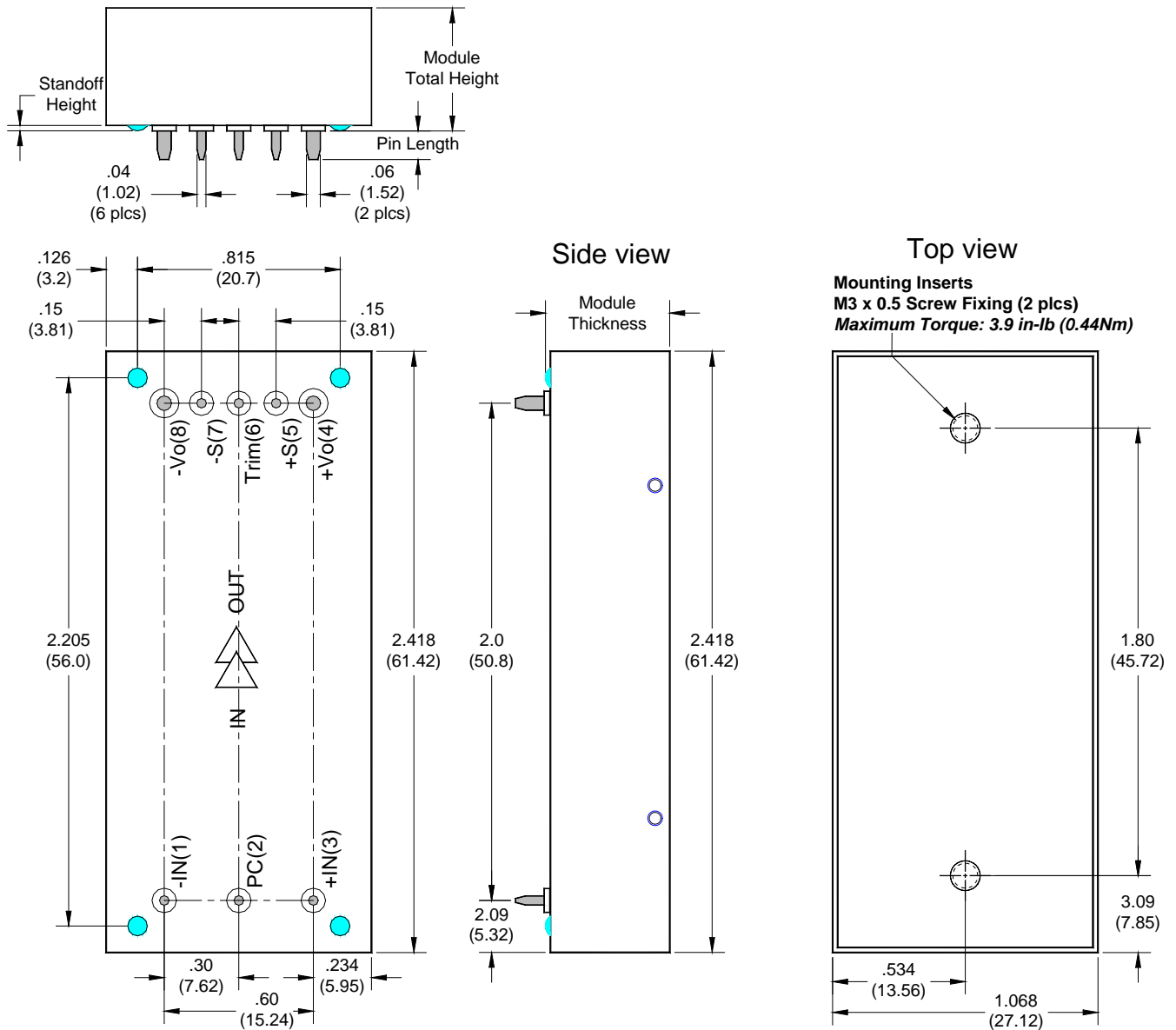

Dimensions and Pin Connections

Designation	Function Description	Pin #
-IN	Negative input	1
PC	Remote control. To turn-on and turn-off output.	2
+IN	Positive input	3
+Vo	Positive output	4
+S	Positive remote sense	5
TRIM	Output voltage adjust	6
-S	Negative remote sense	7
-Vo	Negative output	8

Dimensions: inches (mm)

Tolerances: .xx±0.02 (.x±0.5)
.xxx±0.01 (.x±0.25)

Weight: 55g / 3.0mm metal plate
65g / 5.0mm metal plate

Base plate: Aluminum alloy with anode oxide

Mounting inserts: Stainless steel
Maximum torque: 3.9 in-lb (0.44Nm)

Pin material: Copper alloy or Brass

Pin plating: Golden over Nickel

Enclosed COE Series

REFERENCED EMC CIRCUIT

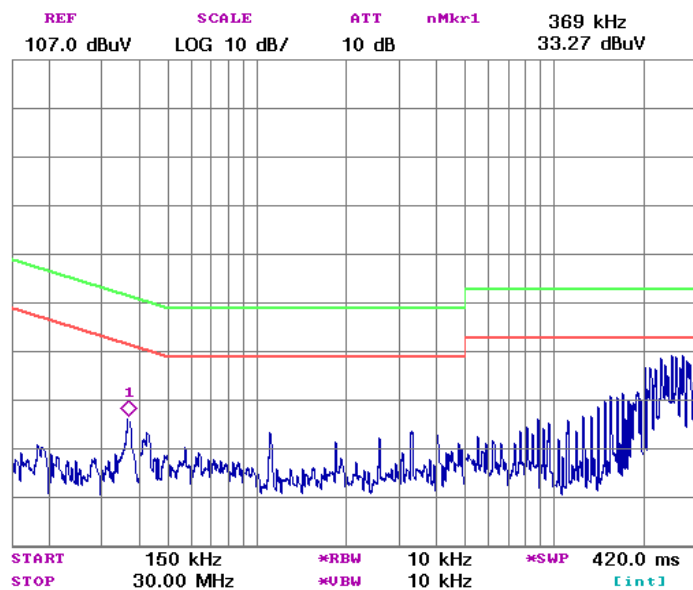

Referenced EMC Performance

The tested result shown in left-hand side is obtained by loading the power module with a resistive load only. It can be used as a design reference for customer system. However! The performance of customer's system depends on the whole system design. It should be noted that modifications on the circuit parameters and fine adjustment of the final layout affect the final EMC performance greatly.

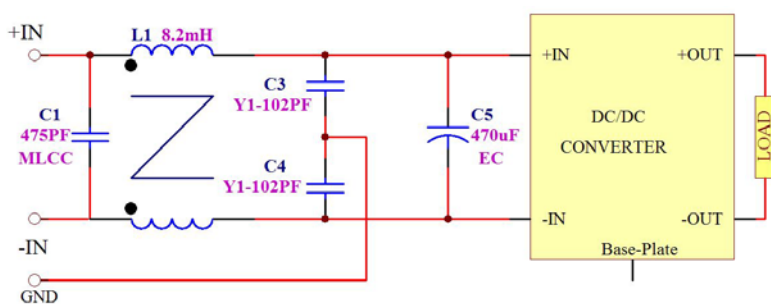

Measured conductive level of COE48050abcd-25XXX
and referenced filter circuit

Bandwidth of EMC Components

No components are ideal for infinite frequency range. The bandwidth of EMC components should be taking into consideration when designing an EMC filter circuit. To connect ceramic capacitor with electrolytic capacitor in parallel and connect low inductance inductor with big one could get a better bandwidth.

NOTE:

1. It is recommended that the input should be protected by fuses or other protection devices.
2. All specifications are typical at nominal input, full load and 25°C unless otherwise noted.
3. Specifications are subject to change without notice.
4. Printed or downloaded datasheets are not subject to Glary document control.
5. Product labels shown, including safety agency certificates, may vary based on the date of manufacture.
6. Information provided in this documentation is for ordering purposes only.
7. This product is not designed for use in critical life support systems, equipment used in hazardous environments, nuclear control systems or other such applications, which necessitate specific safety and regulatory standards other than the ones listed in this datasheet.

IMPORTANT

- ✳ General specifications and the performances are related to standard series only, no special customer specification display here except requested items.
- ✳ In order to secure effective usage of converter and the validity of Glary's service and warranty coverage, please refer to the application notes for general usage. For needs of usage beyond the application notes, please contact to Glary headquarter or our regional sales representative office for help.