

NMOP-10130

SURFACE MOUNT LED TAPE AND REEL

Features:

1. Top view LED.
2. Small package with high efficiency
3. Soldering methods: IR reflows soldering.
4. RoHS compliant
5. Pb Free

Applications:

1. LCD back light.
2. Mobile phones.
3. Indicators.
4. Switch lights.

Device Selection Guide

Part No	Material	Color	
		Emitted	Lens
NMOP-10130	InGaN	Green	Water Clear

Package Dimensions

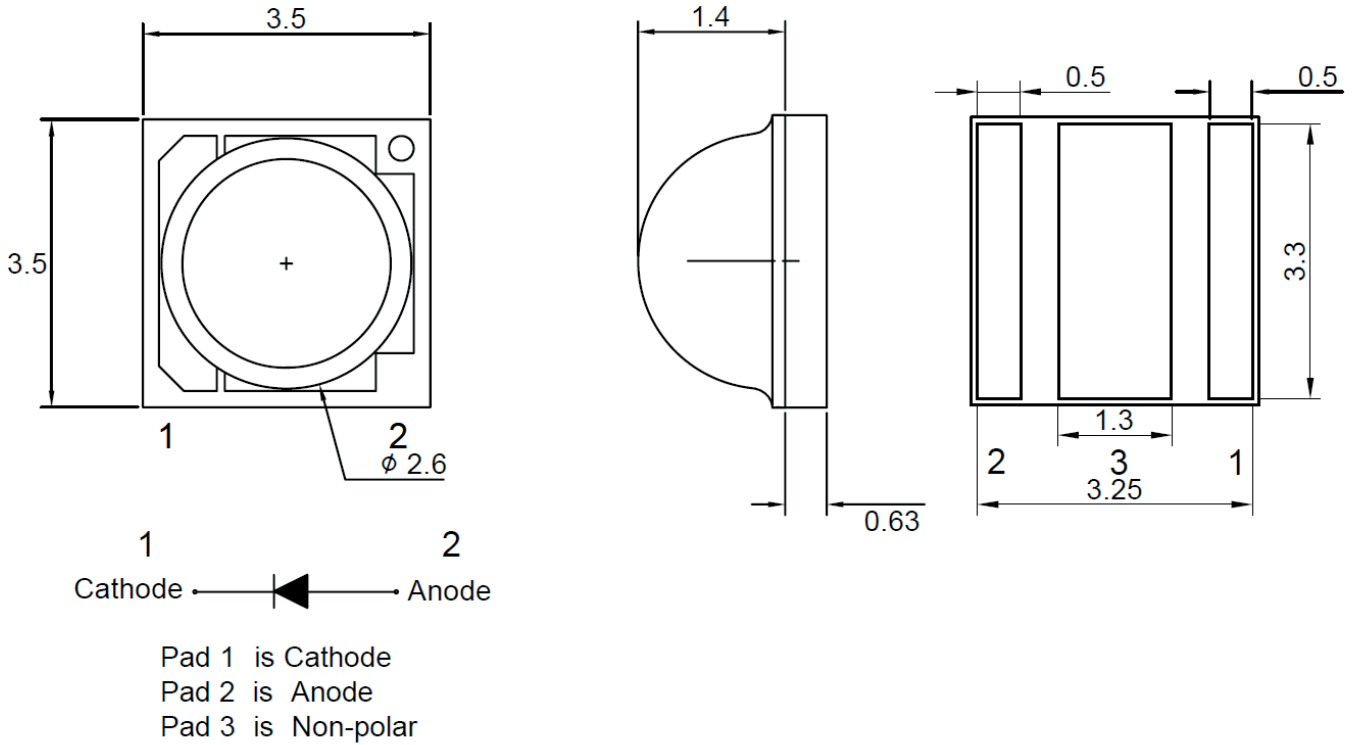

Note : 1. All dimension are in millimeter tolerance is $\pm 0.2\text{mm}$ unless otherwise noted.
 2. Specifications are subject to change without notice.

Recommended Soldering Pad Dimensions

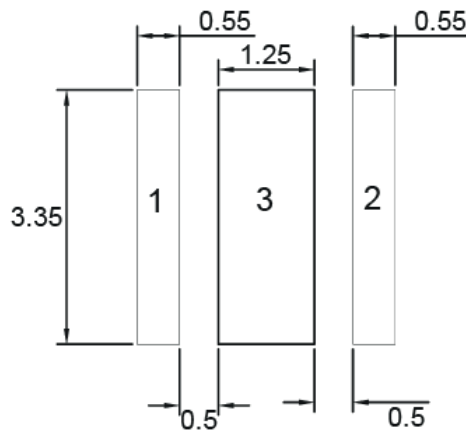

Note : The tolerances unless mentioned is $\pm 0.1\text{mm}$, Unit=mm.

Absolute Maximum Ratings at Ta=25° C

Parameter	Symbol	Ratings	UNIT
Power Dissipation	Pd	1.33	W
DCForward Current	I _F	350	mA
Reverse Current (VR=5V)	I _r	10	μA
Peak Pulse Current Duty 1/10@10KHz	I _{FP}	700	mA
ESD Sensitivity	HBM 100pf/1.5 KΩ	500	V
	MM 200pf/0Ω	150	V
LED junction Temperature	T _j	115	°C
Thermal resistance	R _{th}	10	°C/W
Operating Temperature	T _{opr}	-40 ~+85	°C
Storage Temperature	T _{stg}	-40 ~+100	°C
Soldering Temperature	T _p	260	°C

Typical Electrical & Optical Characteristics (Ta=25° C)

Parameter	Symbol	Min.	Typ.	Max.	Unit	Condition
Luminous Intensity	I _v	45	60	---	Lm	IF=350mA
Dominant Wavelength	λ _D	519	---	531	nm	IF=350mA
Spectral Line Half Width	Δλ	---	36	---	nm	IF=350mA
Forward Voltage	V _F	2.8	---	3.8	V	IF=350mA
Viewing Angle	2θ _{1/2}	130			deg	IF=350mA

- Note :
1. The forward voltage data did not including ±0.1V testing tolerance.
 2. The luminous intensity data did not including ±15% testing tolerance.
 3. The dominant wavelength data did not including ±1nm testing tolerance.

Luminous Intensity Classification

BIN Code	IV(Lm) at 350mA	
	Min.	Max.
F45V	45	55
F55V	55	65
F65V	65	75
F75V	75	85

Dominant Wavelength Classification

BIN Code	λ_D (nm) at 350mA	
	Min.	Max.
1O	519	522
1P	522	525
1Q	525	528
1R	528	531

Forward Voltage Classification

BIN Code	Vf(v) at 350mA	
	Min.	Max.
1	2.8	3.0
2	3.0	3.2
3	3.2	3.4
4	3.4	3.6
5	3.6	3.8

Typical Electro-Optical Characteristics Curve

Fig.1 Relative Intensity VS. Forward Current

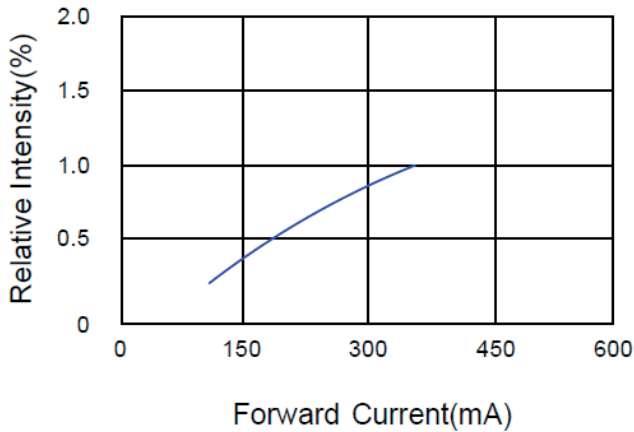

Fig.2 Forward Current VS. Ambient Temperature

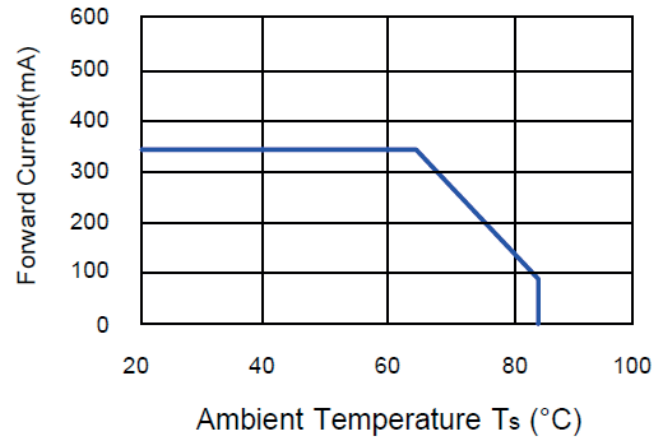

Fig.3 Relative Radiant Power VS. Wavelength

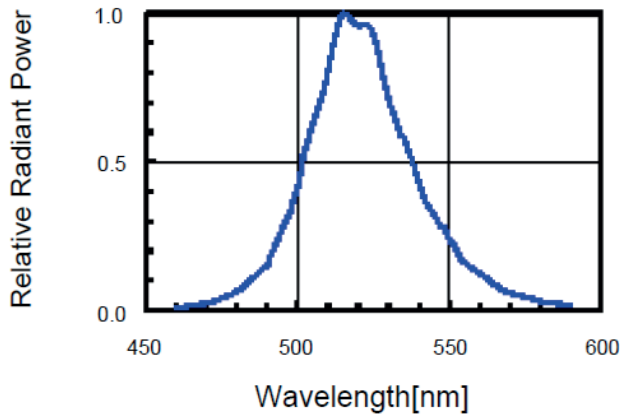

Fig.4 Forward Voltage VS. Forward Current

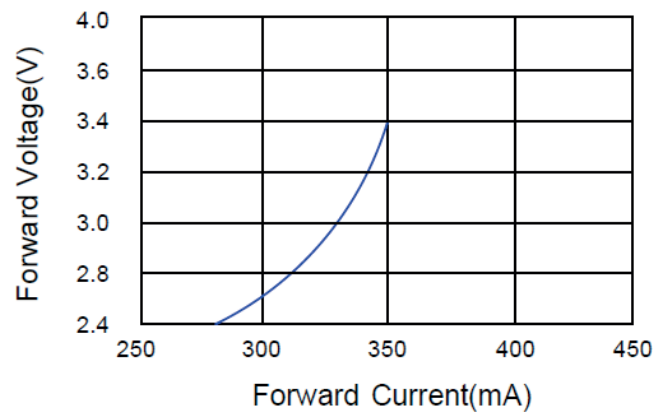
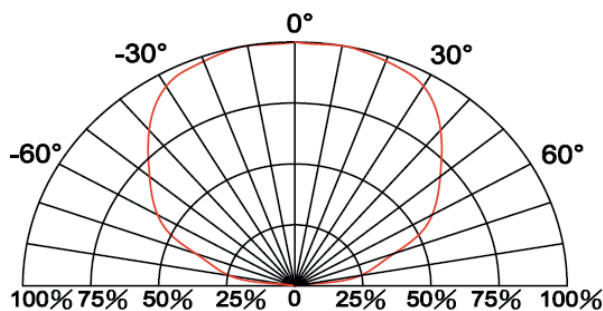
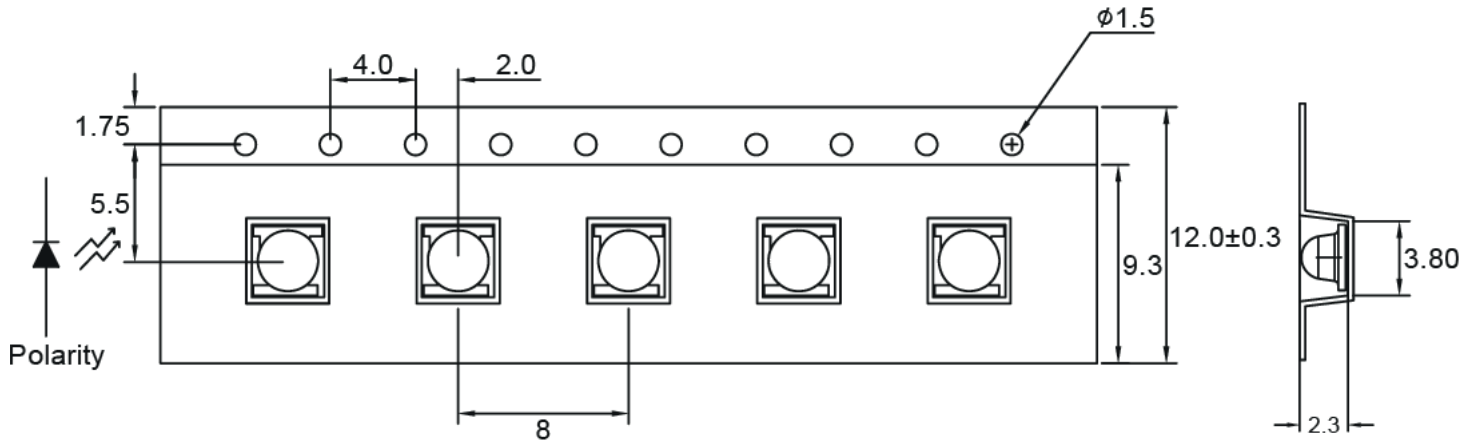

Fig.5 Directive Radiation



Carrier Type Dimensions



Note : The tolerances unless mentioned is ±0.1mm, Angle± 0.5. Unit=mm.

Packing Specifications

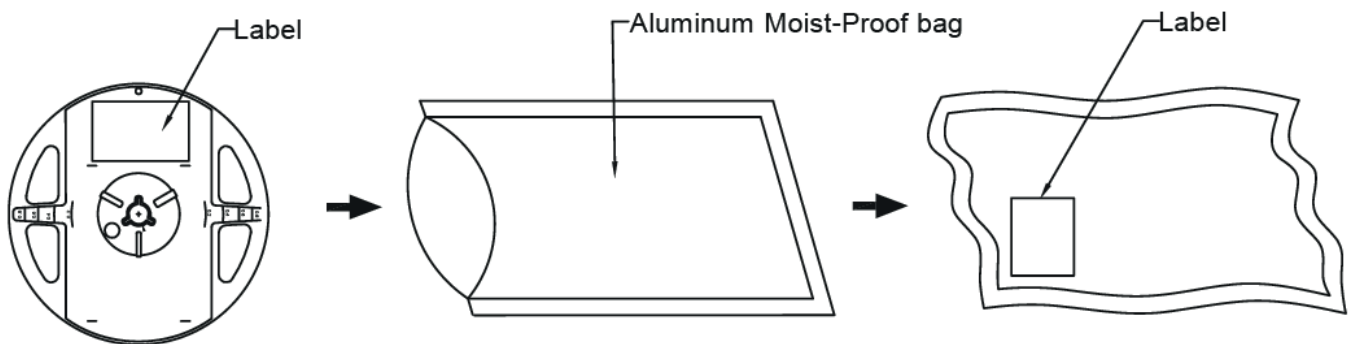

Part No.	Description	Quantity/Reel
NMOP-10130	12.0mm tape, 7" reel	500 PCS

Label Explanation



BIN : Radiant Intensity Classification

HUE : Dominant Wavelength

VF : Forward Voltage

Reel Dimensions

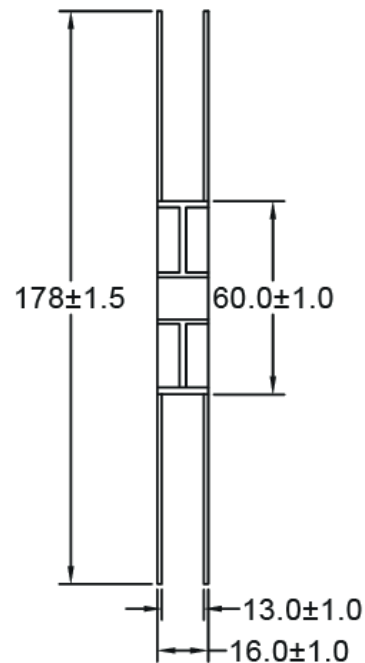
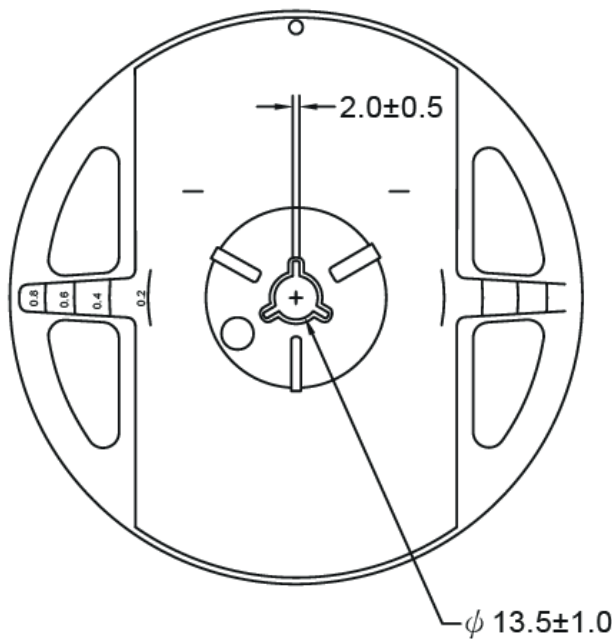

NMOP-10130

Box Explanation

1. 4 BAG / INNER BOX
2. INNER BOX SIZE : L X W X H 23cm X 8.5cm x 26cm

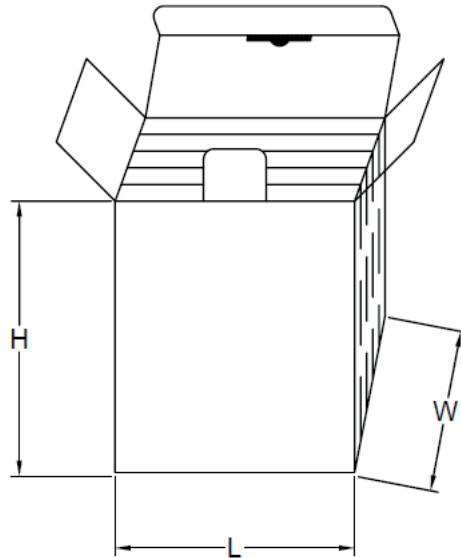

3. 10 INNER BOXES / CARTON
4. CARTON SIZE : L X W X H 58cm X 34cm x 35cm

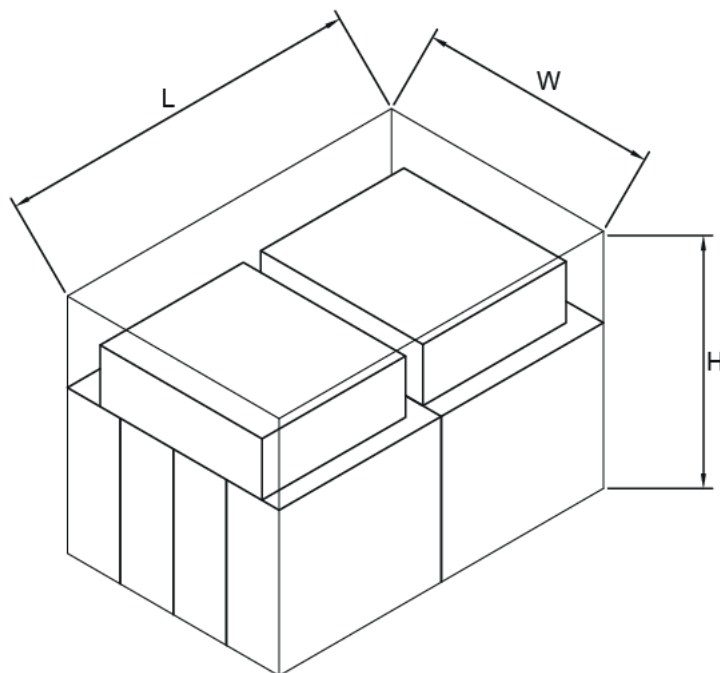

Recommended Soldering Conditions

PB-Free Reflow Solder

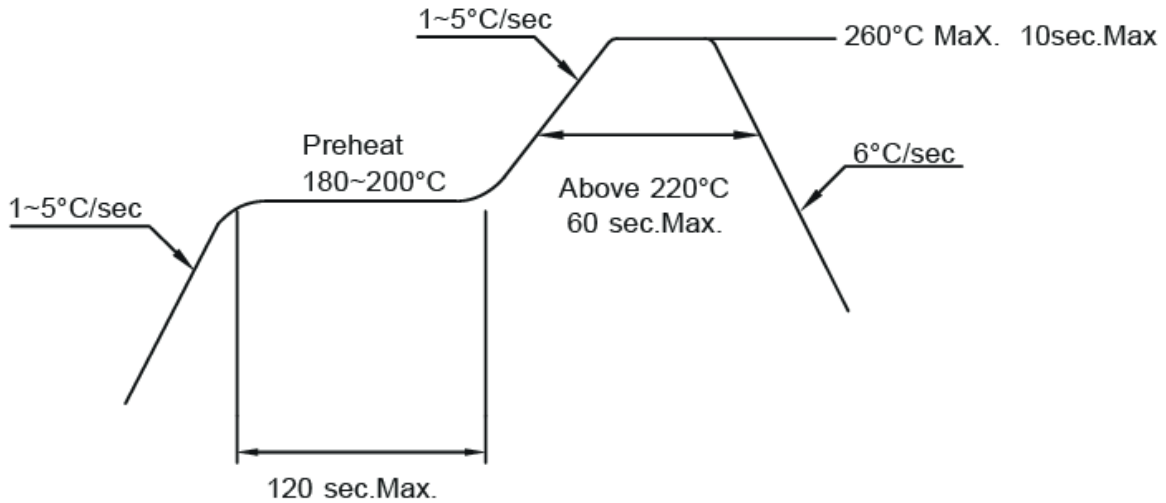

- Note:
1. Reflow soldering should not be done more than two times.
 2. When soldering, do not put stress on the LEDs during heating.
 3. After soldering, do not warp the circuit board.

Please follow the guideline to grab LEDs

- don't touch lens with the fingers
- use tweezers to grab LED
- don't apply more than 4N of lens(400G) directly onto the lens
- don't touch lens with the tweezers

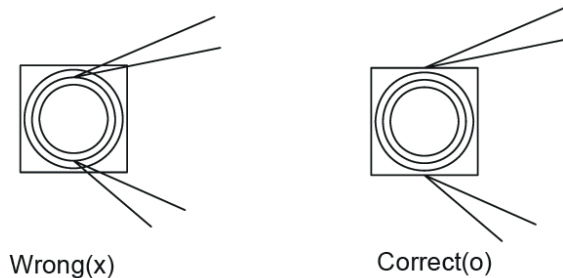

Lens cleaning

in the case where a minimal level of dirt and dust particles can not be guaranteed, a suitable cleaning solution can be applied to the lens surface

- try a gentle swabbing using a lint-free swab
- if needed, the use of lint-free swab and isopropyl alcohol used gently removes dirt from the lens
- don't use other solvents as they may directly react with the led assembly.
- don't use ultrasonic cleaning that the led will be damaged

Precautions For Use:

Storage time:

1. Calculated shelf life before opening is 12 months at $< 30^{\circ}\text{C}$ and $< 90\%$ relative humidity (RH)
2. After bag is opened, devices which will be subjected to reflow soldering or other high temperature processes must be
 - a) Assembled within 168 hours in an environment of $30^{\circ}\text{C} / 60\%$ RH, or
 - b) Stored at ambient of 10% RH or less
3. Devices are required baking before assembly if:
 - a) Humidity Indicator Card reads $>10\%$ (for level 2a -5a) or $>60\%$ (for level 2) at ambient temperature $23\pm 5^{\circ}\text{C}$
 - b) 2.a) or 2.b) doesn't meet
4. If baking is required, devices should be baked for >72 hours at $60\pm 5^{\circ}\text{C} / 5\%$ RH. Performing baking only once, and using the baked devices within 72 hours.

MSL LEVEL 3

Drive Method:

LED is a current operated device, and therefore, requires some kind of current limiting incorporated into the driver circuit. This current limiting typically takes the form of a current limiting resistor placed in series with the LED.

Consider worst case voltage variations than could occur across the current limiting resistor. The forward current should not be allowed to change by more than 40% of its desired value.

Circuit model A

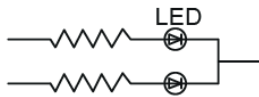

Circuit model B

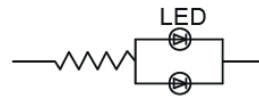

(A) Recommended circuit.

(B) The difference of brightness between LED could be found due to the VF-IF characteristics of LED.

Cleaning:

Use alcohol-based cleaning solvents such as isopropyl alcohol to clean the LED.

ESD(Electrostatic Discharge):

Static Electricity or power surge will damage the LED. Use of a conductive wrist band or anti-electrostatic glove is recommended when handling these LED. All devices, equipment and machinery must be properly grounded.

Reliability Test:

Classification	Test Item	Test Condition	Sample Size
Endurance Test	Operating Life Test	1. Ta=25°C 2. If=350mA 3. t=1000 hrs (-24hrs,+72hrs)	22
	High Temperature Storage Test	1. Ta=100°C±5°C 2. t=1000 hrs (-24hrs,+72hrs)	22
	Low Temperature Storage Test	1. Ta=-40°C±5°C 2. t=1000 hrs (-24hrs,+72hrs)	22
	High Temperature High Humidity Storage Test	1. Ta=85°C 2. RH=85% 3. t=1000hrs(-24hrs,+72hrs)	22
Environmental Test	Thermal Shock Test	1. Ta=100°C±5°C ~ -40°C±5°C 20min/ 10sec / 20min 2. total 100 cycles	22
	Temperature Cycling	1. 100°C±5°C ~ -40°C±5°C 30mins / 5mins / 30mins 2. 100 Cycles	22
	IR Reflow	1. T=260°C Max. 10sec.Max. 2. 6 Min	22