

# NMOP-2835-501-60

## SURFACE MOUNT LED TAPE AND REEL

### Features:

1. Top view white LED.
2. white SMT package.
3. Leadframe package with individual 2 pin.
4. Wide viewing angle.
5. Soldering methods:IR reflow soldering.
6. Feature of the device:more light due to higher optical efficiency;extremely wide viewing angle; ideal for backlighting and coupling in light guide.

### Descriptions:

The NMOP-2835-501-60 SMD has wide viewing angle and optimized light coupling by inter reflector,The low current requirement makes this device ideal for portable equipment or any other application where power is at a premium.

### Applications:

1. LCD back light.
2. Mobile phones.
3. Indicators.
4. Switch lights.

### Device Selection Guide

Part No	Material	Color	
		Emitted	Lens
NMOP-2835-501-60	InGaN	Green	Water Clear

## Package Dimensions

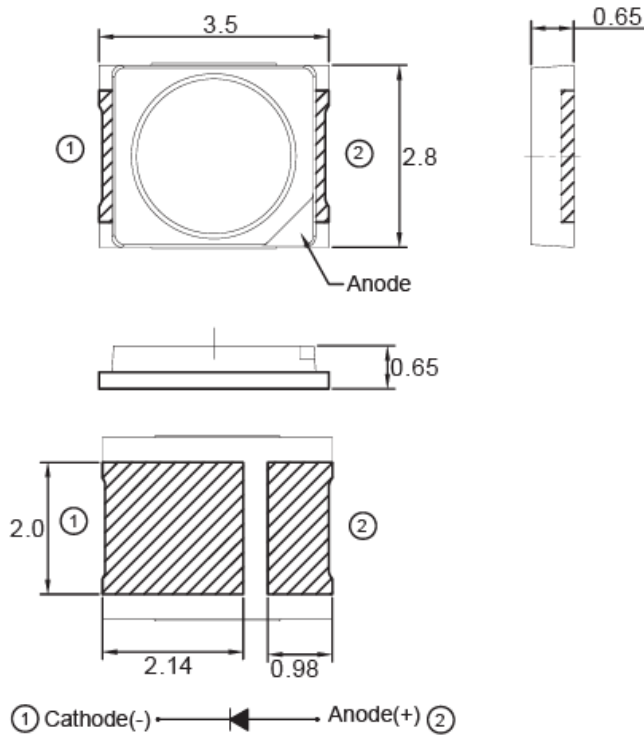

Note : 1. All dimension are in millimeter tolerance is  $\pm 0.2$ mm unless otherwise noted.  
 2. Specifications are subject to change without notice.

## Recommended Soldering Pad Dimensions

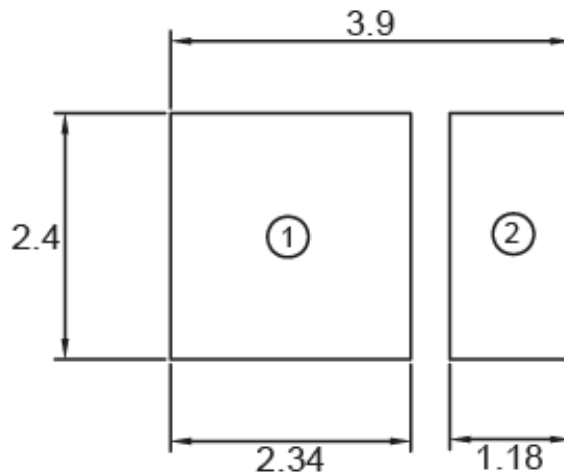

Note : The tolerances unless mentioned is  $\pm 0.1$ mm, Unit=mm.

## Absolute Maximum Ratings at Ta=25° C

Parameter	Symbol	Ratings	UNIT
Forward Current	$I_F$	60	mA
Peak vorward current Duty1/10@10KHz	$I_{FP}$	100	mA
Power Dissipation	PD	246	mW
Reverse Current(VR=5V)	$I_r$	50	$\mu$ A
Electrostatic Discharge	ESD	500	V
Operating Temperature	$T_{opr}$	-40 ~ +85	°C
Storage Temperature	$T_{stg}$	-40 ~ +100	°C

## Typical Electrical & Optical Characteristics (Ta=25° C)

Parameter	Symbol	Min.	Typ.	Max.	Unit	Condition
Luminous Intensity	$I_v$	6	9	---	lm	IF=60mA
Dominant Wavelength	$\lambda_D$	495	---	507	nm	IF=60mA
Spevctral Line Half Width	$\Delta\lambda$	---	30	---	nm	IF=60mA
Forward Voltage	VF	3.4	---	4.1	V	IF=60mA
Viewing Angle	2 $\theta$ 1/2	---	120	---	deg	IF=60mA

Note : 1. The forward voltage data did not including  $\pm 0.1V$  testing tolerance.  
 2. The luminous intensity data did not including  $\pm 15\%$  testing tolerance.  
 3. The dominant wavelength data did not including  $\pm 1nm$  testing tolerance

## Luminous Intensity Classification

BIN CODE	Iv (lm) at 60mA	
	Min.	Max.
F6	6	7
F7	7	8
F8	8	9
F9	9	10
F10	10	11
F11	11	12
F12	12	13

## Dominant Wavelength Classification

BIN CODE	$\lambda_D$ (nm) at 60mA	
	Min.	Max.
1G	495	498
1H	498	501
1I	501	504
1J	504	507

## Forward Voltage Classification

BIN CODE	Vf(v) at 60mA	
	Min.	Max.
1	3.4	3.5
2	3.5	3.6
3	3.6	3.7
4	3.7	3.8
5	3.8	3.9
6	3.9	4.0
7	4.0	4.1

## Typical Electro-Optical Characteristics Curve

Fig.1 Forward current vs. Forward Voltage

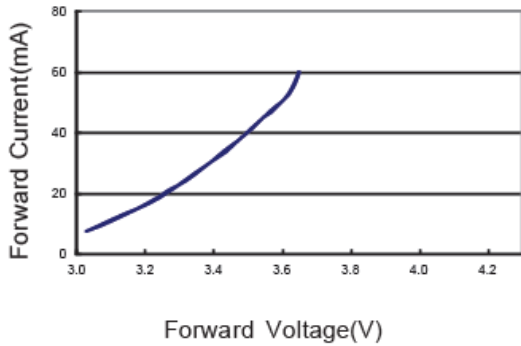

Fig.3 Forward Current VS. Soldering Temperature

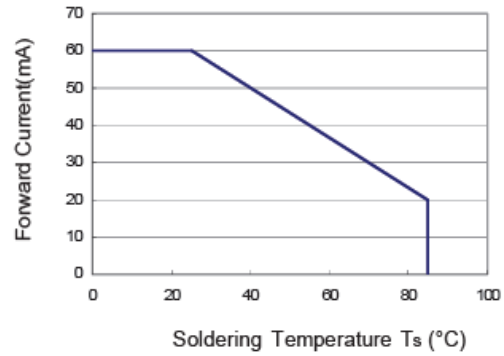

Fig.2 Forward current vs. Luminous Intensity

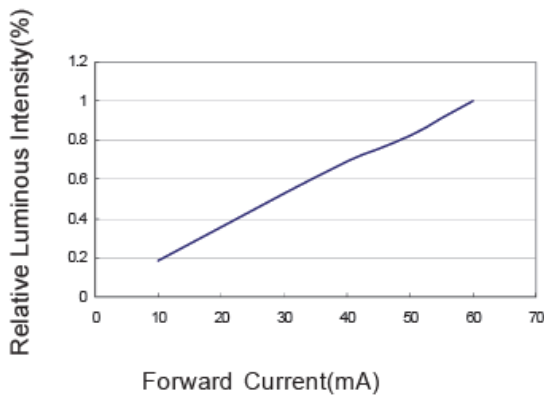

Fig.4 Luminous Intensity vs. Temperature

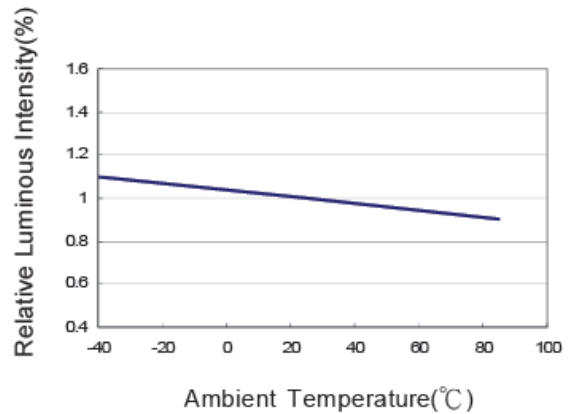

Fig.5 Relative Intensity vs. Wavelength

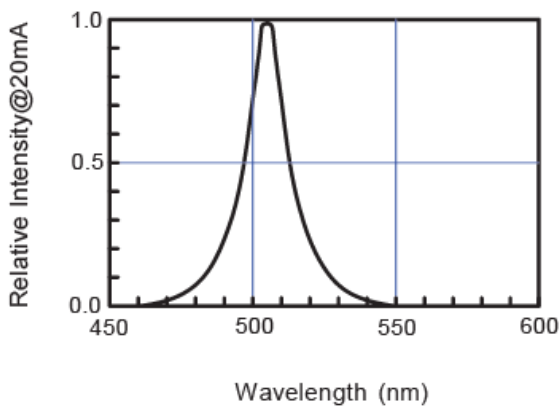
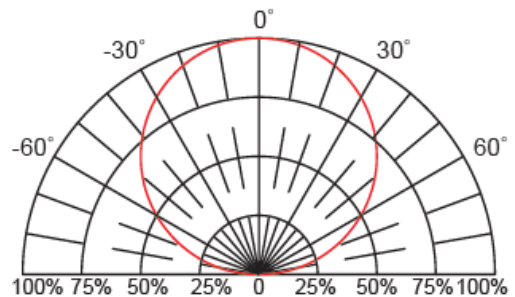
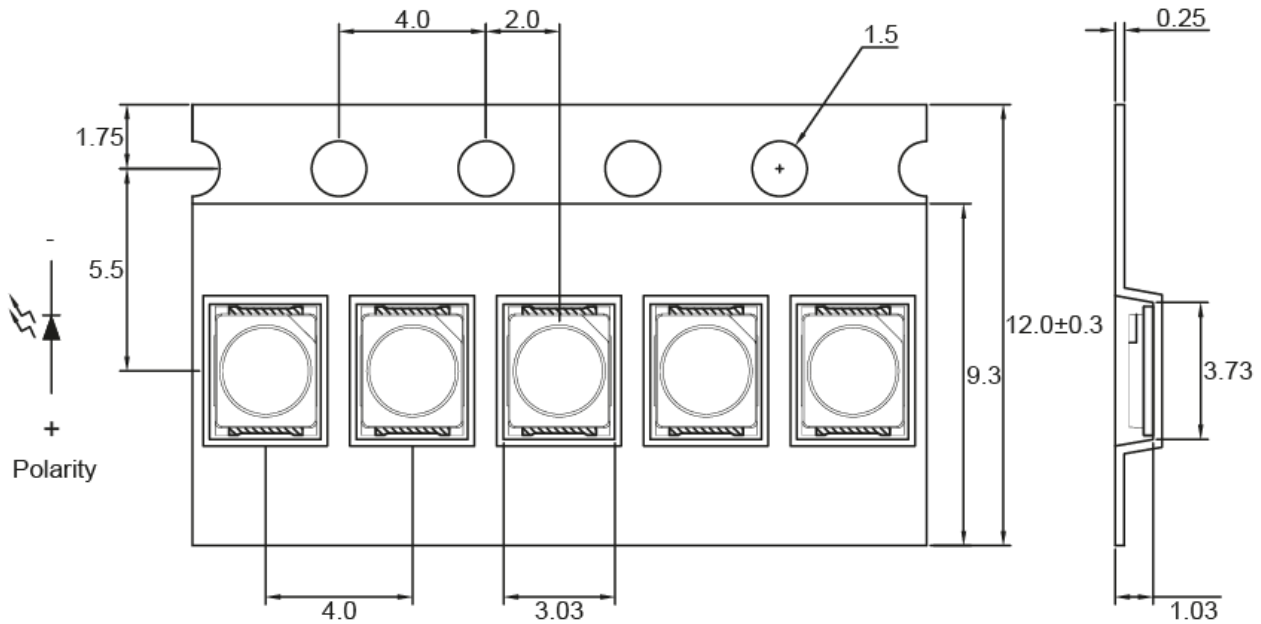

Fig.6 Directive Radiation



## Carrier Type Dimensions



Note : The tolerances unless mentioned is  $\pm 0.1$  mm, Angle  $\pm 0.5$ . Unit=mm.

## Packing Specifications

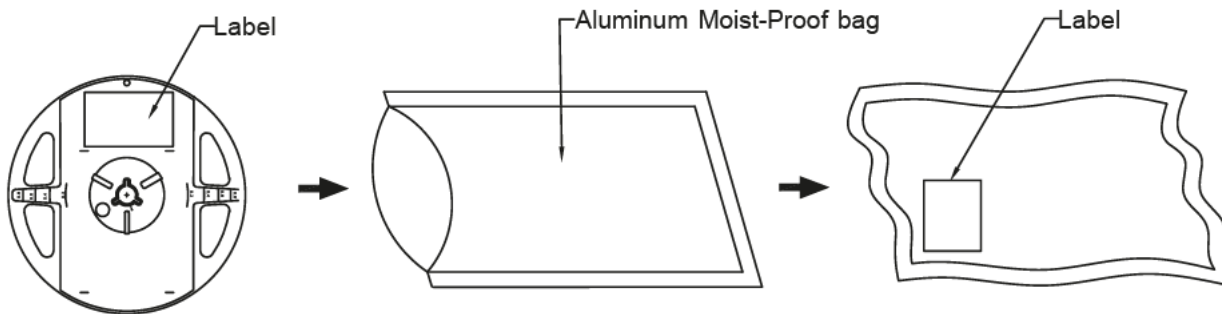

Part No.	Description	Quantity/Reel
NMOP-2835-501-60	12.0mm tape, 7" reel	2000 PCS

NMOP-2835-501-60

## Label Explanation



**N Neumüller**  
Elektronik GmbH  
www.neumueller.com

Typ / Part No. \_\_\_\_\_

Date Code / Rank \_\_\_\_\_

Menge / Quantity \_\_\_\_\_

Kunde / Customer \_\_\_\_\_

BIN : Radiant Flux

VF : Forward Voltage

## Reel Dimensions

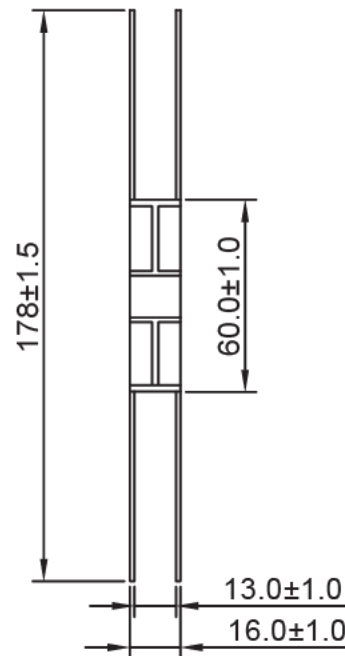
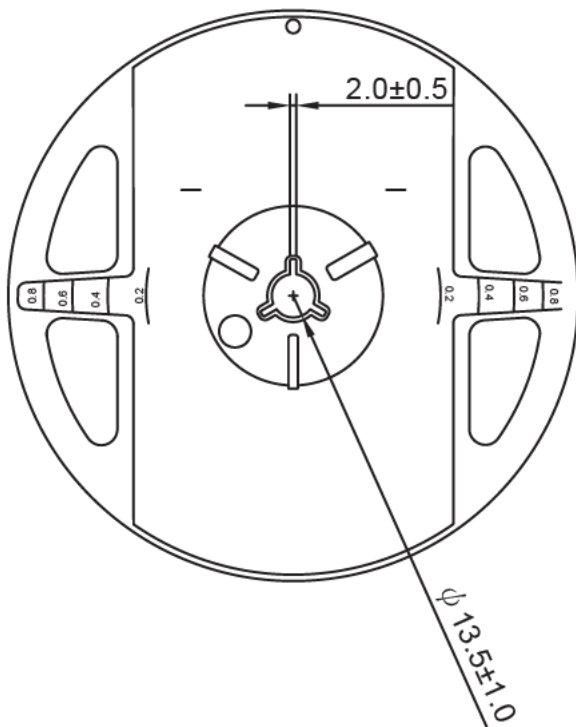

**NMOP-2835-501-60**

## Box Explanation

1. 4 BAG / INNER BOX
2. INNER BOX SIZE : L X W X H 23cm X 8.5cm x 26cm

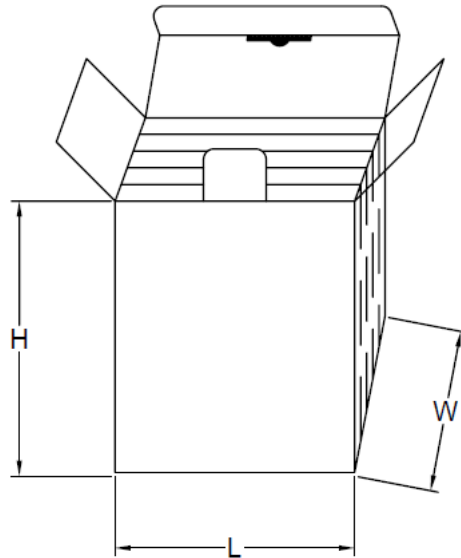

3. 10 INNER BOXES / CARTON
4. CARTON SIZE : L X W X H 58cm X 34cm x 35cm

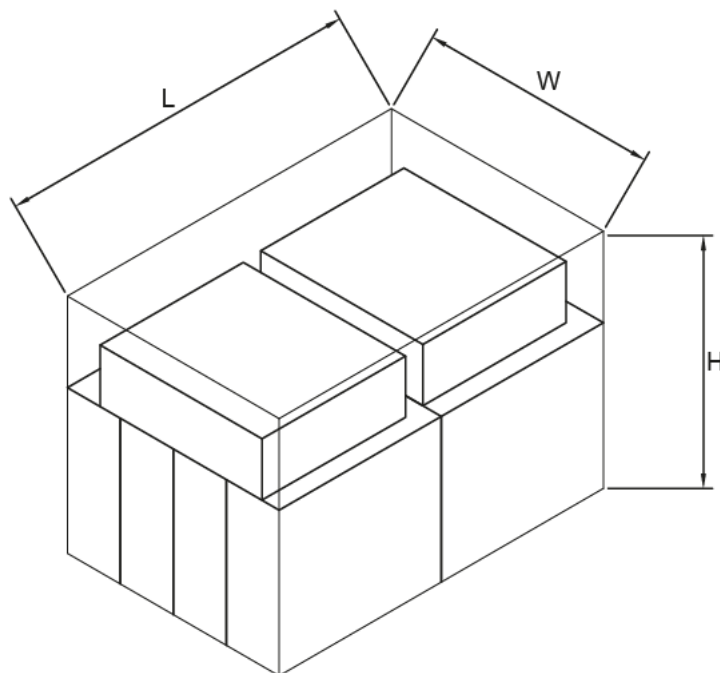



## Recommended Soldering Conditions

### 1. Hand Solder

Basic spec is  $\leq 320^{\circ}\text{C}$  3 Sec one time only

### 2. PB-Free Reflow Solder

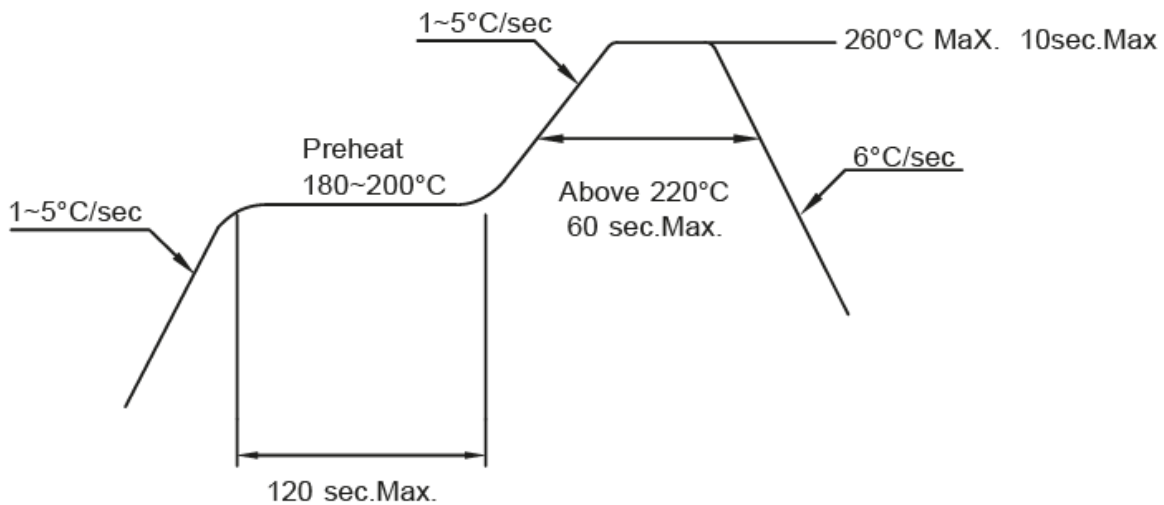

- Note:
1. Reflow soldering should not be done more than two times.
  2. When soldering, do not put stress on the LEDs during heating.
  3. After soldering, do not warp the circuit board.

## Precautions For Use:

### Storage time:

1. Calculated shelf life before opening is 12 months at  $< 30^{\circ}\text{C}$  and  $< 90\%$  relative humidity (RH)
2. After bag is opened, devices which will be subjected to reflow soldering or other high temperature processes must be
  - a) Assembled within 168 hours in an environment of  $\leq 30^{\circ}\text{C}$  / 60% RH, or
  - b) Stored at ambient of 10% RH or less
3. Devices are required baking before assembly if:
  - a) Humidity Indicator Card reads  $>10\%$  (for level 2a -5a)  
or  $>60\%$  (for level 2) at ambient temperature  $23\pm 5^{\circ}\text{C}$
  - b) 2.a) or 2.b) doesn't meet
4. If baking is required, devices should be baked for  $>24$  hours at  $60\pm 5^{\circ}\text{C}$  / 5% RH. Performing baking only once, and using the baked devices within 8 hours.

## Drive Method:

LED is a current operated device, and therefore, requires some kind of current limiting incorporated into the driver circuit. This current limiting typically takes the form of a current limiting resistor placed in series with the LED. Consider worst case voltage variations than could occur across the current limiting resistor. The forward current should not be allowed to change by more than 40% of its desired value.

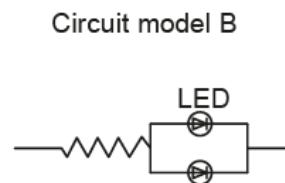
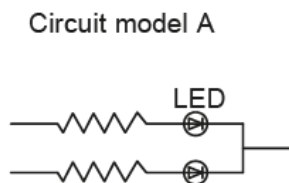

A) Recommended circuit.

(B) The difference of brightness between LED could be found due to the VF-IF characteristics of LED.

## Cleaning

Use alcohol-based cleaning solvents such as isopropyl alcohol to clean the LED.

## ESD(Electrostatic Discharge):

Static Electricity or power surge will damage the LED. Use of a conductive wrist band or anti-electrostatic glove is recommended when handling these LED. All devices, equipment and machinery must be properly grounded.

## Reliability Test:

Classification	Test Item	Test Condition	Sample Size
Endurance Test	Operating Life Test	1. Ta=25°C 2. If=60mA 3. t=1000 hrs (-24hrs,+72hrs)	22
	High Temperature Storage Test	1. Ta=100°C±5°C 2. t=1000 hrs (-24hrs,+72hrs)	22
	Low Temperature Storage Test	1. Ta=-40°C±5°C 2. t=1000 hrs (-24hrs,+72hrs)	22
	High Temperature High Humidity Storage Test	1. Ta=85°C 2. RH=85% 3. t=1000hrs(-24hrs,+72hrs)	22
Environmental Test	Thermal Shock Test	1. Ta=100°C±5°C ~ -40°C±5°C 20min/ 10sec / 20min 2. total 100 cycles	22
	Temperature Cycling	1. 100°C±5°C ~ -40°C±5°C 30mins / 5mins / 30mins 2. 100 Cycles	22
	IR Reflow	1. T=260°C Max. 10sec.Max. 2. 6 Min	22