

NMOP-2835-525-60

SURFACE MOUNT LED TAPE AND REEL

Features:

1. Top view white LED.
2. white SMT package.
3. Leadframe package with individual 2 pin.
4. Wide viewing angle.
5. Soldering methods:IR reflow soldering.
6. Feature of the device:more light due to higher optical efficiency;extremely wide viewing angle; ideal for backlighting and coupling in light guide.

Descriptions:

The NMOP-2835-525-60 SMD has wide viewing angle and optimized light coupling by inter reflector,The low current requirement makes this device ideal for portable equipment or any other application where power is at a premium.

Applications:

1. LCD back light.
2. Mobile phones.
3. Indicators.
4. Switch lights.

Device Selection Guide

Part No	Material	Color	
		Emitted	Lens
NMOP-2835-525-60	InGaN	Green	Water Clear

Package Dimensions

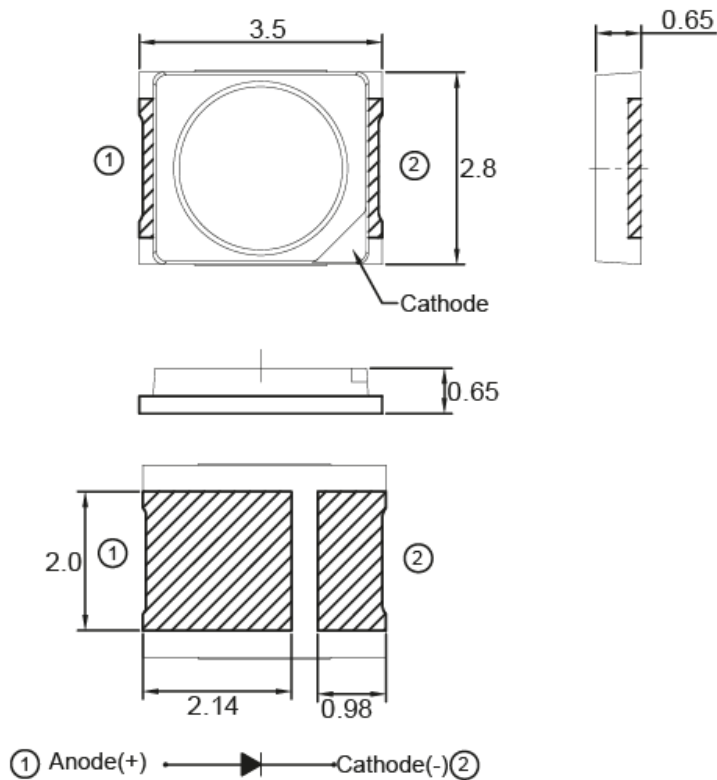

Note : 1. All dimension are in millimeter tolerance is ± 0.2 mm unless otherwise noted.
 2. Specifications are subject to change without notice.

Recommended Soldering Pad Dimensions

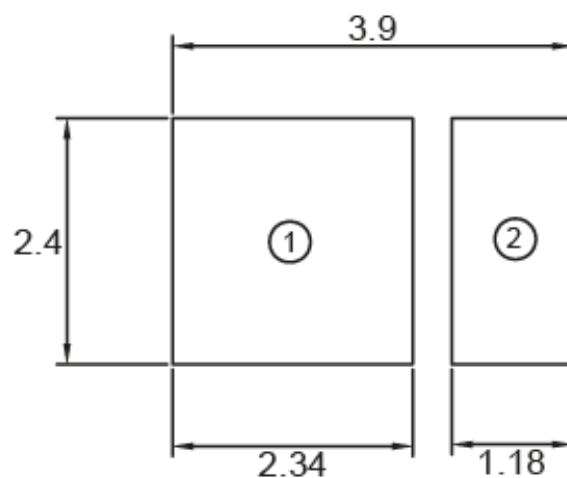

Note : The tolerances unless mentioned is ± 0.1 mm, Unit=mm.

Absolute Maximum Ratings at Ta=25° C

Parameter	Symbol	Ratings	UNIT
Forward Current	I_F	60	mA
Peak vorward current Duty1/10@10KHz	I_{FP}	100	mA
Power Dissipation	PD	246	mW
Reverse Current(VR=5V)	I_r	50	μ A
Electrostatic Discharge	ESD	500	V
Operating Temperature	T_{opr}	-40 ~ +85	°C
Storage Temperature	T_{stg}	-40 ~ +100	°C

Typical Electrical & Optical Characteristics (Ta=25° C)

Parameter	Symbol	Min.	Typ.	Max.	Unit	Condition
Luminous Intensity	I_v	11	15	---	lm	IF=60mA
Dominant Wavelength	λ_D	519	---	531	nm	IF=60mA
Spevctral Line Half Width	$\Delta\lambda$	---	36	---	nm	IF=60mA
Forward Voltage	VF	3.5	---	4.1	V	IF=60mA
Viewing Angle	2 θ 1/2	---	120	---	deg	IF=60mA

Note : 1. The forward voltage data did not including $\pm 0.1V$ testing tolerance.
 2. The luminous intensity data did not including $\pm 15\%$ testing tolerance.
 3. The dominant wavelength data did not including $\pm 1nm$ testing tolerance

Luminous Intensity Classification

BIN CODE	Iv (lm) at 60mA	
	Min.	Max.
F11D	11	13
F13D	13	15
F15D	15	17
F17D	17	18

Dominant Wavelength Classification

BIN CODE	λ_D (nm) at 60mA	
	Min.	Max.
1O	519	522
1P	522	525
1Q	525	528
1R	528	531

Vorward Voltage Classification

BIN CODE	Vf(v) at 60mA	
	Min.	Max.
1	3.5	3.6
2	3.6	3.7
3	3.7	3.8
4	3.8	3.9
5	3.9	4.0
6	4.0	4.1

Typical Electro-Optical Characteristics Curve

Fig.1 Forward current vs. Forward Voltage

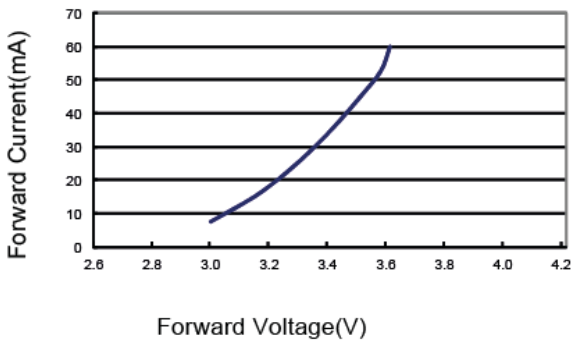

Fig.3 Max. Driving Forward Current VS. Soldering Temperature

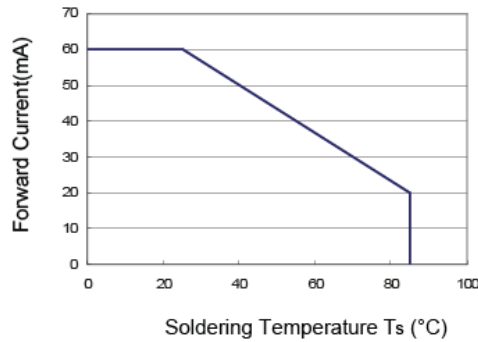

Fig.2 Forward current vs. Luminous Intensity

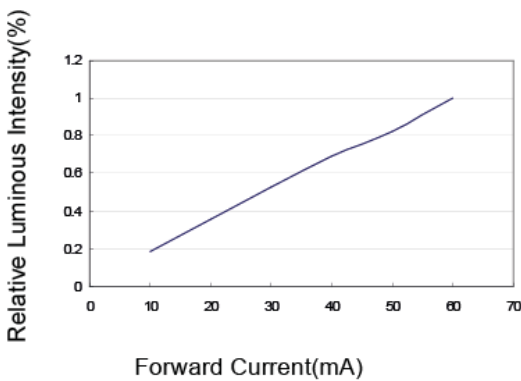

Fig.4 Luminous Intensity vs. Temperature

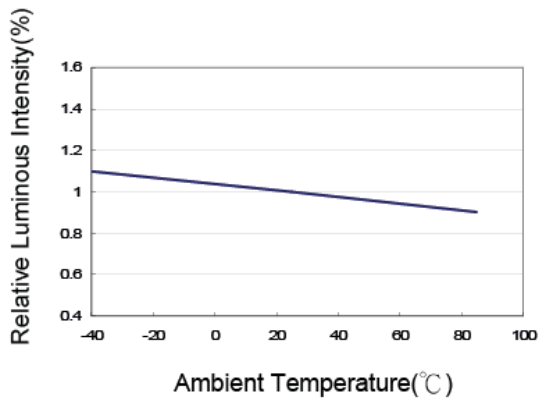

Fig.5 Relative Intensity vs. Wavelength

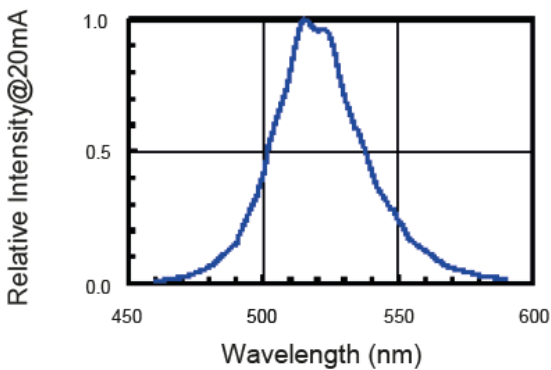
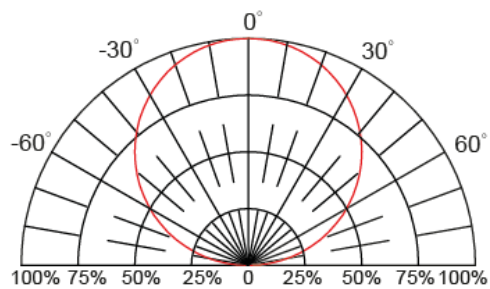
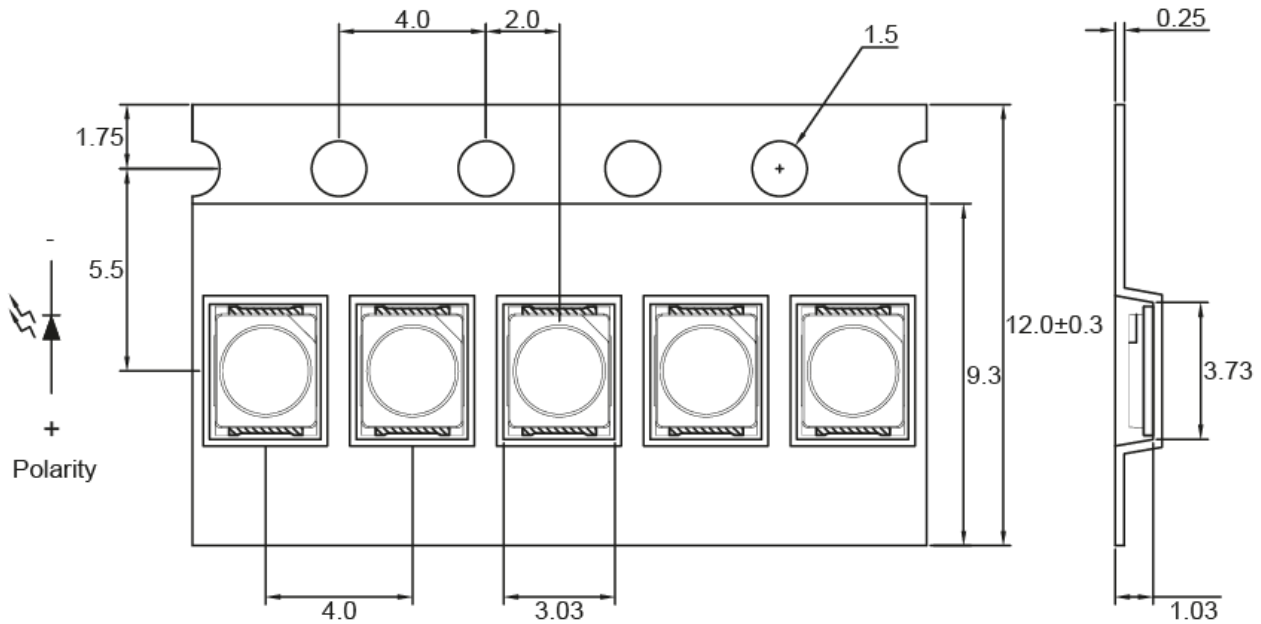

Fig.6 Directive Radiation



Carrier Type Dimensions



Note : The tolerances unless mentioned is ± 0.1 mm, Angle ± 0.5 . Unit=mm.

Packing Specifications

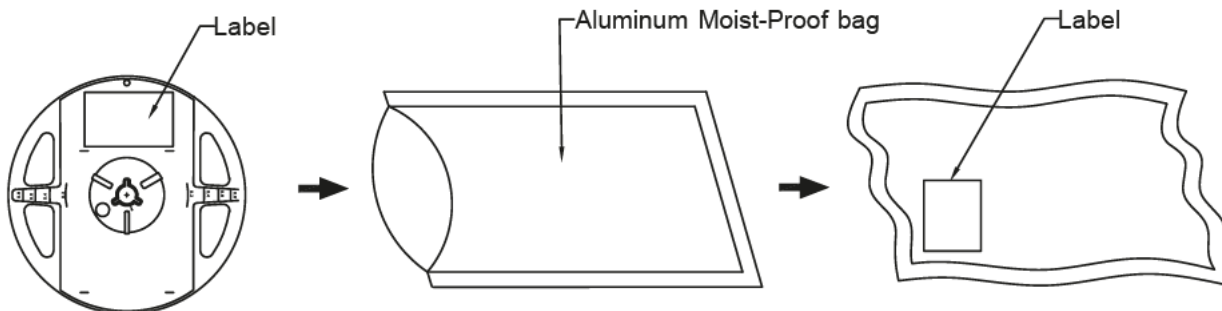

Part No.	Description	Quantity/Reel
NMOP-2835-525-60	12.0mm tape, 7" reel	2000 PCS

Label Explanation





Neumüller
 Elektronik GmbH
www.neumueller.com

Typ / Part No. _____
 Date Code / Rank _____
 Menge / Quantity _____
 Kunde / Customer _____

BIN : Radiant Flux

VF : Forward Voltage

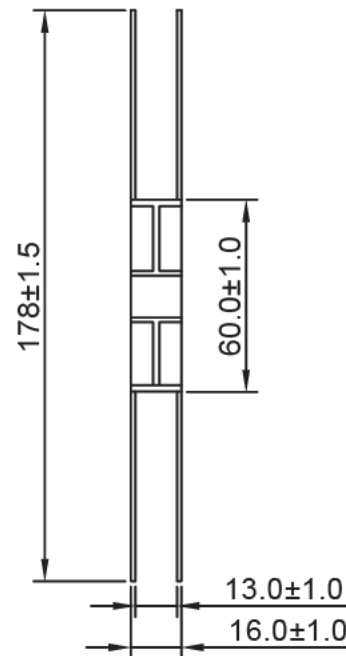
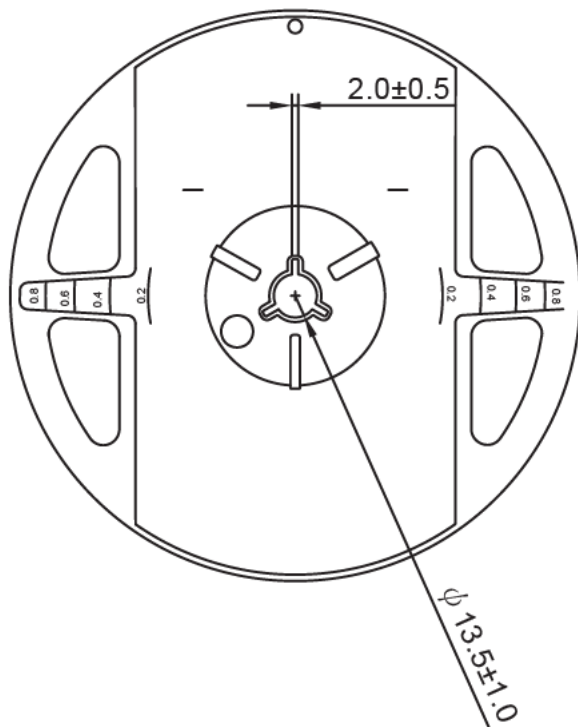
Reel Dimensions



NMOP-2835-525-60

Box Explanation

1. 4 BAG / INNER BOX
2. INNER BOX SIZE : L X W X H 23cm X 8.5cm x 26cm

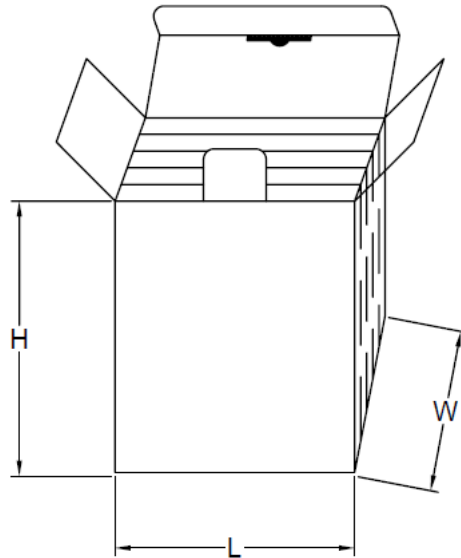

3. 10 INNER BOXES / CARTON
4. CARTON SIZE : L X W X H 58cm X 34cm x 35cm

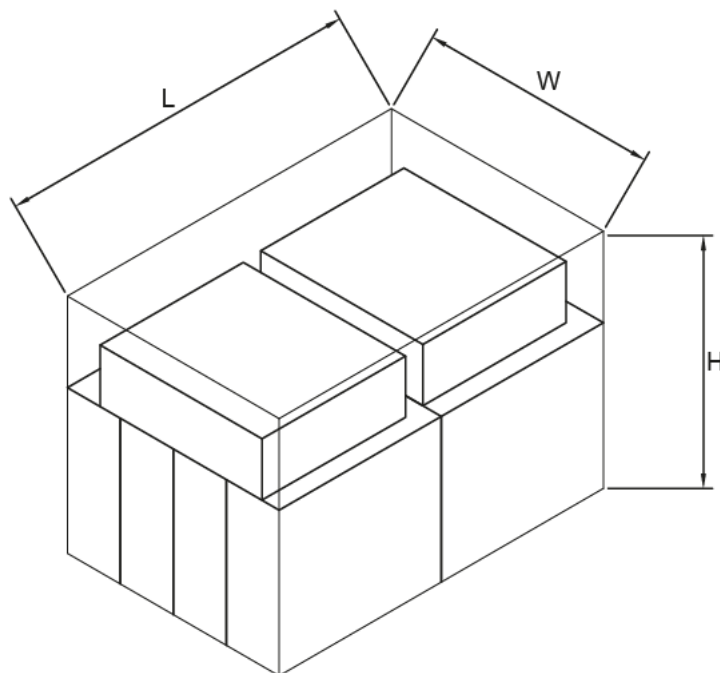

Recommended Soldering Conditions

1. Hand Solder

Basic spec is $\leq 320^{\circ}\text{C}$ 3 Sec one time only

2. PB-Free Reflow Solder

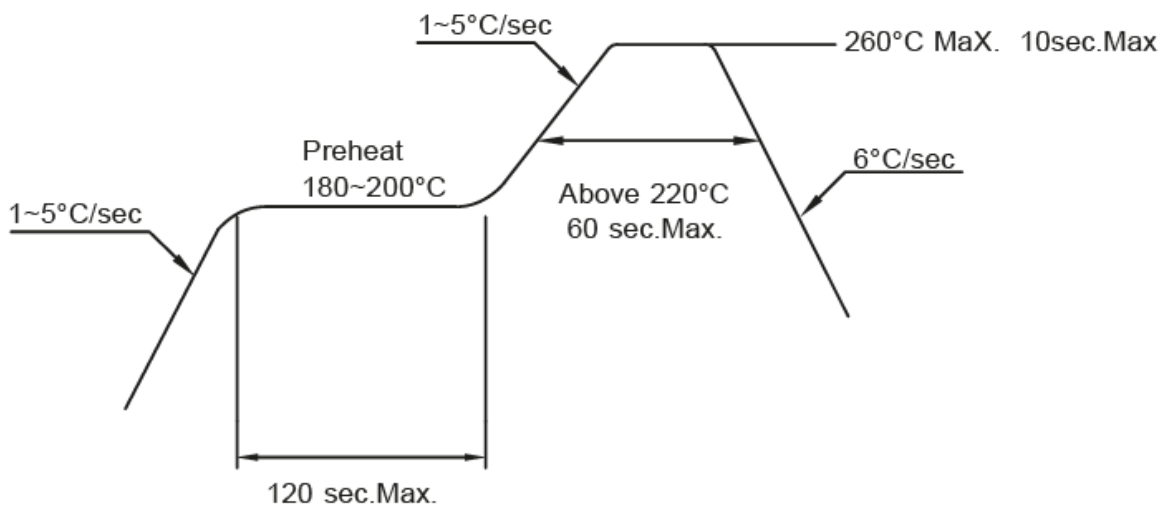

- Note:
1. Reflow soldering should not be done more than two times.
 2. When soldering, do not put stress on the LEDs during heating.
 3. After soldering, do not warp the circuit board.

Precautions For Use:

Storage time:

1. Calculated shelf life before opening is 12 months at $< 30^{\circ}\text{C}$ and $< 90\%$ relative humidity (RH)
2. After bag is opened, devices which will be subjected to reflow soldering or other high temperature processes must be
 - a) Assembled within 168 hours in an environment of $\leq 30^{\circ}\text{C}$ / 60% RH, or
 - b) Stored at ambient of 10% RH or less
3. Devices are required baking before assembly if:
 - a) Humidity Indicator Card reads $>10\%$ (for level 2a -5a)
or $>60\%$ (for level 2) at ambient temperature $23\pm 5^{\circ}\text{C}$
 - b) 2.a) or 2.b) doesn't meet
4. If baking is required, devices should be baked for >24 hours at $60\pm 5^{\circ}\text{C}$ / 5% RH. Performing baking only once, and using the baked devices within 8 hours.

Drive Method:

LED is a current operated device, and therefore, requires some kind of current limiting incorporated into the driver circuit. This current limiting typically takes the form of a current limiting resistor placed in series with the LED. Consider worst case voltage variations than could occur across the current limiting resistor. The forward current should not be allowed to change by more than 40% of its desired value.



A) Recommended circuit.

(B) The difference of brightness between LED could be found due to the VF-IF characteristics of LED.

Cleaning

Use alcohol-based cleaning solvents such as isopropyl alcohol to clean the LED.

ESD(Electrostatic Discharge):

Static Electricity or power surge will damage the LED. Use of a conductive wrist band or anti-electrostatic glove is recommended when handling these LED. All devices, equipment and machinery must be properly grounded.

Reliability Test:

Classification	Test Item	Test Condition	Sample Size
Endurance Test	Operating Life Test	1. Ta=25°C 2. If=60mA 3. t=1000 hrs (-24hrs,+72hrs)	22
	High Temperature Storage Test	1. Ta=100°C±5°C 2. t=1000 hrs (-24hrs,+72hrs)	22
	Low Temperature Storage Test	1. Ta=-40°C±5°C 2. t=1000 hrs (-24hrs,+72hrs)	22
	High Temperature High Humidity Storage Test	1. Ta=85°C 2. RH=85% 3. t=1000hrs(-24hrs,+72hrs)	22
Environmental Test	Thermal Shock Test	1. Ta=100°C±5°C ~ -40°C±5°C 20min/ 10sec / 20min 2. total 100 cycles	22
	Temperature Cycling	1. 100°C±5°C ~ -40°C±5°C 30mins / 5mins / 30mins 2. 100 Cycles	22
	IR Reflow	1. T=260°C Max. 10sec.Max. 2. 6 Min	22