

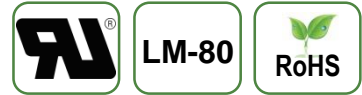
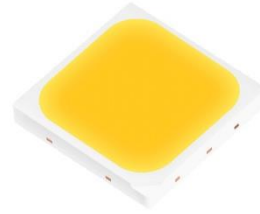

SPECIFICATION

Product : STW#L8PA-Gx

Seoul Semiconductor			Customer
Drawn by	Checked by	Approved by	Approved by
X.Y.LIU		Z.H.LEE	
2024.10.16		2024.10.16	

High-Power LED – 5050 G Series
STW#L8PA-Gx
(Cool, Neutral, Warm)

Product Brief

Description

- This White Colored surface-mount LED comes in standard package dimension.
- It has a substrate made up of a molded plastic reflector sitting on top of a lead frame.
- The die is attached within the reflector cavity and the cavity is encapsulated by silicone.
- The package design coupled with careful selection of component materials allow these products to perform with high reliability.

Features and Benefits

- High Intensity output and high luminance
- Coating Technology to Improve Reliability
- Designed for high voltage operation
- SMT solderable
- RoHS compliant
- Size : 5.0x5.0

Key Applications

- General lighting
- Architectural lighting
- LED Bulbs
- Decorative / Pathway lighting

Table of Contents

Index		
•	Product Cover	1
•	Product Brief	2
•	Table of Contents	3
•	Performance Characteristics	4
•	Characteristics Graph	6
•	Color Bin Structure	12
•	Product Nomenclature	27
•	Mechanical Dimensions	28
•	Recommended Solder Pad	29
•	Reliability Test Item & Condition	30
•	Reflow Soldering Characteristics	31
•	Emitter Tape & Reel Packaging	32
•	Handling of Silicone Resin for LEDs	34
•	Precaution For Use	35
•	Company Information	38

Product Performance & Characterization Guide

Table 1. Product Selection Guide, IF = 640mA, Tj = 25°C, RH30%

CRI min	CCT	Performance	Flux & Lm/w(typ) IF=640mA		
			G5	G7	G9
70	6500K	Flux	627.6	650.4	668.6
		lm/w	158.2	167.7	173.5
	5700K	Flux	644.0	667.3	686.0
		lm/w	162.3	172.1	178.1
	5000K	Flux	653.8	677.6	696.4
		lm/w	164.8	174.7	180.7
	4500K	Flux	659.1	683.0	702.0
		lm/w	166.1	176.1	182.2
	4000K	Flux	659.1	683.0	702.0
		lm/w	166.1	176.1	182.2
	3500K	Flux	643.9	667.3	685.9
		lm/w	162.3	172.1	178.0
	3000K	Flux	626.5	649.2	667.3
		lm/w	157.9	167.4	173.2
	2700K	Flux	607.7	629.8	647.3
		lm/w	153.2	162.4	168.0
	2200K	Flux	552.9	573.0	588.9
		lm/w	139.3	147.7	152.9
80	6500K	Flux	585.1	610.3	625.4
		lm/w	148.7	157.6	161.5
	5700K	Flux	600.9	625.7	645.2
		lm/w	152.7	161.6	166.6
	5000K	Flux	610.4	635.5	655.3
		lm/w	155.1	164.1	169.2
	4500K	Flux	615.6	640.4	660.0
		lm/w	156.4	165.4	170.5
	4000K	Flux	615.6	640.4	660.0
		lm/w	156.4	165.4	170.5
	3500K	Flux	600.2	625.7	645.3
		lm/w	152.5	161.6	166.7
	3000K	Flux	585.4	605.4	625.5
		lm/w	148.7	156.4	161.5
	2700K	Flux	565.3	590.1	605.2
		lm/w	143.6	152.4	156.3
	2200K	Flux	510.6	530.3	545.7
		lm/w	129.7	137.0	140.9

Notes :

- (1) Correlated Color Temperature is derived from the CIE 1931 Chromaticity diagram.
- (2) Seoul Semiconductor maintains a tolerance of $\pm 5\%$ on Flux and power measurements.

The luminous Flux was measured at the peak of the spatial pattern which may not be aligned with the mechanical axis of the LED package.

Product Performance & Characterization Guide

Table 2. Characteristics, $I_F=640\text{mA}$, $T_j=25^\circ\text{C}$

Parameter	Symbol	Bin	Value			Unit
			Min.	Typ.	Max.	
Forward Voltage	V_F	GxA	-	5.98	-	V
		GxB	-	6.13	-	
Forward Current	I_F	-	-	640	-	mA
CRI ^[3]	R_a	-	70	72	-	
		-	80	82	-	
Viewing Angle	$2\theta_{1/2}$	-	-	120	-	Deg.
Thermal resistance (J to S) ^[4]	$R\theta_{J-S}$	-	-	2.0	-	K/W
ESD Sensitivity(HBM)	-	-	Class 2 JESD22-A114-E			

Table 3. Absolute Maximum Ratings

Parameter	Symbol	Value	Unit
Forward Current	I_F G5	800	mA
	I_F G7	900	
	I_F G9	1000	
Junction Temperature	T_j	125	$^\circ\text{C}$
Operating Temperature	T_{opr}	-40 ~ + 85	$^\circ\text{C}$
Storage Temperature	T_{stg}	-40 ~ + 100	$^\circ\text{C}$

Notes :

- (1) Seoul Semiconductor maintains a tolerance of $\pm 5\%$ on Flux and power measurements.
 - (2) Correlated Color Temperature is derived from the CIE 1931 Chromaticity diagram.
Color coordinate : ± 0.005 , CCT $\pm 5\%$ tolerance.
 - (3) Tolerance is ± 2.0 on CRI, $\pm 0.2\text{V}$ on VF measurements.
 - (4) Thermal resistance is junction to Solder.
 - (5) The products are sensitive to static electricity and must be carefully taken when handling products
 - (6) It is recommended minimum current 5mA in order to avoid unstable brightness, and may vary depending on circuit configuration
 - (7) It is recommended to use it in the condition that the reliability is secured within the Max value.
- **Calculated performance values are for reference only.**
 - **All measurements were made under the standardized environment of Seoul Semiconductor.**

Characteristics Graph

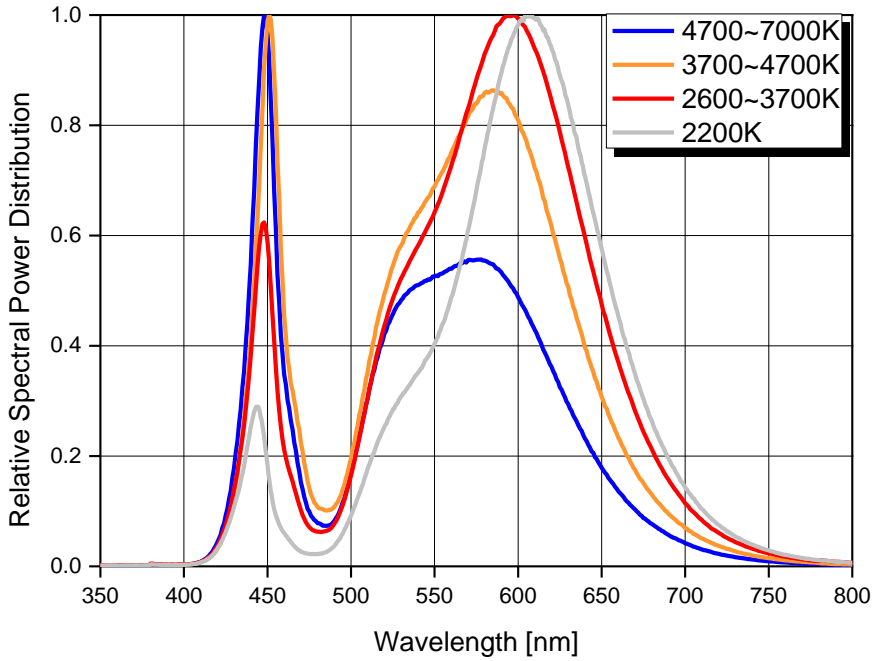
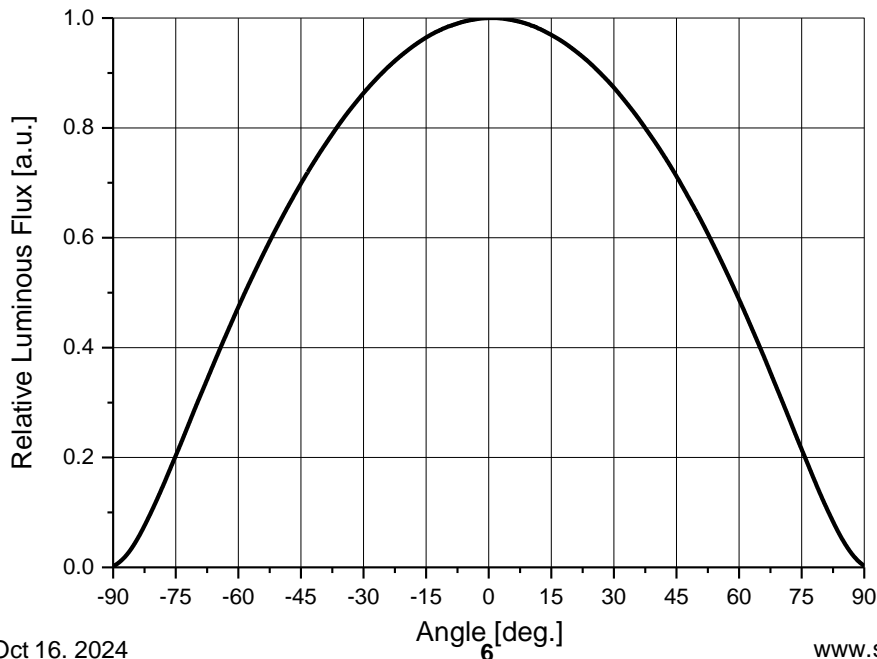
Fig 1. Color Spectrum, $T_j=25^{\circ}\text{C}$, $I_F=640\text{mA}$

Fig 2. Radiant pattern, $T_j=25^{\circ}\text{C}$, $I_F=640\text{mA}$

Characteristics Graph

Fig 3. Forward Voltage vs. Forward Current, $T_j = 25^\circ\text{C}$

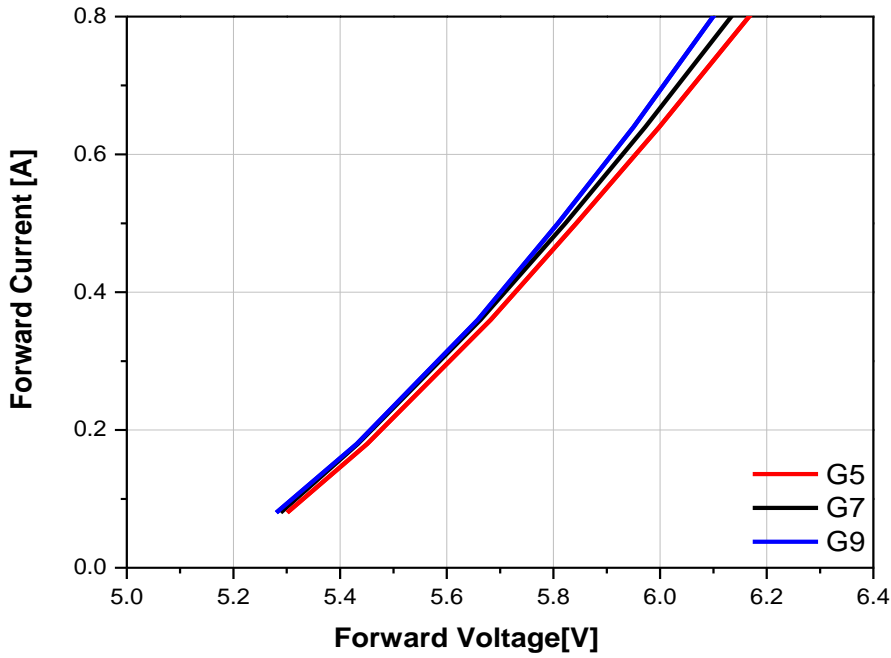
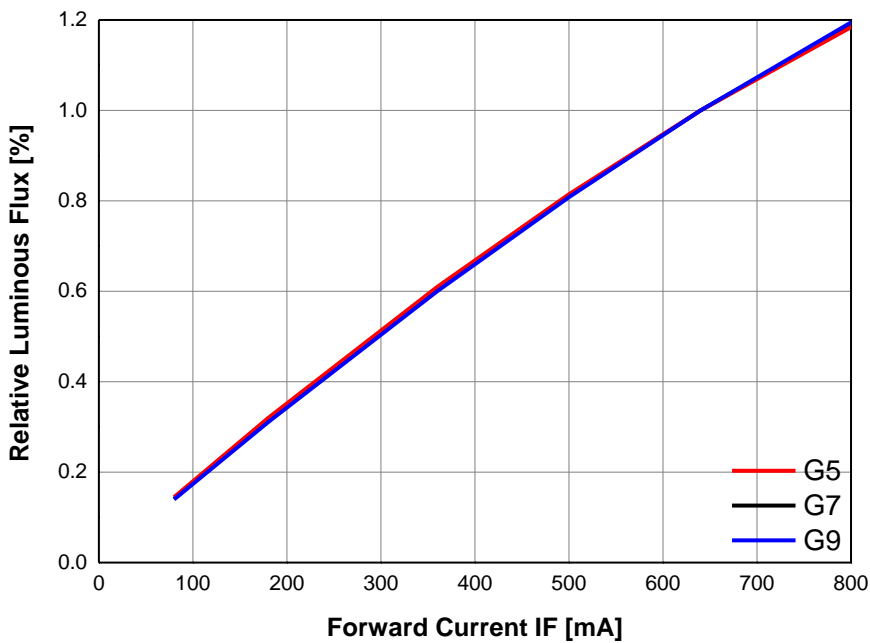

Fig 4. Forward Current vs. Relative Luminous Flux, $T_j = 25^\circ\text{C}$



- Use of less than 5mA is not recommended

Characteristics Graph

Fig 5. Forward Current vs. CIE X, Y Shift , $T_j=25^{\circ}\text{C}$

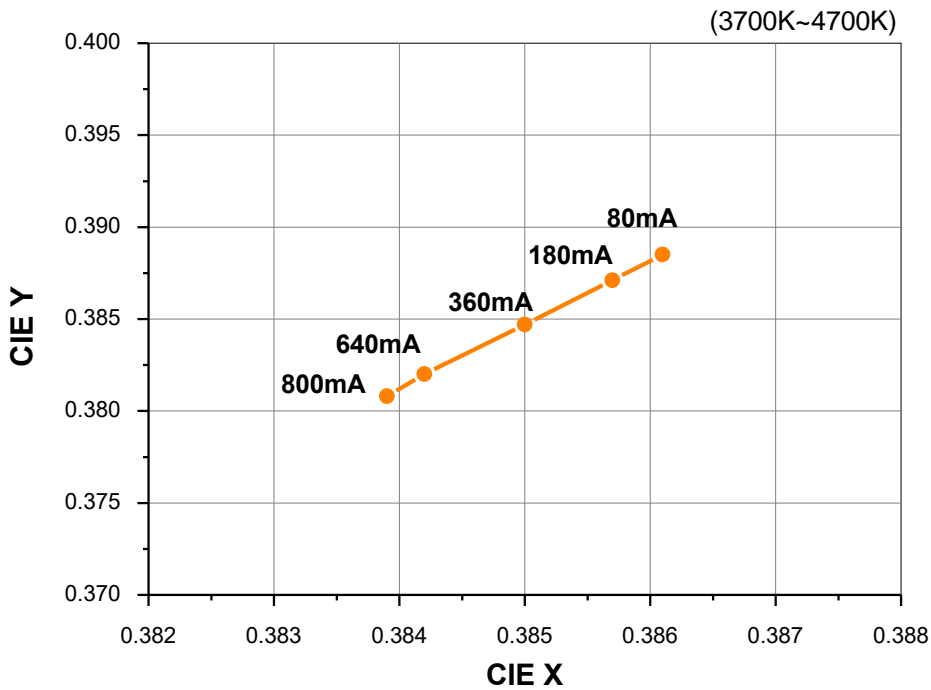
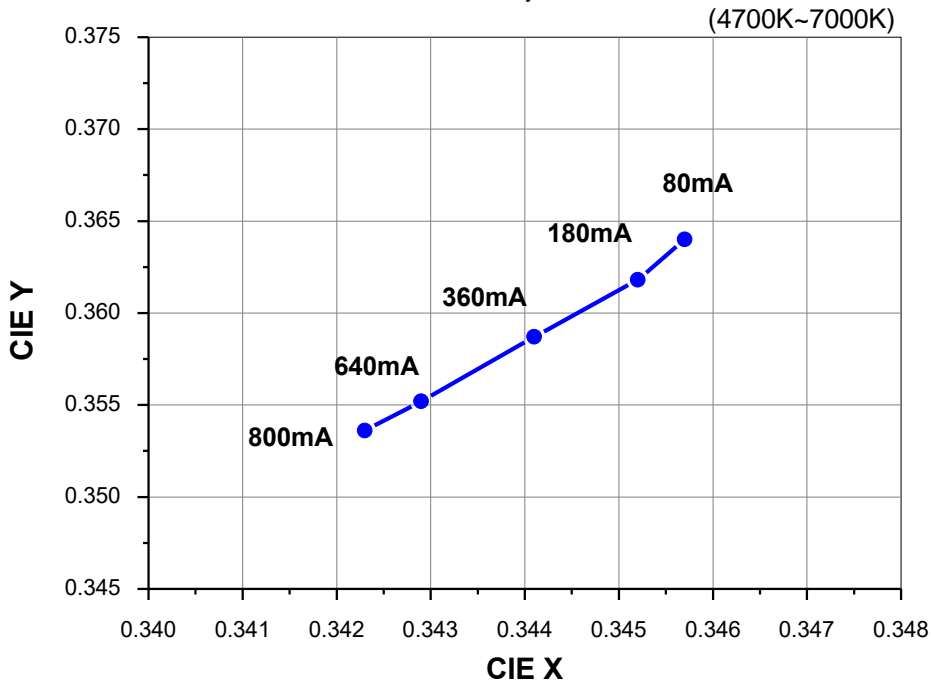

Characteristics Graph

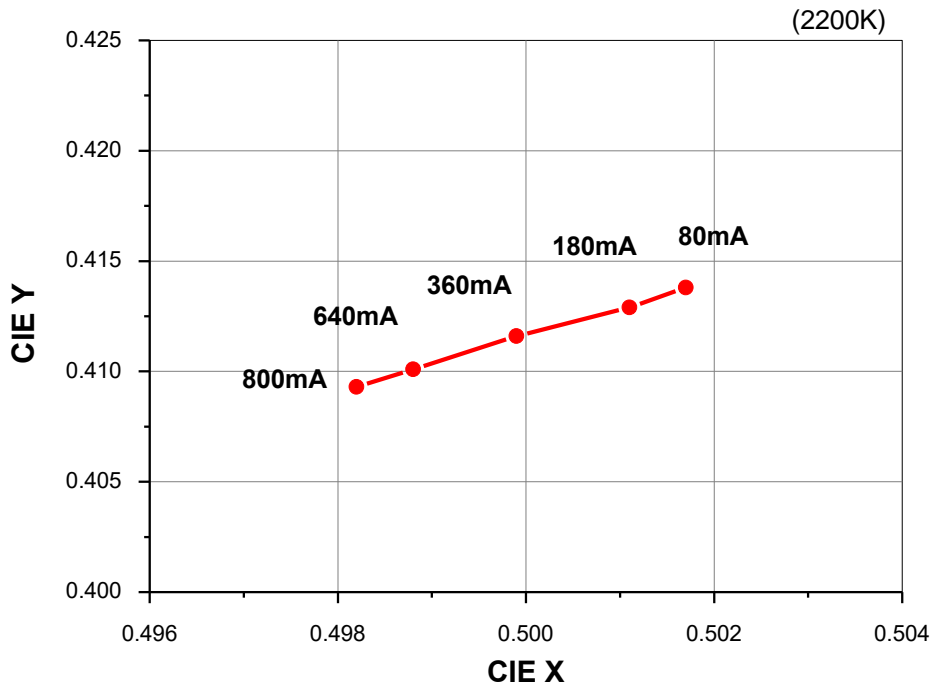
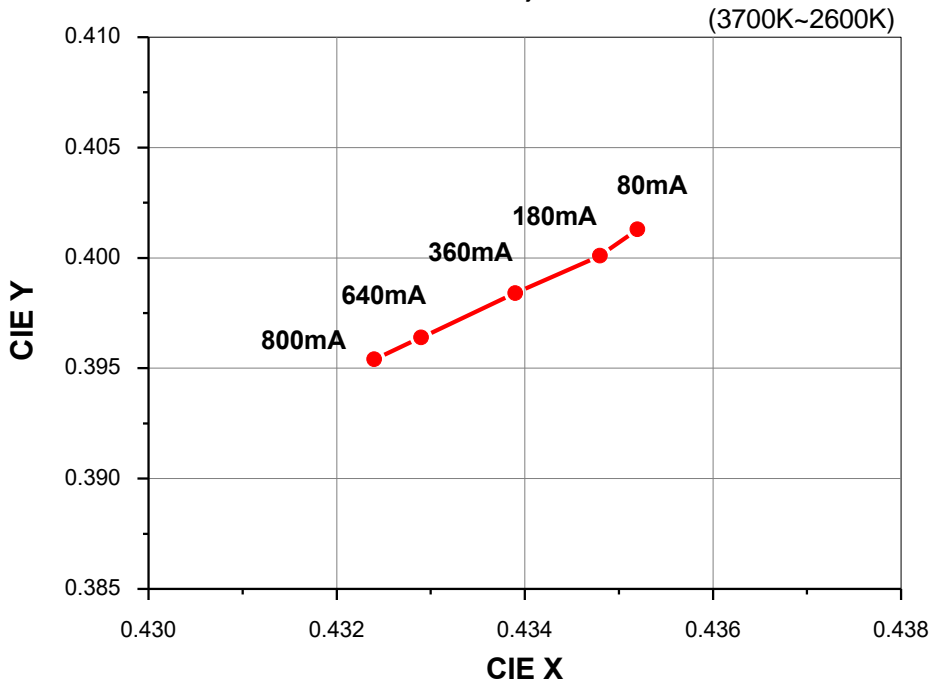
Fig 6. Forward Current vs. CIE X, Y Shift , $T_j=25^\circ\text{C}$

Characteristics Graph

Fig 7. Junction Temperature vs. Relative Luminous Flux, $I_F=640\text{mA}$

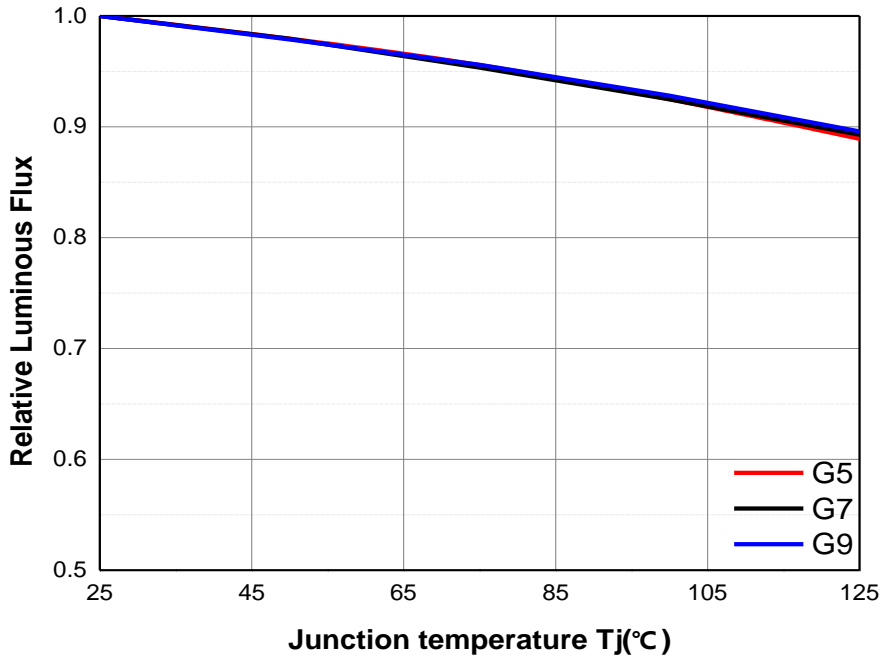
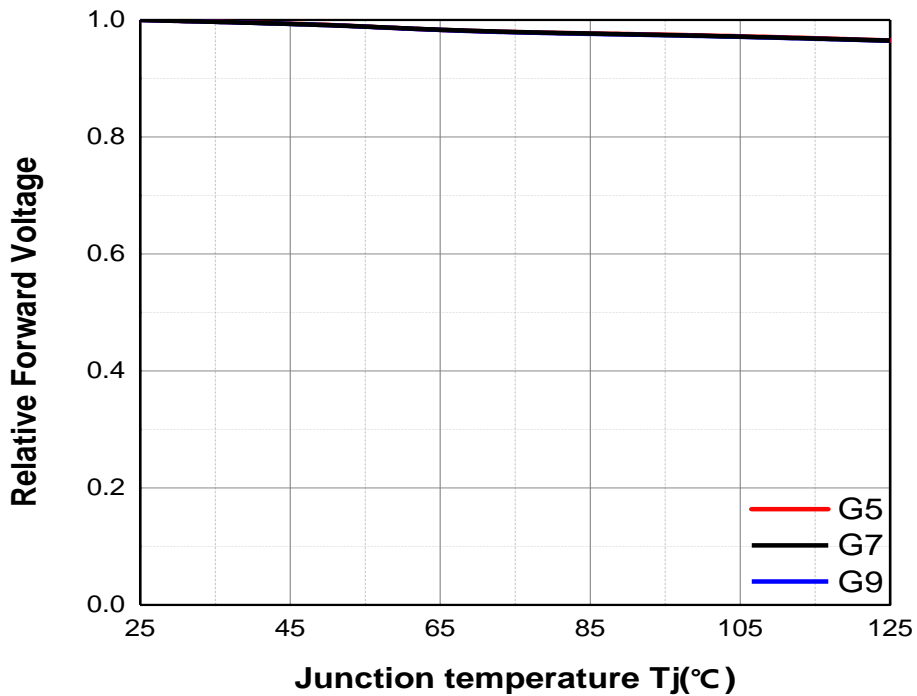
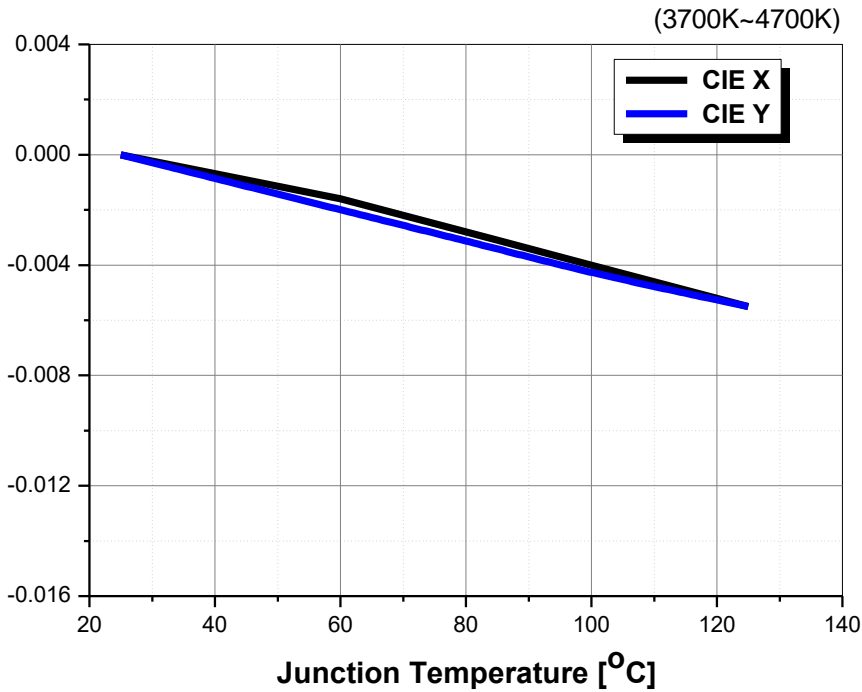
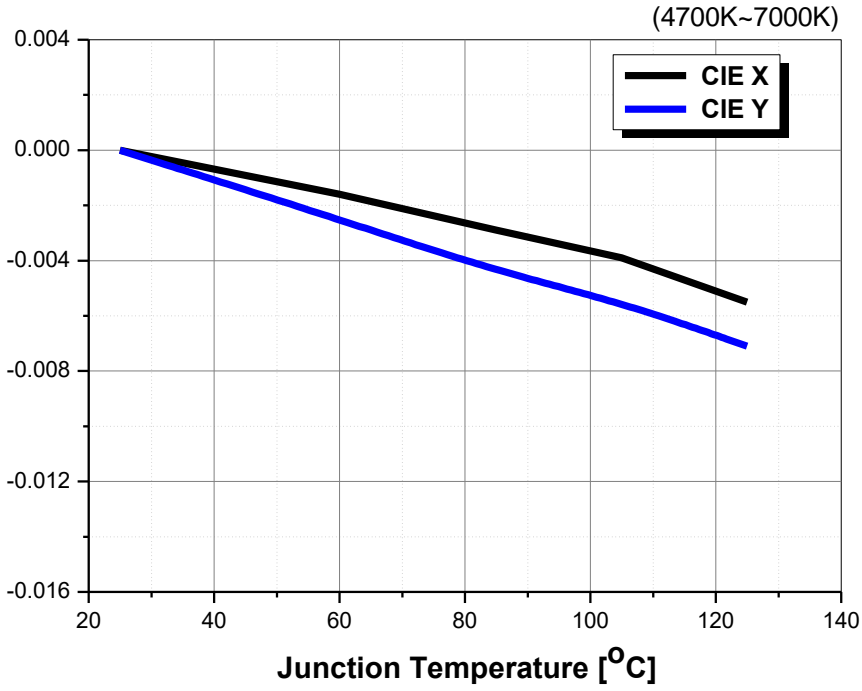

Fig 8. Junction Temperature vs. Relative Forward Voltage, $I_F=640\text{mA}$



Characteristics Graph

Fig 9. Junction Temp. vs. CIE X, Y Shift, $I_F=640\text{mA}$



Characteristics Graph

Fig 10. Junction Temp. vs. CIE X, Y Shift, $I_F=640mA$

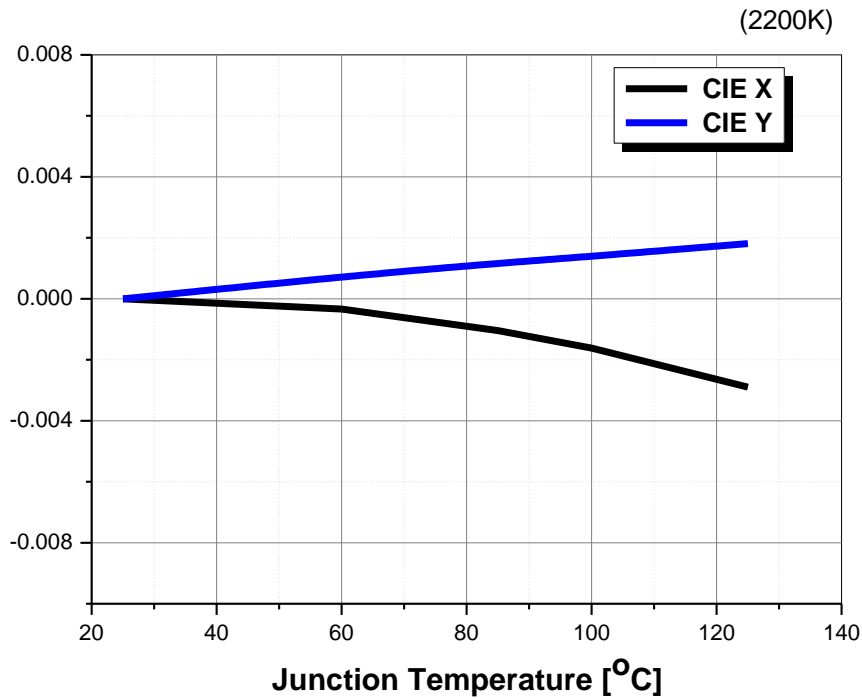
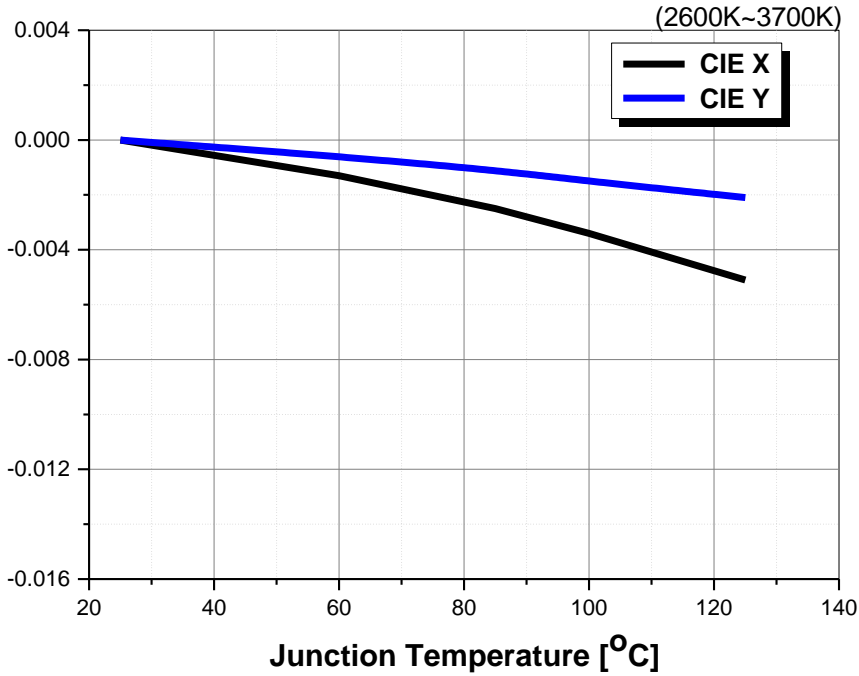

Characteristics Graph

Fig 11. Ambient Temperature vs. Maximum Forward Current, $T_{j_max} = 125^{\circ}\text{C}$

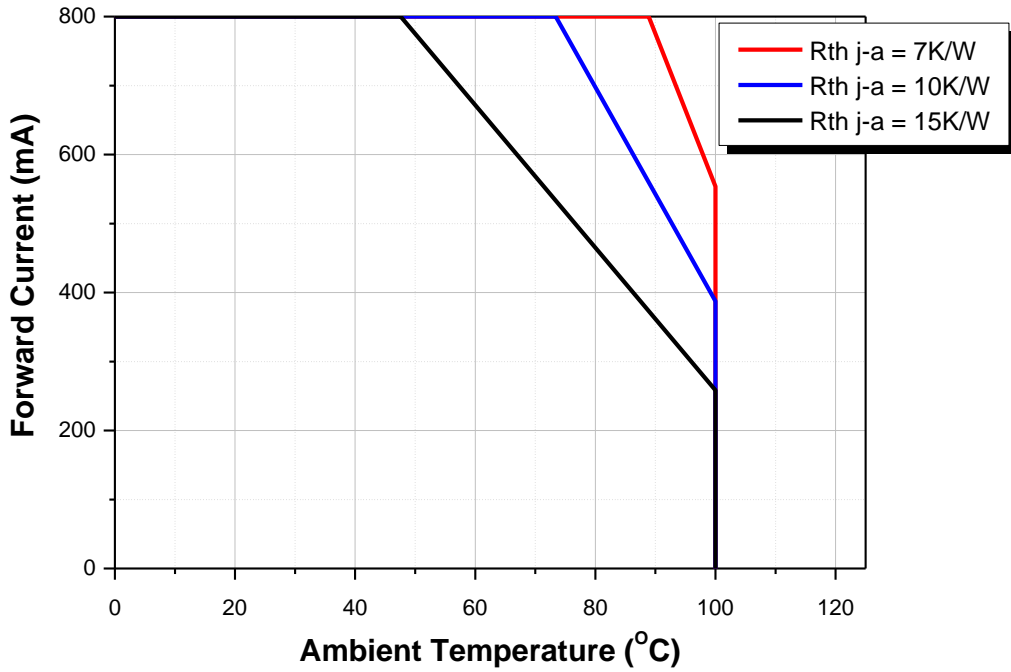

Color Bin Structure

Table 4. Available Flux Rank , $T_j=25^{\circ}\text{C}$, $I_F=640\text{mA}$

CRI	Flux Bin	7G5		7G7		7G9	
	CCT	min	max	min	max	min	max
70	6500K	605	645	630	670	645	685
	5700K	620	660	645	685	665	705
	5000K	630	670	655	695	675	715
	4500K	635	675	660	700	680	720
	4000K	635	675	660	700	680	720
	3500K	620	660	645	685	665	705
	3000K	605	645	625	665	645	685
	2700K	585	625	610	650	625	665
	2200K	530	570	550	590	565	605
CRI	Flux Bin	8G5		8G7		8G9	
	CCT	min	max	min	max	min	max
80	6500K	565	605	590	630	605	645
	5700K	580	620	605	645	625	665
	5000K	590	630	615	655	635	675
	4500K	595	635	620	660	640	680
	4000K	595	635	620	660	640	680
	3500K	580	620	605	645	625	665
	3000K	565	605	585	625	605	645
	2700K	545	585	570	610	585	625
	2200K	490	530	510	550	525	565

*** Note:**

Flux Bin #Gx : '#' means 7=CRI70,8=CRI80, 9=CRI90, N=NPR CRI 80, M=NPR CRI 90

Table 5. Available VF Rank , $T_j=25^{\circ}\text{C}$, $I_F=640\text{mA}$

Item	Unit	Bin Code	A		B	
			Min.	Max.	Min.	Max.
Forward Voltage (VF)	V	G5	6.00	6.20	6.20	6.30
		G7	5.95	6.15	6.15	6.25
		G9	5.90	6.10	6.10	6.20

*** Note:**

VF rank name will GxA,GxB : 'x' means 5 or 7 or 9 series code.

- All measurements were made under the standardized environment of Seoul Semiconductor.

Color Bin Structure

CIE Chromaticity Diagram, $T_a=25^{\circ}\text{C}$, $I_F=640\text{mA}$

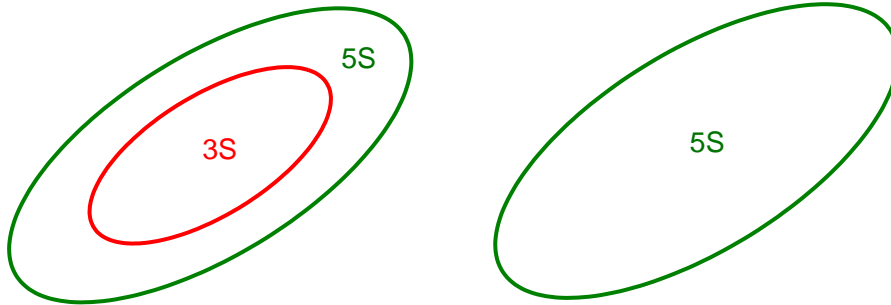

Order	Box Packing Method
xx3S	3S(3step) Single
xx4M	3S(3step) & 5S (5step) Mixing
xx5S	5S(step) Single

***Notes :**

1. xx3S Order will ship 3S
 2. xx4M Order will ship 3S & 5S Mixing(=also include 3S)
 3. xx5S Order will ship 5S(=also include 3S)
 4. Doughnut Bin will not ship alone(=Will ship with mixing bin)
- * 'xx' can be 65=6500K, 56=5600K, 50=5000K, 40=4000K, 30=3000K, 27= 2700K, 22=2200K

Color Bin Structure

CIE Chromaticity Diagram, $T_a=25^{\circ}\text{C}$, $I_F=640\text{mA}$

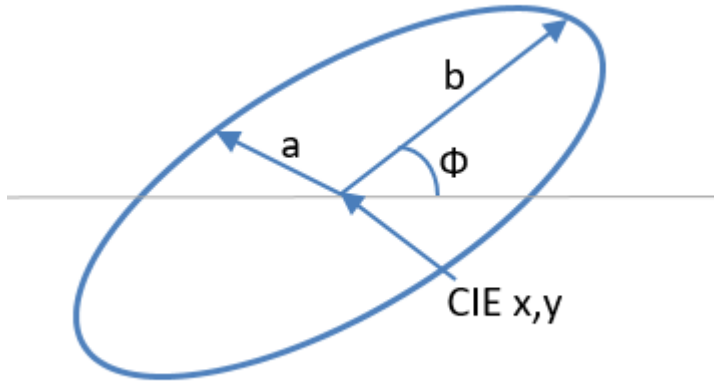

Macadam	CCT	Center Point		Major Axis	Minor Axis	Rotation Angle
	(K)	CIE x	CIE y	a	b	ϕ
3 step	2200	0.5018	0.4153	0.0086	0.0049	49
	2700	0.4578	0.4101	0.0081	0.0042	54
	3000	0.4338	0.403	0.0083	0.0040	53
	3500	0.4073	0.3917	0.0093	0.0042	54
	4000	0.3818	0.3797	0.0094	0.0040	54
	4500	0.3611	0.3658	0.0090	0.0039	55
	5000	0.3447	0.3553	0.0082	0.0035	60
	5700	0.3287	0.3417	0.0076	0.0033	59
	6500	0.3123	0.3282	0.0067	0.0029	59
5 step	2200	0.5018	0.4153	0.0144	0.0066	49
	2700	0.4578	0.4101	0.0135	0.0070	54
	3000	0.4338	0.403	0.0140	0.0068	53
	3500	0.4073	0.3917	0.0155	0.0069	54
	4000	0.3818	0.3797	0.0156	0.0068	54
	4500	0.3611	0.3658	0.0150	0.0065	55
	5000	0.3447	0.3553	0.0137	0.0058	60
	5700	0.3287	0.3417	0.0125	0.0053	59
	6500	0.3123	0.3282	0.0112	0.0048	59

Color Bin Structure

CIE Chromaticity Diagram, $T_a=25^{\circ}\text{C}$, $I_f=640\text{mA}$, $\text{CCT}=6500\text{K}$

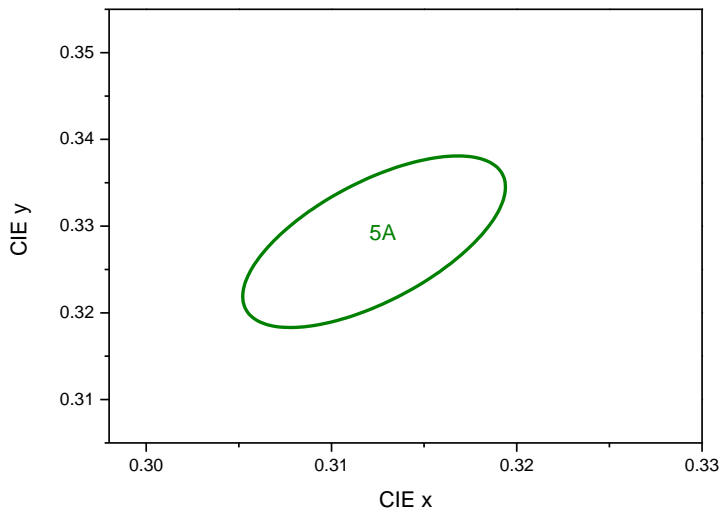
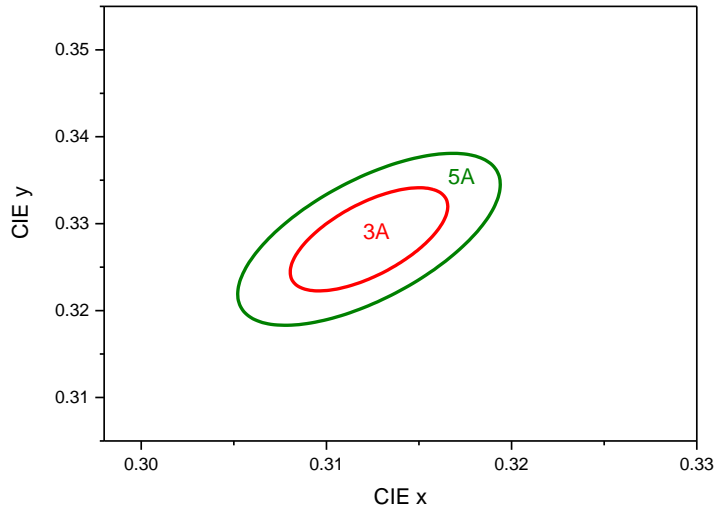

3A(3.0step)		5A (5.0Step)	
Center point	0.3123 : 0.3282	Center point	0.3123 : 0.3282
Major Axis a	0.0067	Major Axis a	0.0112
Minor Axis b	0.0029	Minor Axis b	0.0048
Ellipse Rotation Angle	59	Ellipse Rotation Angle	59

Color Bin Structure

CIE Chromaticity Diagram, $T_a=25^{\circ}\text{C}$, $I_f=640\text{mA}$, $\text{CCT}=5700\text{K}$

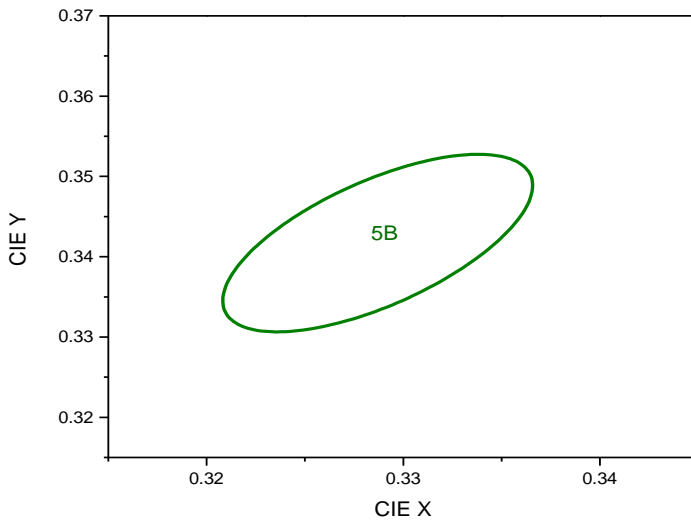
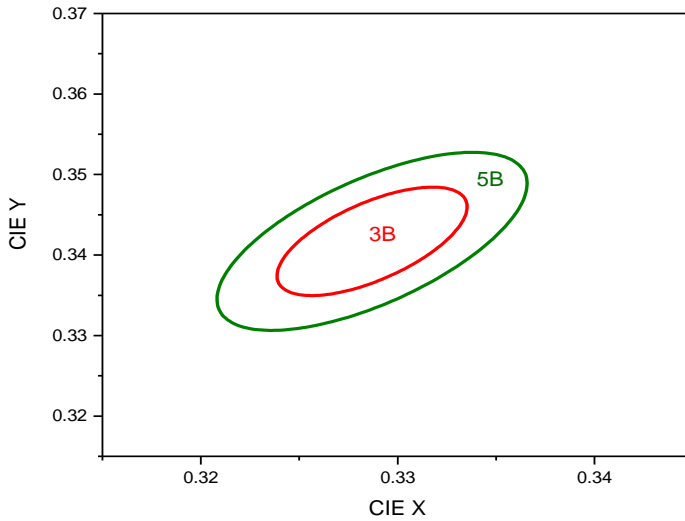

3B(3.0step)		5B (5.0Step)	
Center point	0.3287 : 0.3417	Center point	0.3287 : 0.3417
Major Axis a	0.0076	Major Axis a	0.0125
Minor Axis b	0.0033	Minor Axis b	0.0053
Ellipse Rotation Angle	59	Ellipse Rotation Angle	59

Color Bin Structure

CIE Chromaticity Diagram, $T_a=25^\circ\text{C}$, $I_f=640\text{mA}$, $\text{CCT}=5000\text{K}$

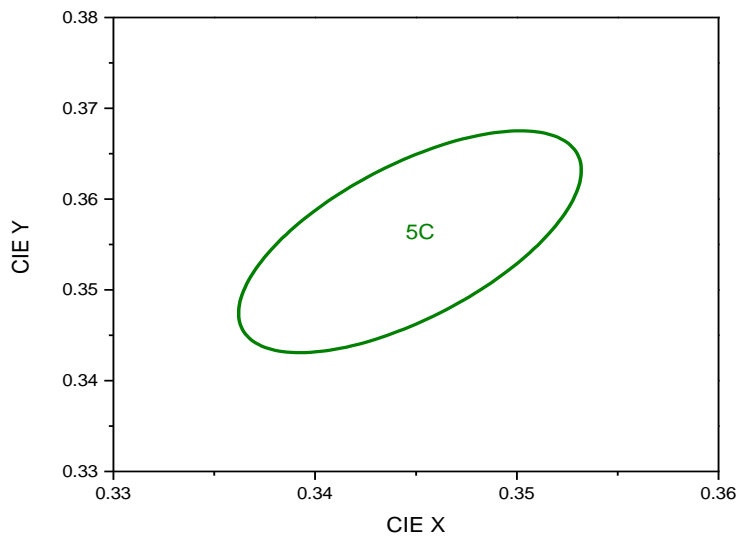
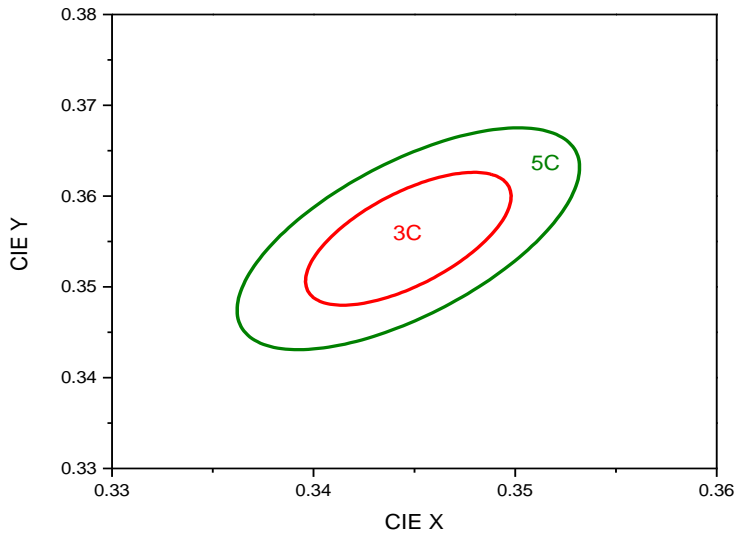

3C(3.0step)		5C (5.0Step)	
Center point	0.3447 : 0.3553	Center point	0.3447 : 0.3553
Major Axis a	0.0082	Major Axis a	0.0137
Minor Axis b	0.0035	Minor Axis b	0.0058
Ellipse Rotation Angle	60	Ellipse Rotation Angle	60

Color Bin Structure

CIE Chromaticity Diagram, $T_a=25^\circ\text{C}$, $I_f=640\text{mA}$, $\text{CCT}=4500\text{K}$

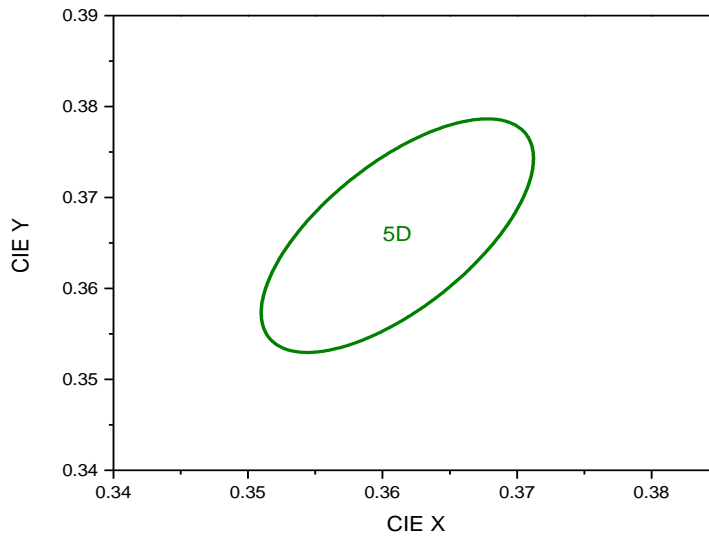
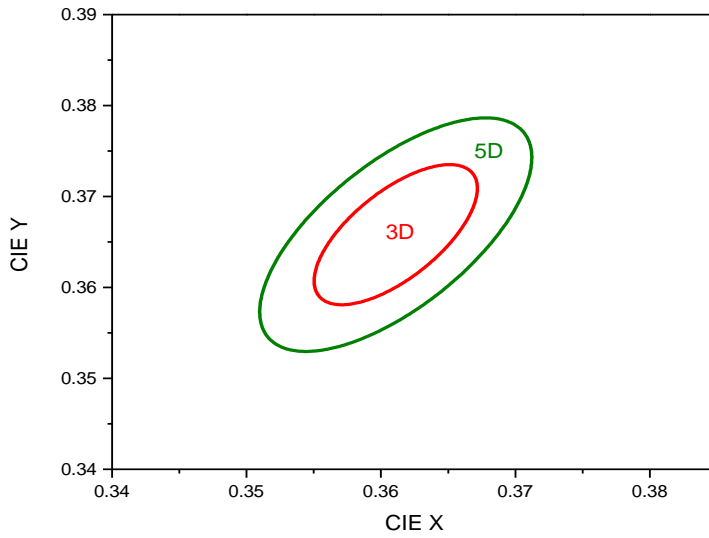

3D(3.0step)		5D (5.0Step)	
Center point	0.3611 : 0.3658	Center point	0.3611 : 0.3658
Major Axis a	0.009	Major Axis a	0.015
Minor Axis b	0.0039	Minor Axis b	0.0065
Ellipse Rotation Angle	55	Ellipse Rotation Angle	55

Color Bin Structure

CIE Chromaticity Diagram, $T_a=25^\circ\text{C}$, $I_f=640\text{mA}$, $\text{CCT}=4000\text{K}$

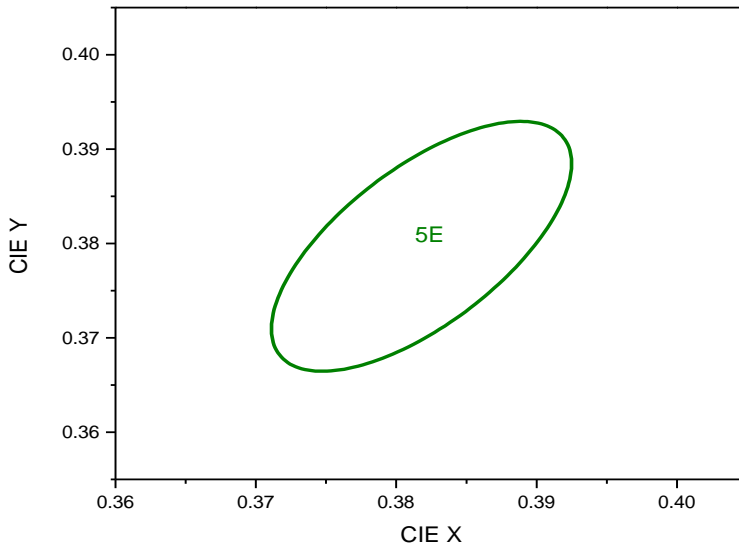
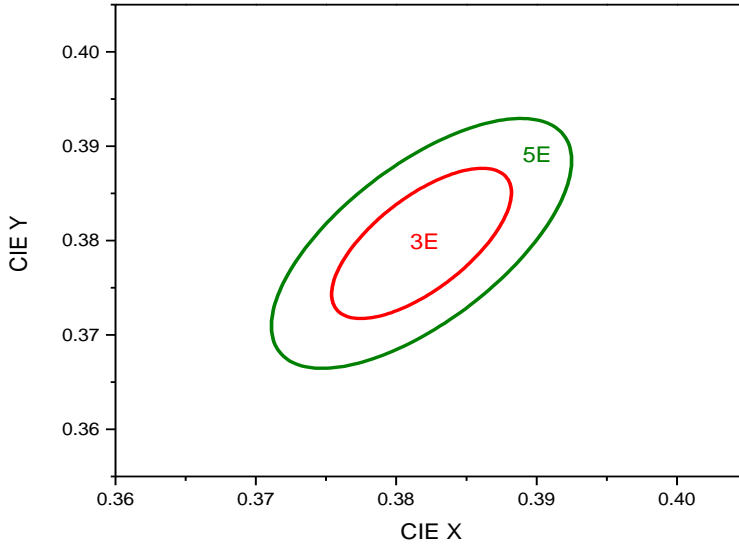

3E(3.0step)		5E (5.0Step)	
Center point	0.3818 : 0.3797	Center point	0.3818 : 0.3797
Major Axis a	0.0094	Major Axis a	0.0156
Minor Axis b	0.0040	Minor Axis b	0.0068
Ellipse Rotation Angle	54	Ellipse Rotation Angle	54

Color Bin Structure

CIE Chromaticity Diagram, $T_a=25^{\circ}\text{C}$, $I_f=640\text{mA}$, $\text{CCT}=3500\text{K}$

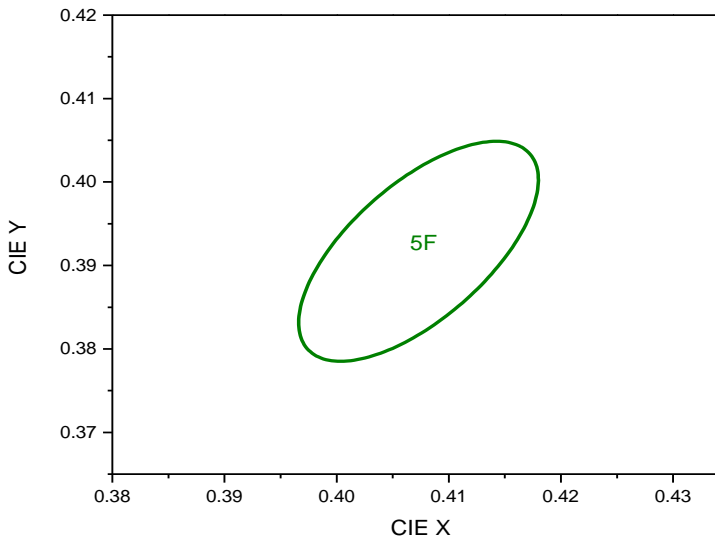
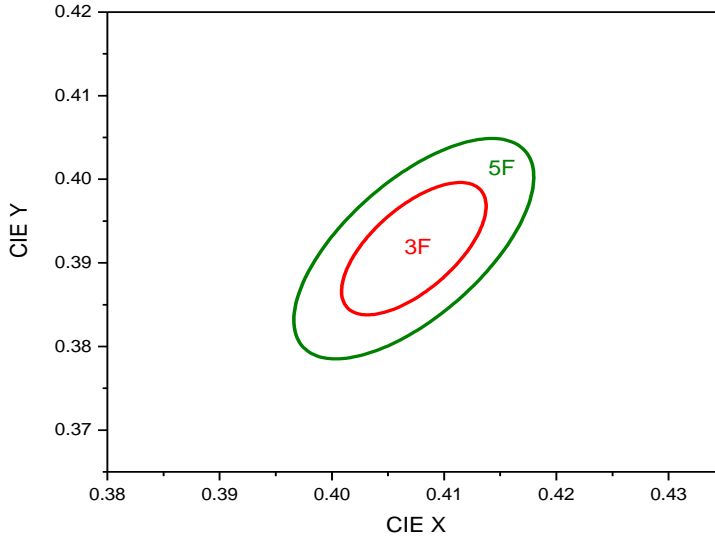

3F(3.0step)		5F (5.0Step)	
Center point	0.4073 : 0.3917	Center point	0.4073 : 0.3917
Major Axis a	0.0093	Major Axis a	0.0155
Minor Axis b	0.0042	Minor Axis b	0.0069
Ellipse Rotation Angle	54	Ellipse Rotation Angle	54

Color Bin Structure

CIE Chromaticity Diagram, $T_a=25^\circ\text{C}$, $I_f=640\text{mA}$, $\text{CCT}=3000\text{K}$

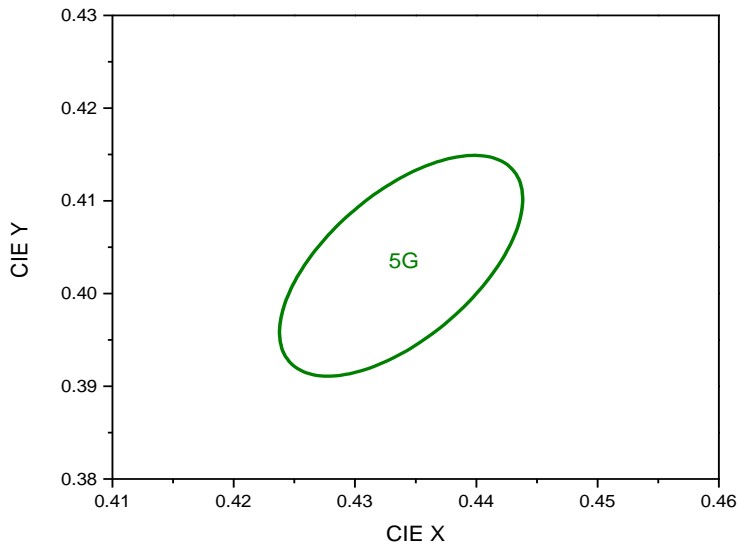
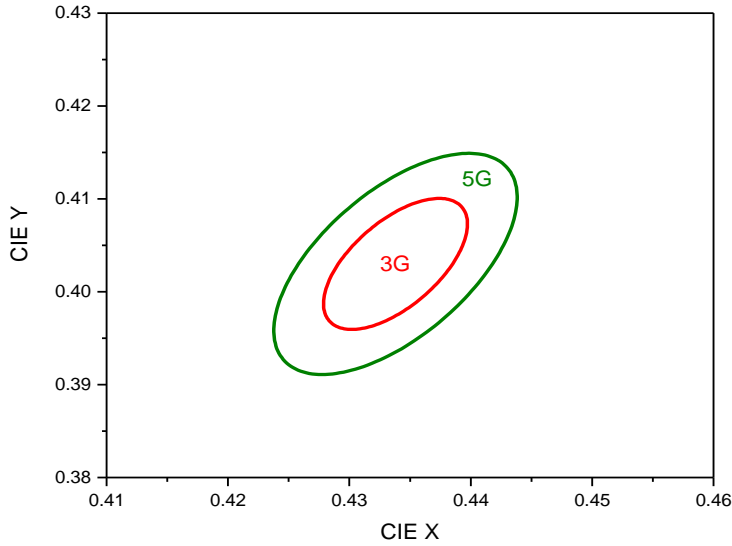

3G (3.0step)		5G (5.0Step)	
Center point	0.4338 : 0.4030	Center point	0.4338 : 0.4030
Major Axis a	0.0083	Major Axis a	0.0140
Minor Axis b	0.0040	Minor Axis b	0.0068
Ellipse Rotation Angle	53	Ellipse Rotation Angle	53

Color Bin Structure

CIE Chromaticity Diagram, $T_a=25^\circ\text{C}$, $I_f=640\text{mA}$, $\text{CCT}=2700\text{K}$

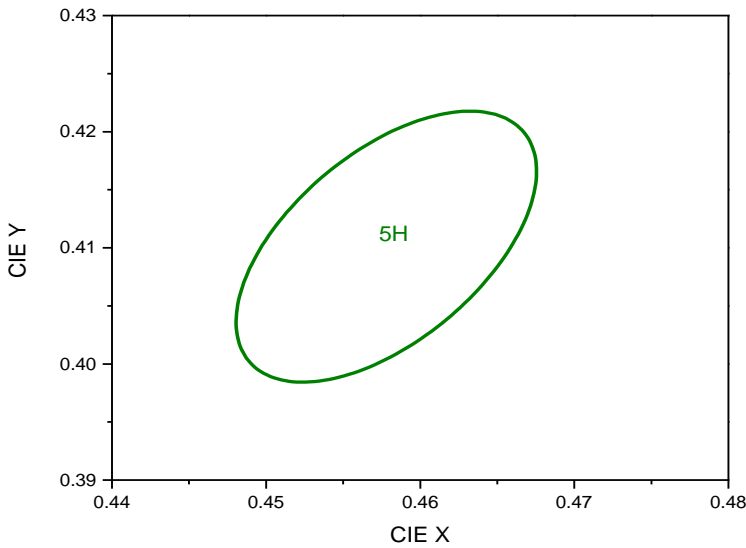
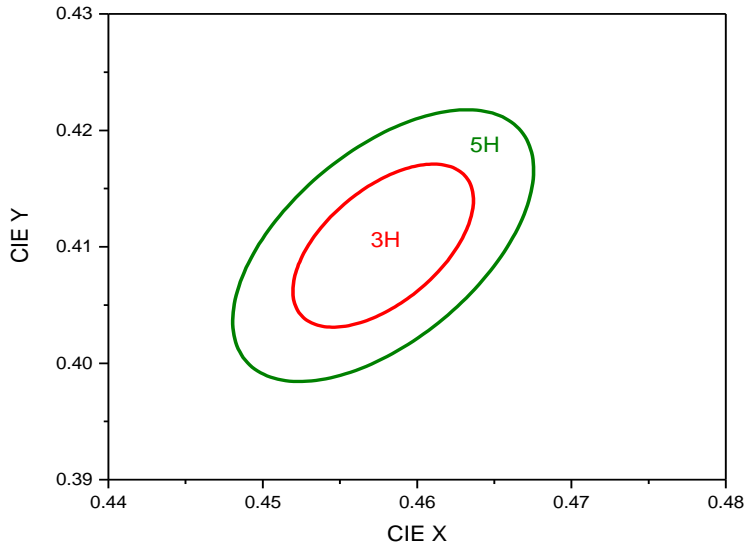

3H (3.0step)		5H (5.0Step)	
Center point	0.4578 : 0.4101	Center point	0.4578 : 0.4101
Major Axis a	0.0081	Major Axis a	0.0135
Minor Axis b	0.0042	Minor Axis b	0.0070
Ellipse Rotation Angle	54	Ellipse Rotation Angle	54

Color Bin Structure

CIE Chromaticity Diagram, $T_a=25^\circ\text{C}$, $I_f=640\text{mA}$, $\text{CCT}=2200\text{K}$

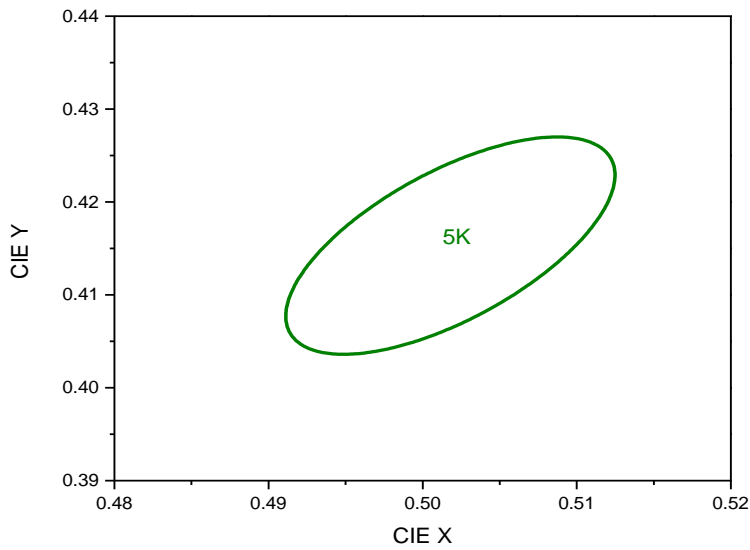
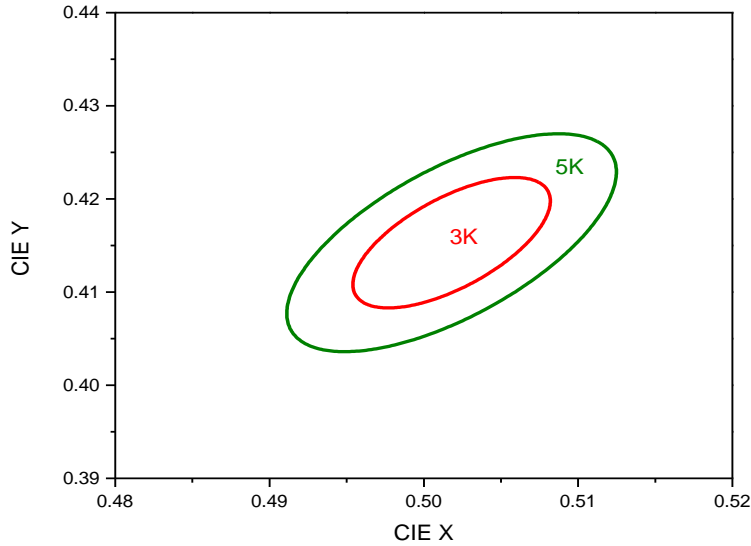

3K (3.0step)		5K (5.0Step)	
Center point	0.5018 : 0.4153	Center point	0.5018 : 0.4153
Major Axis a	0.0086	Major Axis a	0.0144
Minor Axis b	0.0040	Minor Axis b	0.0066
Ellipse Rotation Angle	49	Ellipse Rotation Angle	49

Mixing order kiting combination

Kiting Combination with xx4M

Combination	Reel	FLUX	VF	CIE	Qty
Kiting_a	Reel 1	8Gx	GxA	3S	2,000pcs
	Reel 2	8Gx	GxA	3S	2,000pcs
Kiting_b	Reel 1	8Gx	GxA	3S	2,000pcs
	Reel 2	8Gx	GxA	5S	2,000pcs
Kiting_c	Reel 1	8Gx	GxA	3S	2,000pcs
	Reel 2	8Gx	GxB	3S	2,000pcs
Kiting_d	Reel 1	8Gx	GxA	3S	2,000pcs
	Reel 2	8Gx	GxB	5S	2,000pcs

* Gx can be G5/G7/G9

Order Code Nomenclature

Table 6. Nomenclature example

S	T	W	#	L	8	P	A	-	G	x	0	0	C	1	0	N	0	0	0	a	b	b	c	c	d	d	e	e	e
X ₁	X ₂	X ₃	X ₄	X ₅	X ₆	X ₇	X ₈	X ₉	X ₁₀	X ₁₁	X ₁₂	X ₁₃	X ₁₄	X ₁₅	X ₁₆	X ₁₇	X ₁₈	X ₁₉	X ₂₀	X ₂₁	X ₂₂	X ₂₃	X ₂₄	X ₂₅	X ₂₆	X ₂₇	X ₂₈	X ₂₉	X ₃₀

Part Number Code	Value	References	Description
X ₁	S	Seoul Semiconductor	Company
X ₂	T	Top lighting	Top View LED series
X ₃	W	White	
X ₄	#	CRI	0: CRI70/ 8: CRI 80 / 9: CRI90
X ₅	L	5050	Package series
X ₆ X ₇	8P	Characteristic code	S: Series / P: Parallel
X ₈	A		Version
X ₉	-		
X ₁₀ X ₁₁	Gx	internal code	G5/G7/G9
X ₁₂ ~X ₂₀	00C10N000	internal code	
X ₂₁ X ₂₂ X ₂₃	abb	Flux Bin	a: 7=CRI70 8=CRI80, 9=CRI90 bb: G5/G7/G9
X ₂₄ X ₂₅	cc	Color Temp.	65=6500K, 57=5700K, 50=5000K, 45=4500K,40=4000K, 30=3000K, 27= 2700K,22=2200K
X ₂₆ X ₂₇	dd	step	3S: 3step single / 4M: 4step Mixing / 5S:5step single
X ₂₈ X ₂₉ X ₃₀	eee	VF Bin	GxA:G5A/G7A/G9A GxB:G5B/G7B/G9B 000: All bin

Table 7. Product Selection Table(CRI70 for example)

Reference P/N	Order code	Flux bin	CCT	Step	VF bin
STW0L8PA-Gx00C10N000	7Gx653SGxA / 7Gx655SGxA	7Gx:7G5,7G7,7G9	65:6500K	3S: 3step 5S: 5step	GxA
	7Gx573SGxA / 7Gx575SGxA	7Gx:7G5,7G7,7G9	57:5700K		GxA
	7Gx503SGxA / 7Gx505SGxA	7Gx:7G5,7G7,7G9	50:5000K		GxA
	7Gx453SGxA / 7Gx455SGxA	7Gx:7G5,7G7,7G9	45:4500K		GxA
	7Gx403SGxA / 7Gx405SGxA	7Gx:7G5,7G7,7G9	40:4000K		GxA
	7Gx353SGxA / 7Gx355SGxA	7Gx:7G5,7G7,7G9	35:3500K		GxA
	7Gx303SGxA / 7Gx305SGxA	7Gx:7G5,7G7,7G9	30:3000K		GxA
	7Gx273SGxA / 7Gx275SGxA	7Gx:7G5,7G7,7G9	27:2700K		GxA
7Gx223SGxA / 7Gx225SGxA	7Gx:7G5,7G7,7G9	22:2200K	GxA		
Reference P/N	Order code	Flux bin	CCT	Step	VF bin
STW0L8PA-Gx00C10N000	7Gx654M000	7Gx:7G5,7G7,7G9	65:6500K	4M: 4step Mixing	ALL
	7Gx574M000	7Gx:7G5,7G7,7G9	57:5700K		ALL
	7Gx504M000	7Gx:7G5,7G7,7G9	50:5000K		ALL
	7Gx454M000	7Gx:7G5,7G7,7G9	45:4500K		ALL
	7Gx404M000	7Gx:7G5,7G7,7G9	40:4000K		ALL
	7Gx354M000	7Gx:7G5,7G7,7G9	35:3500K		ALL
	7Gx304M000	7Gx:7G5,7G7,7G9	30:3000K		ALL
	7Gx274M000	7Gx:7G5,7G7,7G9	27:2700K		ALL
	7Gx224M000	7Gx:7G5,7G7,7G9	22:2200K		ALL

Mechanical Dimensions

< Top View >

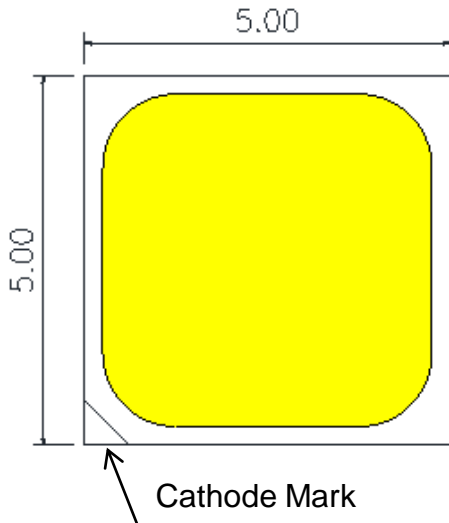

< Bottom View >

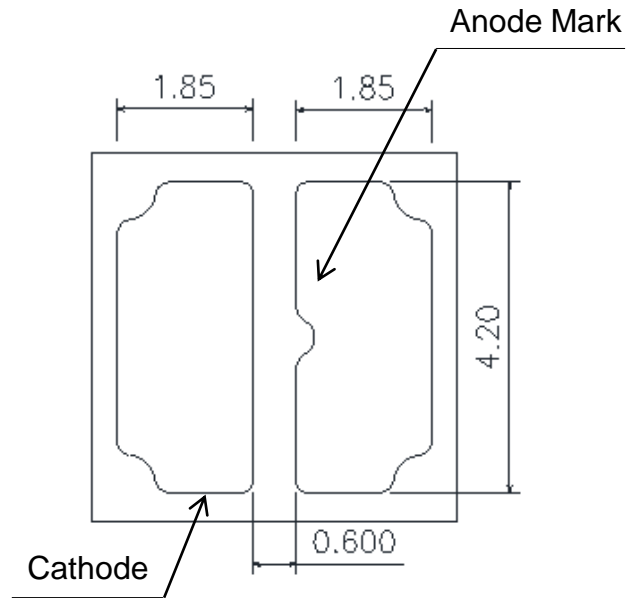

< Side view >



Circuit Array

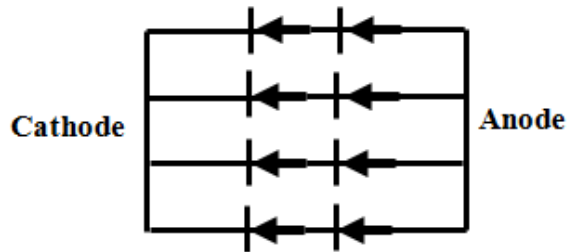

Notes :

- (1) All dimensions are in millimeters.
- (2) Scale : none
- (3) Undefined tolerance is $\pm 0.2\text{mm}$

Recommended Solder Pad

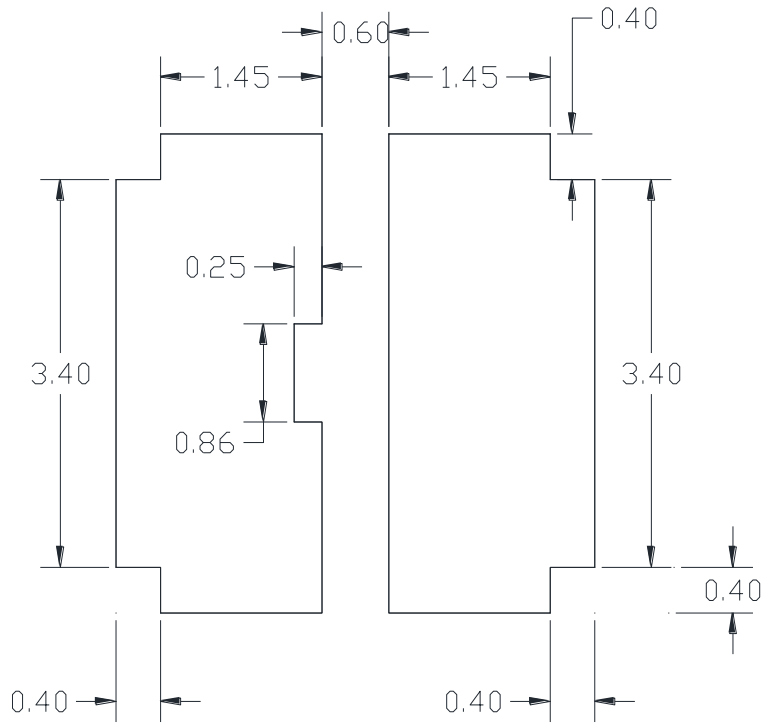

- (1) All dimensions are in millimeters.
- (2) Scale : none
- (3) Undefined tolerance is $\pm 0.2\text{mm}$
- (4) This drawing without tolerances are for reference only.

Reliability Test Item & Condition

Test Item	Test conditions	Time/cycle	Q'ty
High Temperature Operating Life	Ta = 85°C	1000	20
Low Temperature Operating Life	T _{amb} -40 °C. or -20 °C with On/Off (5min/5min)	1000	20
Temperature Shock	Ta = -40 °C ↔ 120 °C, Dwell time : 30 min (on PCB)	1000	40
High Temperature High Humidity	Ta=85°C, RH=85%	1000	10
H2S corrosion	40°C / 80%, H2S 15ppm	504	10
ESD	HBM, 2KV, 1.5kΩ, 100pF, Alternately positive or negative	-	20

Reflow Soldering Characteristics

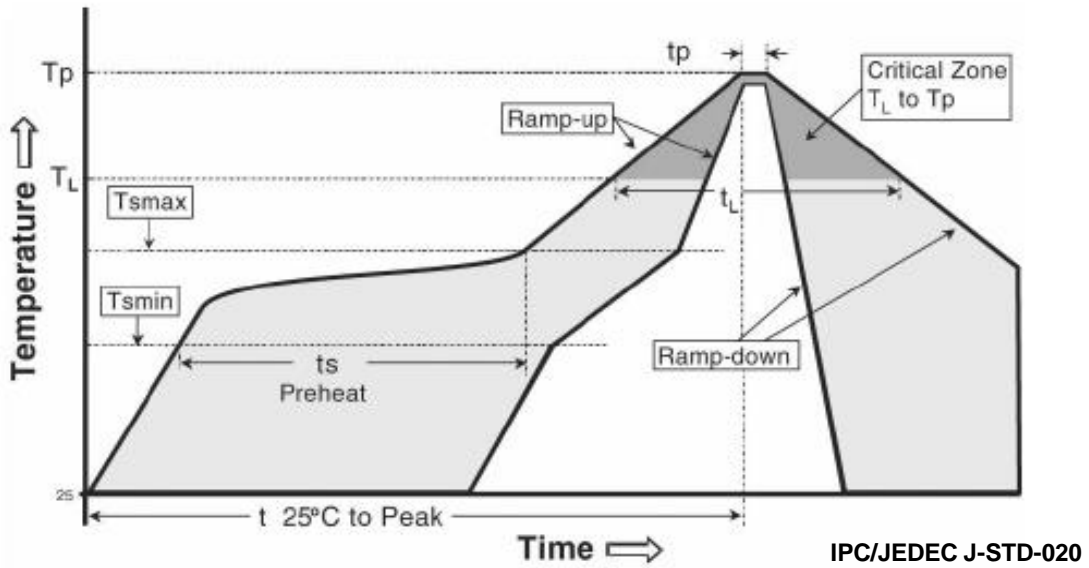

Profile Feature	Sn-Pb Eutectic Assembly	Pb-Free Assembly
Average ramp-up rate (T _{smax} to T _p)	3° C/second max.	3° C/second max.
Preheat - Temperature Min (T _{smin}) - Temperature Max (T _{smax}) - Time (T _{smin} to T _{smax}) (t _s)	100 °C 150 °C 60-120 seconds	150 °C 200 °C 60-180 seconds
Time maintained above: - Temperature (T _L) - Time (t _L)	183 °C 60-150 seconds	217 °C 60-150 seconds
Peak Temperature (T _p)	215°C	260°C
Time within 5°C of actual Peak Temperature (t _p) ²	10-30 seconds	20-40 seconds
Ramp-down Rate	6 °C/second max.	6 °C/second max.
Time 25°C to Peak Temperature	6 minutes max.	8 minutes max.

Caution

- (1) Reflow soldering is recommended not to be done more than two times. In the case of more than 24 hours passed soldering after first, LEDs will be damaged.
- (2) Repairs should not be done after the LEDs have been soldered. When repair is unavoidable, suitable tools must be used.
- (3) Die slug is to be soldered.
- (4) When soldering, do not put stress on the LEDs during heating.
- (5) After soldering, do not warp the circuit board.

Emitter Tape & Reel Packaging

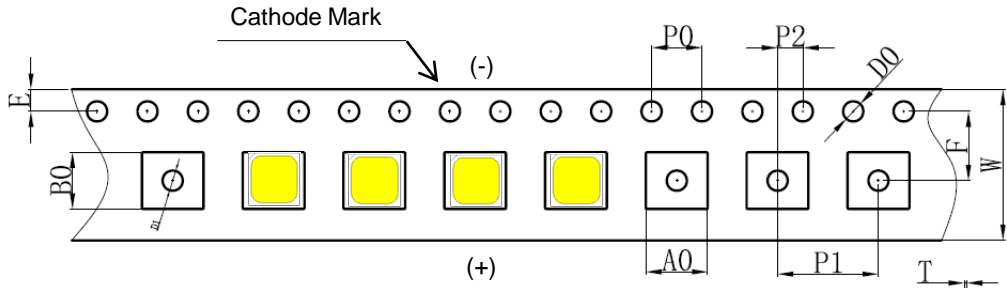

Symbol	W	T	K0	A0	B0	E
Dimension (mm)	12.00	0.20	0.95	5.35	5.40	1.75
Symbol	F	D0	D1	P0	P1	P2
Dimension (mm)	5.50	1.60	1.60	4.00	8.00	2.00

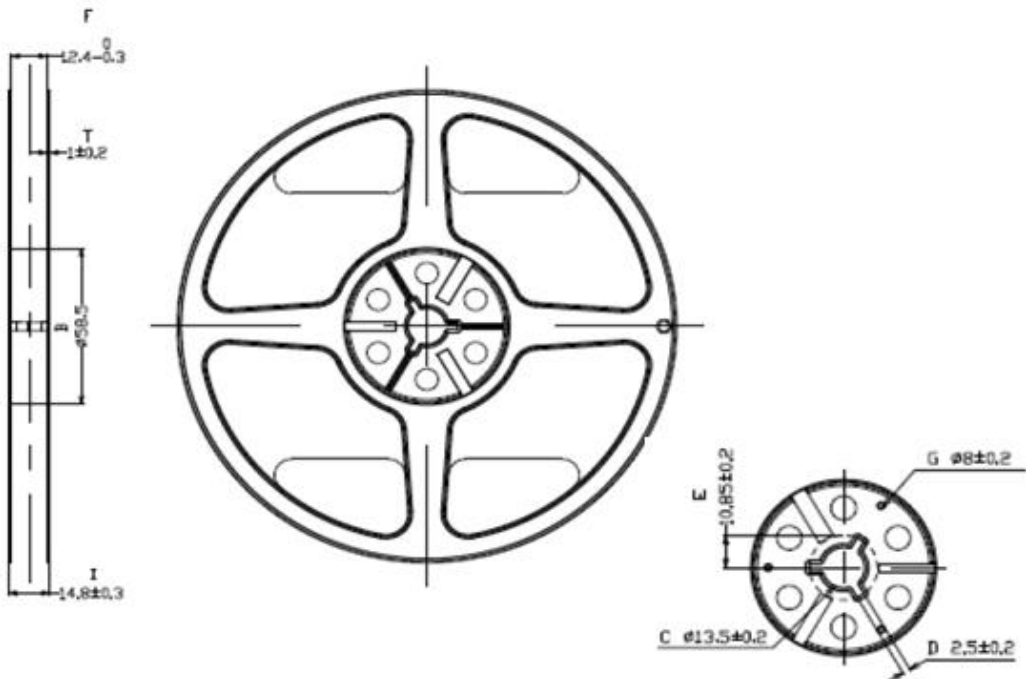
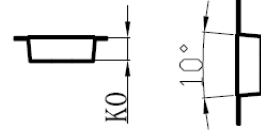

Notes :

- (1) Quantity : 7 inch reel type (2,000 pcs / Reel \pm 1pcs)
- (2) Cumulative Tolerance : Cumulative Tolerance/10 pitches to be \pm 0.2mm
- (3) Adhesion Strength of Cover Tape : Adhesion strength to be 0.1-0.7N when the cover tape is turned off from the carrier tape at the angle of 10° to the carrier tape
- (4) Package : P/N, Manufacturing data Code No. and quantity to be indicated on a damp proof Package.

Emitter Tape & Reel Packaging

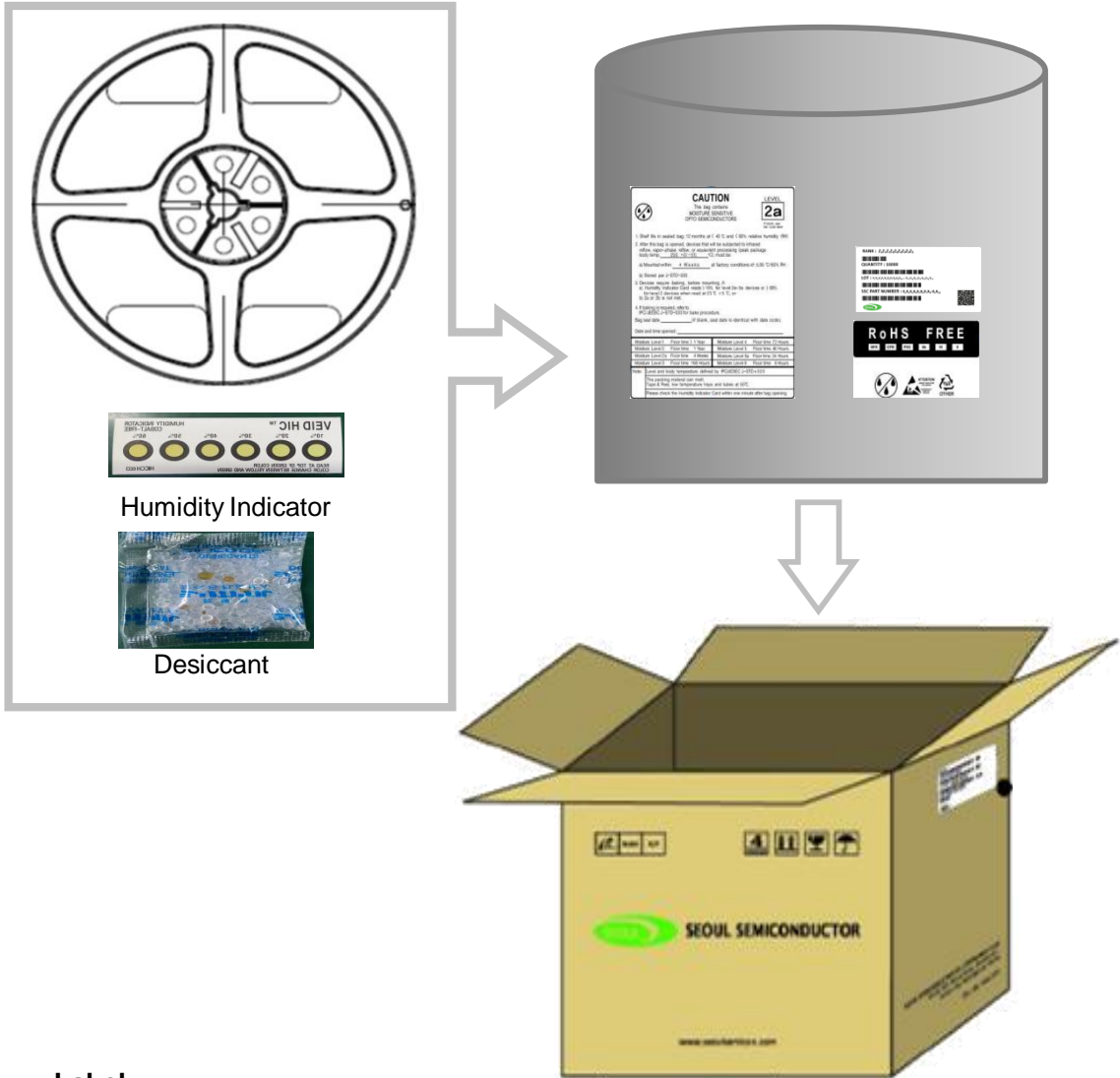

Label

RANK : Z₁Z₁Z₁Z₂Z₂Z₂Z₃Z₃

QUANTITY : 2000

LOT : Y₁Y₂Y₃Y₄Y₅Y₆Y₇Y₈Y₉Y₁₀ - Y₁₁Y₁₂Y₁₃Y₁₄Y₁₅Y₁₆Y₁₇

SSC PART NUMBER : X₁X₂X₃X₄X₅X₆X₇X₈-X₉X₁₀

Notes :

- (1) Rank : Flux: Z₁Z₁Z₁, CIE: Z₂Z₂Z₂, VF: Z₃Z₃Z₃
- (2) Quantity : Max 2,000pcs/Reel
- (3) Lot no.: Y₁Y₂Y₃Y₄Y₅Y₆Y₇Y₈Y₉Y₁₀ – SSC code -Z₁Z₁Z₁Z₂Z₂Z₂Z₃Z₃Z₃
- (4) SSC part Number : X₁X₂X₃X₄X₅X₆X₇X₈-X₉X₁₀

Handling of Silicone Resin for LEDs

(1) During processing, mechanical stress on the surface should be minimized as much as possible. Sharp objects of all types should not be used to pierce the sealing compound.



(2) In general, LEDs should only be handled from the side. By the way, this also applies to LEDs without a silicone sealant, since the surface can also become scratched.

(3) When populating boards in SMT production, there are basically no restrictions regarding the form of the pick and place nozzle, except that mechanical pressure on the surface of the resin must be prevented. This is assured by choosing a pick and place nozzle which is larger than the LED's reflector area.

(4) Silicone differs from materials conventionally used for the manufacturing of LEDs. These conditions must be considered during the handling of such devices. Compared to standard encapsulants, silicone is generally softer, and the surface is more likely to attract dust.

As mentioned previously, the increased sensitivity to dust requires special care during processing. In cases where a minimal level of dirt and dust particles cannot be guaranteed, a suitable cleaning solution must be applied to the surface after the soldering of components.

(5) SSC suggests using isopropyl alcohol for cleaning. In case other solvents are used, it must be assured that these solvents do not dissolve the package or resin.

Ultrasonic cleaning is not recommended. Ultrasonic cleaning may cause damage to the LED.

(6) Please do not mold this product into another resin (epoxy, urethane, etc) and do not handle this product with acid or sulfur material in sealed space.

Precaution for Use

(1) Storage

To avoid the moisture penetration, we recommend store in a dry box with a desiccant.

The maximum storage temperature range is 40°C and a maximum humidity of RH90%.

(2) Use Precaution after Opening the Packaging

Use SMT techniques properly when the LED is to be soldered dipped as separation of the lens may affect the light output efficiency.

Pay attention to the following:

a. Recommend conditions after opening the package

- Sealing

- Temperature : 30°C Humidity : less than RH60%

b. If the package has been opened more than 4 week(MSL_2a) or the color of the desiccant changes, components should be dried for 10-24hr at 65±5°C

(3) Do not apply mechanical force or excess vibration during the cooling process to normal temperature after soldering.

(4) Do not rapidly cool device after soldering.

(5) Components should not be mounted on warped (non coplanar) portion of PCB.

(6) Radioactive exposure is not considered for the products listed here in.

(7) Gallium arsenide is used in some of the products listed in this publication.

These products are dangerous if they are burned or shredded in the process of disposal.

It is also dangerous to drink the liquid or inhale the gas generated by such products when chemically disposed of.

(8) This device should not be used in any type of fluid such as water, oil, organic solvent and etc.

When washing is required, IPA (Isopropyl Alcohol) should be used.

(9) When the LEDs are in operation the maximum current should be decided after measuring the package temperature.

(10) Don't recommend to use it for cold storage lighting.

Precaution for Use

- (11) The appearance and specifications of the product may be modified for improvement without notice.
- (12) Long time exposure of sunlight or occasional UV exposure will cause lens discoloration.
- (13) VOCs (Volatile organic compounds) emitted from materials used in the construction of fixtures can penetrate silicone encapsulants of LEDs and discolor when exposed to heat and photonic energy. The result can be a significant loss of light output from the fixture. Knowledge of the properties of the materials selected to be used in the construction of fixtures can help prevent these issues.
- (14) Attaching LEDs, do not use adhesives that outgas organic vapor.
- (15) The driving circuit must be designed to allow forward voltage only when it is ON or OFF.
If the reverse voltage is applied to LED, migration can be generated resulting in LED damage.

- (16) Similar to most Solid state devices;
LEDs are sensitive to Electro-Static Discharge (ESD) and Electrical Over Stress (EOS).
Below is a list of suggestions that Seoul Semiconductor purposes to minimize these effects.

(17) Voltage Variation Mixing

If Module circuit series and parallel many PKG, voltage variation problem coming out seriously. To avoid this issue we recommend mixing Vf bin at the SMD Module Program level. Even though using Single bin only.

For example, when configuring a module with two reels (reel1 and Reel2), SMT should be as follows Good below.

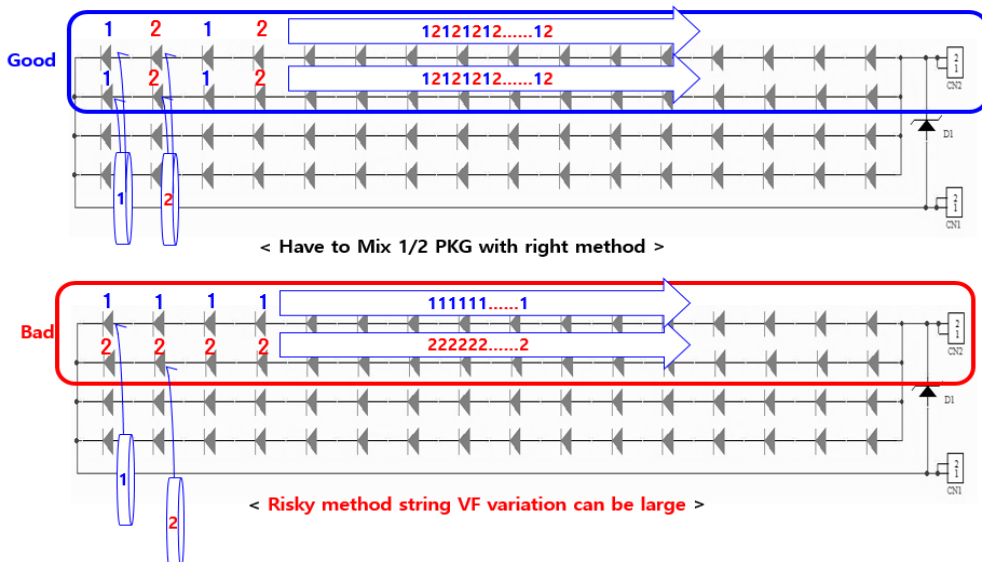

Precaution for Use

a. ESD (Electro Static Discharge)

Electrostatic discharge (ESD) is defined as the release of static electricity when two objects come into contact. While most ESD events are considered harmless, it can be an expensive problem in many industrial environments during production and storage. The damage from ESD to LEDs may cause the product to demonstrate unusual characteristics such as:

- Increase in reverse leakage current lowered turn-on voltage
- Abnormal emissions from the LED at low current

The following recommendations are suggested to help minimize the potential for an ESD event.

One or more recommended work area suggestions:

- Ionizing fan setup
- ESD table/shelf mat made of conductive materials
- ESD safe storage containers

One or more personnel suggestion options:

- Antistatic wrist-strap
- Antistatic material shoes
- Antistatic clothes

Environmental controls:

- Humidity control (ESD gets worse in a dry environment)

b. EOS (Electrical Over Stress)

Electrical Over-Stress (EOS) is defined as damage that may occur when an electronic device is subjected to a current or voltage that is beyond the maximum specification limits of the device.

The effects from an EOS event can be noticed through product performance like:

- Changes to the performance of the LED package
(If the damage is around the bond pad area and since the package is completely encapsulated the package may turn on but flicker show severe performance degradation.)
- Changes to the light output of the luminaire from component failure
- Components on the board not operating at determined drive power

Failure of performance from entire fixture due to changes in circuit voltage and current across total circuit causing trickle down failures. It is impossible to predict the failure mode of every LED exposed to electrical overstress as the failure modes have been investigated to vary, but there are some common signs that will indicate an EOS event has occurred:

- Damaged may be noticed to the bond wires (appearing similar to a blown fuse)
- Damage to the bond pads located on the emission surface of the LED package
(shadowing can be noticed around the bond pads while viewing through a microscope)
- Anomalies noticed in the encapsulation and phosphor around the bond wires.
- This damage usually appears due to the thermal stress produced during the EOS event.

c. To help minimize the damage from an EOS event Seoul Semiconductor recommends utilizing:

- A surge protection circuit
- An appropriately rated over voltage protection device
- A current limiting device

Company Information

Published by

Seoul Semiconductor © 2013 All Rights Reserved.

Company Information

Seoul Semiconductor (www.SeoulSemicon.com) manufactures and packages a wide selection of light emitting diodes (LEDs) for the automotive, general illumination/lighting, Home appliance, signage and back lighting markets. The company is the world's fifth largest LED supplier, holding more than 10,000 patents globally, while offering a wide range of LED technology and production capacity in areas such as "nPola", "Acrich", the world's first commercially produced AC LED, and "Acrich MJT - Multi-Junction Technology" a proprietary family of high-voltage LEDs.

The company's broad product portfolio includes a wide array of package and device choices such as Acrich and Acirch2, high-brightness LEDs, mid-power LEDs, side-view LEDs, and through-hole type LEDs as well as custom modules, displays, and sensors.

Legal Disclaimer

Information in this document is provided in connection with Seoul Semiconductor products. With respect to any examples or hints given herein, any typical values stated herein and/or any information regarding the application of the device, Seoul Semiconductor hereby disclaims any and all warranties and liabilities of any kind, including without limitation, warranties of non-infringement of intellectual property rights of any third party. The appearance and specifications of the product can be changed to improve the quality and/or performance without notice.