

DC Module

SMJD-4253182B-XXN1



Product Brief

Description

- Multiple CCT is optional
- Modular design concept, easily expand to multitude application
- Poke-in connector in built

Features and Benefits

- High Efficacy
- Long Life Time
- Simple BOM
- Lead Free Product
- RoHS Compliant

Key Applications

- Linear lighting
- Decorative lighting
- Troffer

Product Code Information

Table 1. Order Code

CCT	CRI	Lens type	Order Code
3000	80	-	SMJD-4253182B-XXN100J45G038All
3500	80	-	SMJD-4253182B-XXN100J45F038All
4000	80	-	SMJD-4253182B-XXN100J70E038All
5000	80	-	SMJD-4253182B-XXN100J70C038All

Notes:

(1) Order code include 18D(Part Name) + 2D(lens Type) + 10D(Characteristics)

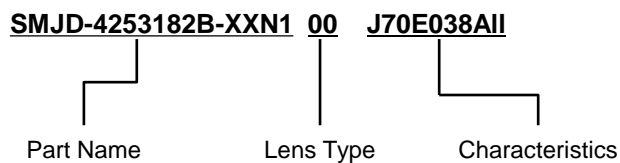

Table of Contents

Index	
• Product Brief	
• Table of Contents	
• Performance Characteristics	
• Absolute Maximum Ratings	
• Relative Spectral Distribution	
• Color Bin Structure	
• Mechanical Dimensions	
• Product Nomenclature	
• Marking Information	
• Label Information	
• Packing Introduction	
• Precaution for Use	
• Storage before use	
• Guidelines for properly working with module	
• Company Information	
• Revision History	

Performance Characteristics

Parameter	Symbol	Value			Unit	Mark
		Min.	Typ.	Max.		
Luminous Flux	Φ_V [2]	9020	9700	-	lm	C,E rank
		8790	9450	-		F,G rank
Luminous Efficiency	LPW	180			Lm/W	C,E rank
		175				F,G rank
Correlated Color Temperature [3]	CCT	2900	3000	3200	K	G rank
		3200	3500	3700		F rank
		3700	4000	4200		E rank
		4700	5000	5300		C rank
CRI	Ra	80	-	-	-	
Color Consistency		-	-	3	SDCM	
Input Voltage	V_{in}	40	41.5	43	Vdc	
Forward Current	I_F	1300			mA	
Power Consumption	P	52	54	55.9	W	
Viewing Angle	$2\Theta_{1/2}$	120			deg.	

Notes :

- (1) The above data were tested at $T_c=25^\circ\text{C}$.
- (2) Φ_V is the total luminous flux output measured with an integrated sphere, the tolerance is 7% .
- (3) Correlated Color Temperature is derived from the CIE 1931 Chromaticity diagram.
- (4) To use the module properly, recommend to drive the module by a Constant Current Source (CCS). But the Maximum output voltage of the CCS should be limited by referring this datasheet.

Absolute Maximum Ratings

Table 3. Absolute Maximum Ratings, $T_c = 25^\circ\text{C}$ ⁽¹⁾

Parameter	Symbol	Unit	Value	Remark
Power Consumption	P	W	79	$P_{Typ.} = 54\text{W}$
Forward Voltage	V_F	Vdc	43.5	
Driving Current ⁽²⁾	I_F	A	1.82	$I_{F_Typ.} = 1.3\text{A}$
Operating Temperature ⁽³⁾	T_c	$^\circ\text{C}$	- 40 ~ 85	Reference point
Storage Temperature	T_{stg}	$^\circ\text{C}$	- 40 ~ 100	With no power
ESD Sensitivity	-	KV	± 8	IEC Air
			± 4	HBM

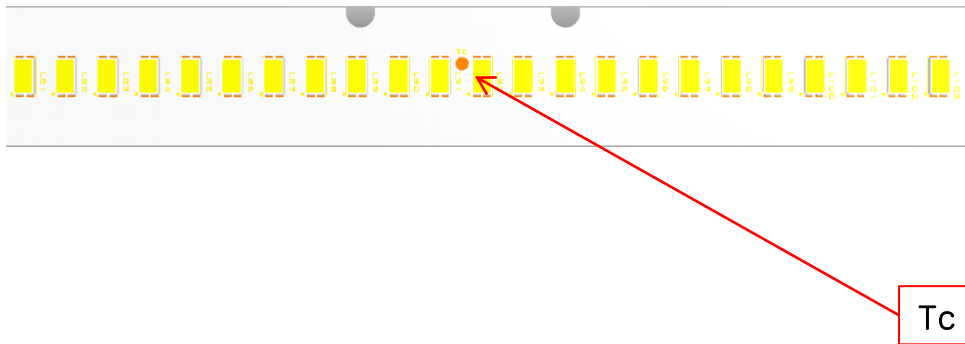
ILLUSTRATION 1: How to predict components temperature ⁽⁴⁾

Notes :

- (1) All guarantee are based on the Absolute Maximum Ratings listed.
- (2) Please use a Constant Current Source (CCS) to drive the module, the typical V_F of module is around 41.5VDC and V_{F_MAX} is around 43VDC, respectively.
- (3) Operating temperature was tested at the assigned T_c point on the PCB.
- (4) To ensure the module works properly, DO NOT let the T_c upper than 85 $^\circ\text{C}$;

Relative Spectral Distribution

Fig 1. Relative Spectral Distribution vs. Wavelength Characteristic

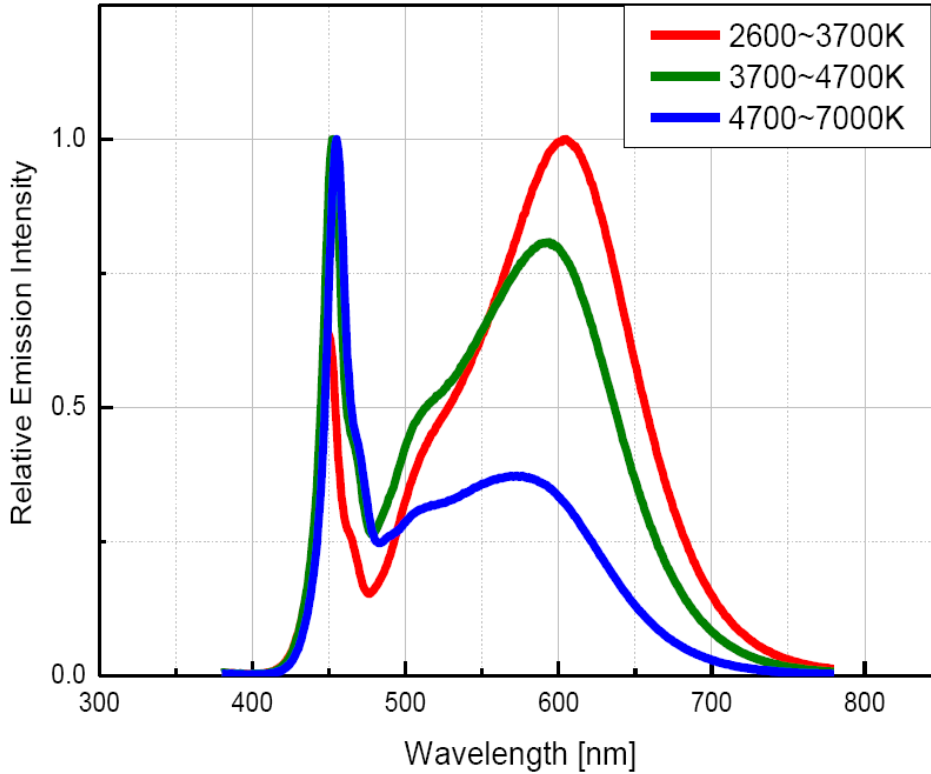
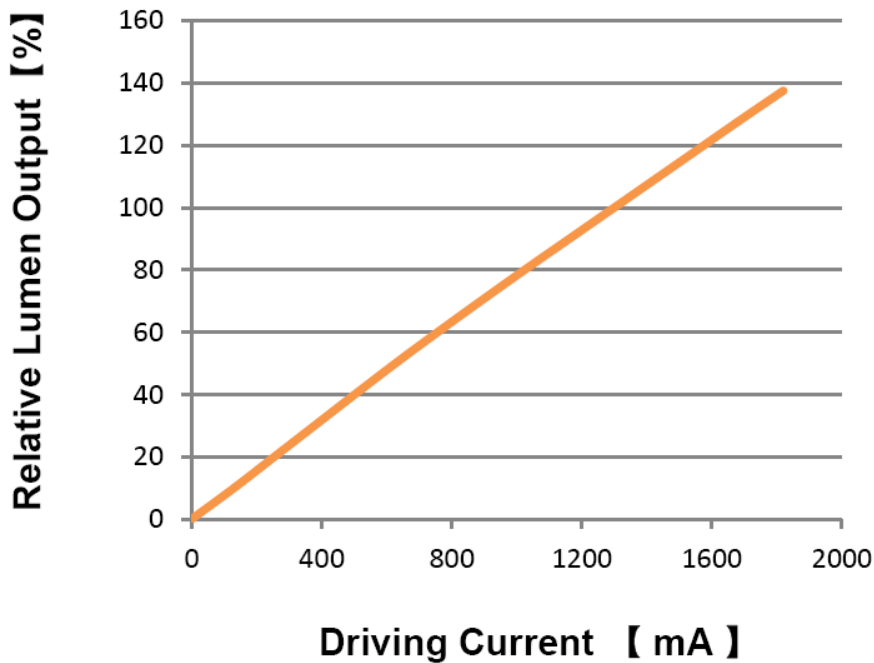
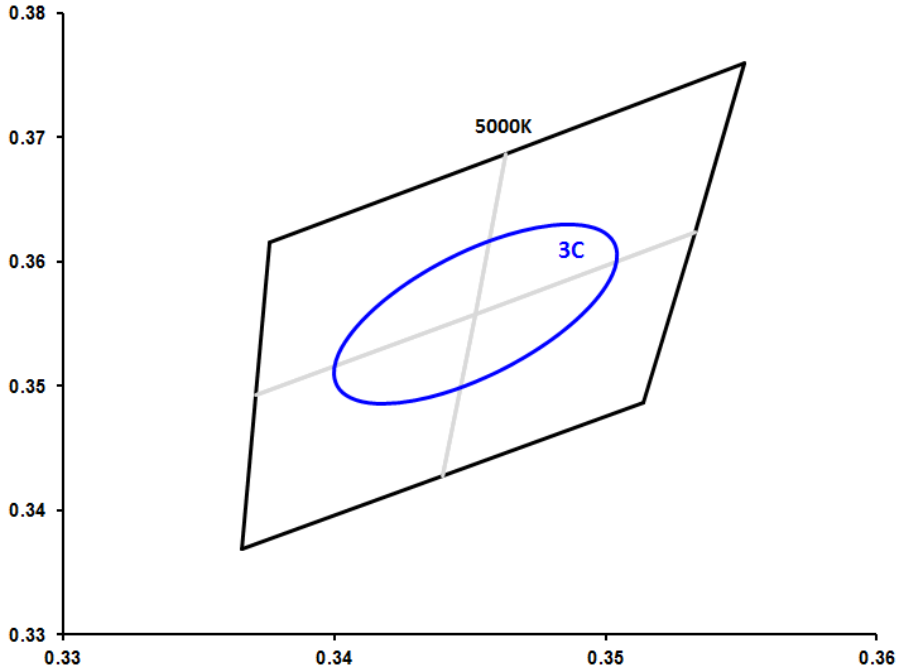

Fig 2. Forward Current vs. Relative Luminous Flux, $T_c=25^\circ\text{C}$



Color Bin Structure

Fig 3. CIE Chromaticity Diagram

5000K 3Step

3C							
CIE X	CIE Y	CIE X	CIE Y	CIE X	CIE Y	CIE X	CIE Y
0.3491	0.3558	0.3452	0.3612	0.3413	0.3558	0.3452	0.3504
0.3493	0.3561	0.3449	0.3609	0.3411	0.3555	0.3455	0.3507
0.3494	0.3563	0.3446	0.3607	0.3410	0.3553	0.3458	0.3509
0.3495	0.3566	0.3443	0.3604	0.3409	0.3550	0.3461	0.3512
0.3496	0.3569	0.3441	0.3601	0.3408	0.3547	0.3463	0.3515
0.3498	0.3573	0.3439	0.3599	0.3406	0.3543	0.3465	0.3517
0.3499	0.3577	0.3437	0.3596	0.3405	0.3539	0.3467	0.3520
0.3500	0.3581	0.3435	0.3594	0.3404	0.3535	0.3469	0.3522
0.3501	0.3585	0.3433	0.3592	0.3403	0.3531	0.3471	0.3524
0.3503	0.3590	0.3432	0.3590	0.3401	0.3526	0.3472	0.3526
0.3503	0.3595	0.3430	0.3588	0.3401	0.3521	0.3474	0.3528
0.3504	0.3601	0.3429	0.3586	0.3400	0.3515	0.3475	0.3530
0.3504	0.3607	0.3428	0.3584	0.3400	0.3509	0.3476	0.3532
0.3504	0.3613	0.3426	0.3582	0.3400	0.3503	0.3478	0.3534
0.3502	0.3619	0.3425	0.3580	0.3402	0.3497	0.3479	0.3536
0.3500	0.3623	0.3424	0.3578	0.3404	0.3493	0.3480	0.3538
0.3496	0.3627	0.3423	0.3577	0.3408	0.3489	0.3481	0.3539
0.3491	0.3629	0.3422	0.3575	0.3413	0.3487	0.3482	0.3541
0.3486	0.3630	0.3420	0.3573	0.3418	0.3486	0.3484	0.3543
0.3480	0.3629	0.3419	0.3571	0.3424	0.3487	0.3485	0.3545
0.3475	0.3628	0.3418	0.3569	0.3429	0.3488	0.3486	0.3547
0.3469	0.3625	0.3417	0.3567	0.3435	0.3491	0.3487	0.3549
0.3464	0.3622	0.3416	0.3565	0.3440	0.3494	0.3488	0.3551
0.3460	0.3619	0.3415	0.3563	0.3444	0.3497	0.3489	0.3553
0.3456	0.3616	0.3414	0.3560	0.3448	0.3500	0.3490	0.3556

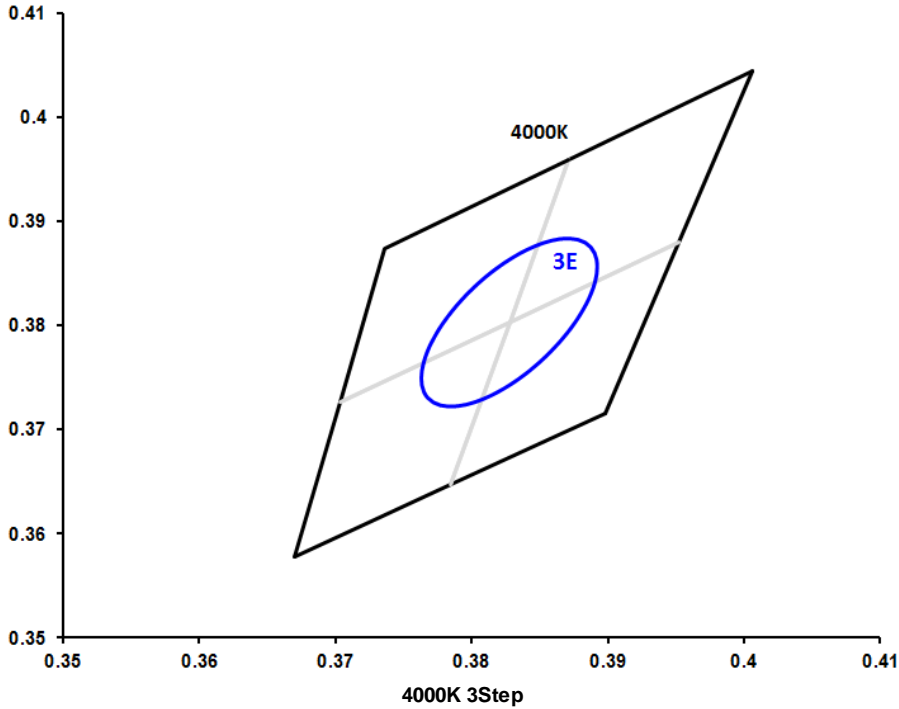
Color Bin Structure

Fig 4. CIE Chromaticity Diagram

4000K 3Step							
3E							
CIE X	CIE Y	CIE X	CIE Y	CIE X	CIE Y	CIE X	CIE Y
0.3876	0.3803	0.3827	0.3863	0.3779	0.3803	0.3827	0.3743
0.3877	0.3806	0.3824	0.3860	0.3778	0.3800	0.3831	0.3746
0.3879	0.3810	0.3821	0.3857	0.3776	0.3796	0.3834	0.3749
0.3881	0.3813	0.3818	0.3854	0.3774	0.3793	0.3837	0.3752
0.3883	0.3817	0.3815	0.3852	0.3772	0.3789	0.3840	0.3754
0.3884	0.3821	0.3812	0.3849	0.3771	0.3785	0.3843	0.3757
0.3886	0.3826	0.3810	0.3847	0.3769	0.3780	0.3845	0.3759
0.3888	0.3831	0.3808	0.3844	0.3767	0.3775	0.3847	0.3762
0.3889	0.3837	0.3806	0.3842	0.3766	0.3769	0.3849	0.3764
0.3891	0.3843	0.3804	0.3840	0.3764	0.3763	0.3851	0.3766
0.3892	0.3850	0.3802	0.3838	0.3763	0.3756	0.3853	0.3768
0.3892	0.3856	0.3801	0.3836	0.3763	0.3750	0.3854	0.3770
0.3892	0.3863	0.3799	0.3833	0.3763	0.3743	0.3856	0.3773
0.3890	0.3870	0.3797	0.3831	0.3765	0.3736	0.3858	0.3775
0.3887	0.3875	0.3796	0.3829	0.3768	0.3731	0.3859	0.3777
0.3883	0.3880	0.3794	0.3827	0.3772	0.3726	0.3861	0.3779
0.3878	0.3883	0.3793	0.3825	0.3777	0.3723	0.3862	0.3781
0.3872	0.3884	0.3791	0.3823	0.3783	0.3722	0.3864	0.3783
0.3865	0.3883	0.3790	0.3821	0.3790	0.3723	0.3865	0.3785
0.3859	0.3882	0.3788	0.3818	0.3796	0.3724	0.3867	0.3788
0.3852	0.3879	0.3787	0.3816	0.3803	0.3727	0.3868	0.3790
0.3846	0.3876	0.3785	0.3814	0.3809	0.3730	0.3870	0.3792
0.3841	0.3873	0.3784	0.3811	0.3814	0.3733	0.3871	0.3795
0.3836	0.3870	0.3782	0.3809	0.3819	0.3736	0.3873	0.3797
0.3831	0.3867	0.3781	0.3806	0.3824	0.3739	0.3874	0.3800

Color Bin Structure

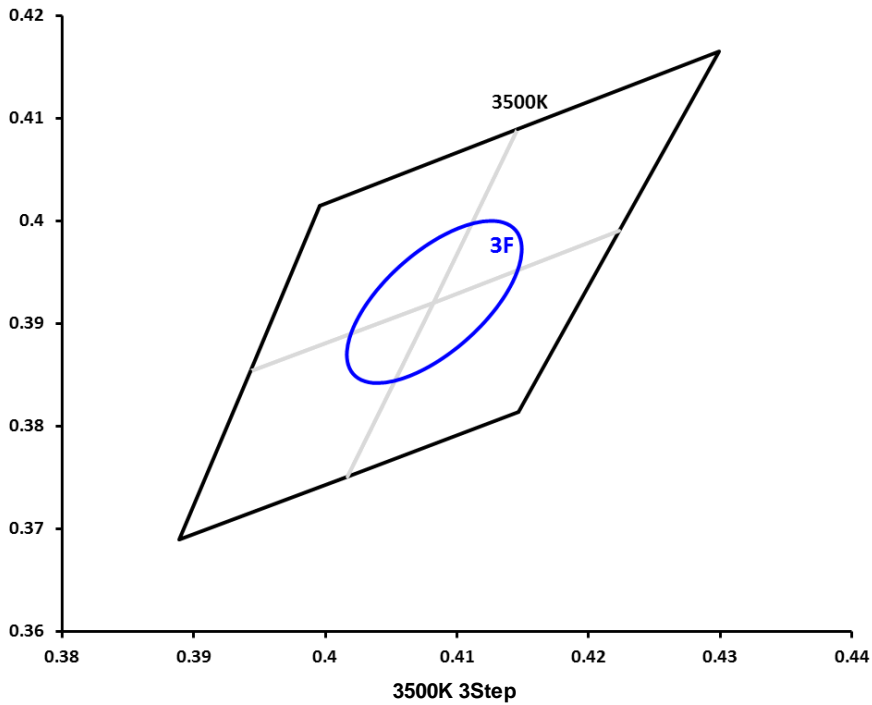
Fig 5. CIE Chromaticity Diagram

3500K 3Step							
3F							
CIE X	CIE Y	CIE X	CIE Y	CIE X	CIE Y	CIE X	CIE Y
0.4133	0.3921	0.4083	0.3981	0.4032	0.3921	0.4083	0.3861
0.4135	0.3924	0.4079	0.3978	0.4031	0.3918	0.4086	0.3864
0.4137	0.3928	0.4076	0.3975	0.4029	0.3914	0.4090	0.3867
0.4139	0.3932	0.4073	0.3973	0.4027	0.3910	0.4093	0.3869
0.4140	0.3936	0.4070	0.3970	0.4025	0.3906	0.4095	0.3872
0.4142	0.3940	0.4068	0.3968	0.4023	0.3902	0.4098	0.3874
0.4144	0.3945	0.4065	0.3965	0.4022	0.3897	0.4100	0.3877
0.4146	0.3951	0.4063	0.3963	0.4020	0.3891	0.4103	0.3879
0.4147	0.3956	0.4061	0.3961	0.4018	0.3886	0.4105	0.3881
0.4148	0.3963	0.4059	0.3959	0.4017	0.3879	0.4107	0.3883
0.4149	0.3969	0.4057	0.3956	0.4016	0.3873	0.4108	0.3886
0.4149	0.3976	0.4055	0.3954	0.4016	0.3866	0.4110	0.3888
0.4148	0.3982	0.4053	0.3952	0.4017	0.3860	0.4112	0.3890
0.4146	0.3988	0.4052	0.3950	0.4020	0.3854	0.4114	0.3892
0.4143	0.3993	0.4050	0.3948	0.4023	0.3849	0.4115	0.3894
0.4138	0.3997	0.4049	0.3946	0.4027	0.3845	0.4117	0.3896
0.4132	0.3999	0.4047	0.3944	0.4033	0.3843	0.4119	0.3898
0.4126	0.4000	0.4045	0.3942	0.4039	0.3842	0.4120	0.3900
0.4120	0.3999	0.4044	0.3939	0.4046	0.3843	0.4122	0.3903
0.4113	0.3998	0.4042	0.3937	0.4052	0.3844	0.4123	0.3905
0.4107	0.3996	0.4041	0.3935	0.4059	0.3846	0.4125	0.3907
0.4101	0.3993	0.4039	0.3932	0.4064	0.3849	0.4127	0.3910
0.4096	0.3990	0.4037	0.3930	0.4070	0.3852	0.4128	0.3912
0.4091	0.3987	0.4036	0.3927	0.4074	0.3855	0.4130	0.3915
0.4087	0.3984	0.4034	0.3924	0.4079	0.3858	0.4131	0.3918

Color Bin Structure

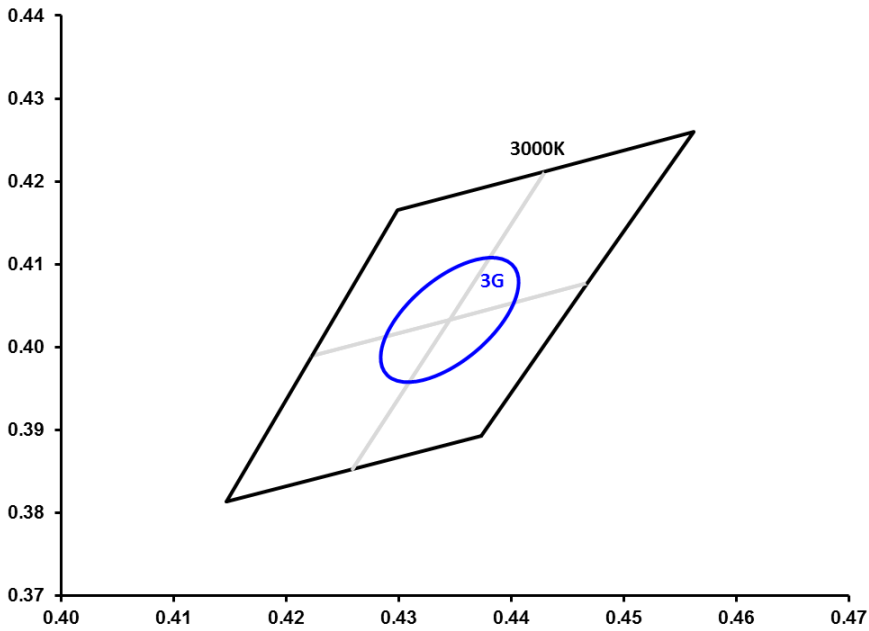
Fig 6. CIE Chromaticity Diagram

3000K 3Step

3G							
CIE X	CIE Y	CIE X	CIE Y	CIE X	CIE Y	CIE X	CIE Y
0.4394	0.4033	0.4345	0.4093	0.4297	0.4033	0.4345	0.3973
0.4395	0.4036	0.4342	0.4090	0.4295	0.4030	0.4349	0.3976
0.4397	0.4040	0.4338	0.4087	0.4294	0.4026	0.4352	0.3979
0.4398	0.4043	0.4335	0.4085	0.4292	0.4023	0.4355	0.3981
0.4400	0.4047	0.4333	0.4082	0.4290	0.4019	0.4358	0.3984
0.4402	0.4051	0.4330	0.4080	0.4289	0.4015	0.4360	0.3986
0.4403	0.4056	0.4328	0.4077	0.4288	0.4010	0.4363	0.3989
0.4404	0.4061	0.4326	0.4075	0.4286	0.4005	0.4365	0.3991
0.4405	0.4066	0.4323	0.4073	0.4285	0.4000	0.4367	0.3993
0.4406	0.4072	0.4322	0.4070	0.4284	0.3994	0.4369	0.3996
0.4407	0.4078	0.4320	0.4068	0.4284	0.3988	0.4371	0.3998
0.4406	0.4084	0.4318	0.4066	0.4284	0.3982	0.4373	0.4000
0.4405	0.4089	0.4316	0.4064	0.4285	0.3977	0.4374	0.4002
0.4403	0.4095	0.4315	0.4062	0.4287	0.3971	0.4376	0.4004
0.4401	0.4100	0.4313	0.4060	0.4290	0.3966	0.4378	0.4006
0.4397	0.4104	0.4311	0.4058	0.4294	0.3962	0.4379	0.4008
0.4392	0.4106	0.4310	0.4055	0.4299	0.3960	0.4381	0.4011
0.4386	0.4108	0.4308	0.4053	0.4304	0.3958	0.4382	0.4013
0.4381	0.4108	0.4307	0.4051	0.4310	0.3958	0.4384	0.4015
0.4375	0.4107	0.4305	0.4049	0.4316	0.3959	0.4385	0.4017
0.4369	0.4106	0.4304	0.4046	0.4322	0.3960	0.4386	0.4020
0.4363	0.4103	0.4303	0.4044	0.4327	0.3963	0.4388	0.4022
0.4358	0.4101	0.4301	0.4041	0.4332	0.3965	0.4389	0.4025
0.4353	0.4098	0.4300	0.4039	0.4337	0.3968	0.4391	0.4027
0.4349	0.4095	0.4298	0.4036	0.4341	0.3971	0.4392	0.4030

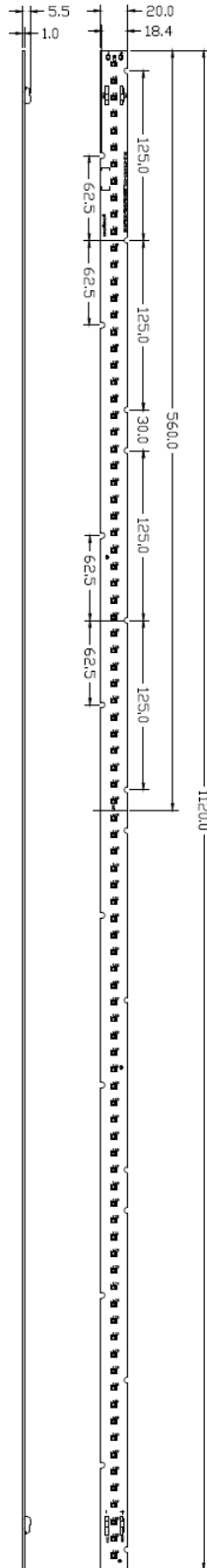
Mechanical Dimensions



Notes :

1. All dimensions are in millimeters.
2. Scale : none

Product Nomenclature

Product Name Rule:

S M J D - 42 53 182 B - XX N 1
 ① ② ③ ④ ⑤ ⑥ ⑦ ⑧

①: SMJD – Seoul Outdoor Module
 ② ~ ⑧: Refer to below table

Voltage				Power				LED Qty.						LED Type		Customer (Free)		Dimming		Etc. (Free)			
②				③				④						⑤		⑥		⑦		⑧			
4	2	5	3	1	8	2	B	XX		N		1											
0	0	0	0	0	0	0	0	0	0	0	0	0	0	0	0	B	5630D	XX	Reference	N	Normal	1	Version
1	10V	1	1V	1	10W	1	1W	1	100EA	1	10EA	1	1EA					D	Dimming				
2	20V	2	2V	2	20W	2	2W	2	200EA	2	20EA	2	2EA					E	Etc.				
3	30V	3	3V	3	30W	3	3W	3	300EA	3	30EA	3	3EA										
...										
9	90V	9	9V	9	90W	9	9W	9	900EA	9	90EA	9	9EA										
A	100V			A	100W			A	1000EA														
B	110V			B	110W																		
...																		
Z	350V			Z	350W																		

Comments Rule:

(00 WN 80)
A B C

Lens Type		CCT		CRI	
A		B		C	
00		WN		80	
00	No lens	W0	6500K	80	CRI80
			5700K	90	CRI90
			5000K		
		WN	4500K		
			4000K		
		WW	3500K		
			3000K		
			2700K		

Product Nomenclature

Characteristics Rule:

00 J70 E03 8 All
A **B** **C** **D** **E**

Lens type		Flux bin		CCT bin		CRI bin		VF bin	
A		B		C		D		E	
00		J70		E03		8		ALL	
00	No lens	J70	9700 lm	C03	5000K 3-step	8	CR180	ALL	DC 40~43V
		J45	9450lm	E03	4000K 3-step	9	CR190		
				F03	3500K 3-step				
				G03	3000K 3-step				

Marking Information

Fig 7. Marking Point

Marking point

QR Code Information

YYMMDD

J70E03

8ALL

100001

①

②

③

④

QR Code Information								
Items	Factory	SAP Code	SMT Date	MP Information	Line No.	Lot No.	Product	Note
Digits	1 Digits	7 Digits	6 Digits	10 Digits	1 Digit	1 Digit	5 Digits	In Total 31 Digits
Information	*	*****	YYMMD D	J70E03 8ALL	1~9, A~Z	1~9, A~Z	00001	

Notes:















- 1 QR coded information shall include the fields described in the table above.
- 2 Minimum size of QR code shall be 4.5 mm x 4.5 mm and a minimum QR code grade of 'C'.
*A' grading is preferred.
- 3 If the component is small to have a full label, it is acceptable to have only the QR code in minimum size of 6 mm by 6 mm printed on a label.
- 4 QR Code Example: X XXXXXXXX 180827 J70E038ALL 1 1 00001

Plain Code Information

No.	Item	Information	Digits	Remark
①	Date	YYMMDD	6Digit	SMT date
②	Flux ⁽¹⁾	J70	3Digit	J70=9700Im
	CCT	X03 3- step	3Digit	X=C,E,F,G
③	CRI	8	1Dight	CRI=80
	V _F	ALL	3Digit	Y1 or Y2
④	Lot No.	1	1 Digit	0~9,A~Z
	Sequence No.	00001	5 Digit	00001 ~ 99999

Symbol	Im	Symbol	Im	Symbol	Im	Symbol	Im
J70	9700	O50	14500	R50	17500	U50	20500
M20	12200	P50	15500	S50	18500	V20	21200
N00	13000	Q50	16500	T50	19500	W00	22000

Label Information

PO Number 	XXXXXX (1) 
Supplier Part Number 	SMJD-4253182B-XXN100J70E038ALL (2) 
Bin Code 	J70E038ALL (3) 
Quantity 	XX 
Country of Origin 	XX (4) 
Date Code 	YYYYWW (5) 
Lot Code 	YYMDDXXXXX- XXXXXXXX (6) 
	SEOUL SEMICONDUCTOR CO.,LTD.

Notes

- (1) This is customer's PO Number
- (2) Please refer to SPEC page 2 (30 digit code)
- (3) Please refer to SPEC page 13
- (4) Country of Origin: 2 digit code . For example : Chinese Code: CN
- (5) Date Code : YYYYWW : Packing Date: Year + Week
- (6) Lot Code :
 Initial of manufacture is refer to the 2D code rule.
 YYMDD : Packing Date (Oct. : A, Nov. : B, Dec. : C)
 X : Initial of Manufacturer
 XXXX : Sealing Pack No.
 XXXXXXXX : SSC SAP Code
- (7) It is attached to the top left corner of the box.

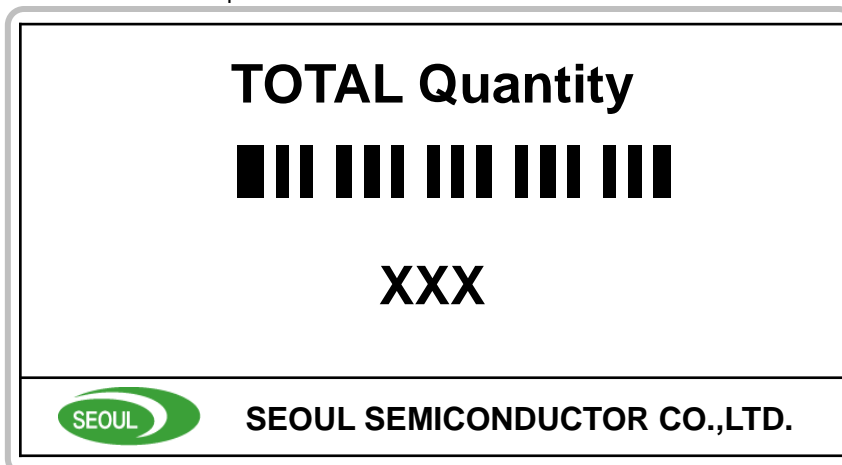
Notes

- (1) It is attached to the bottom right corner of the carton box.

Packaging Specification

1. Tray information

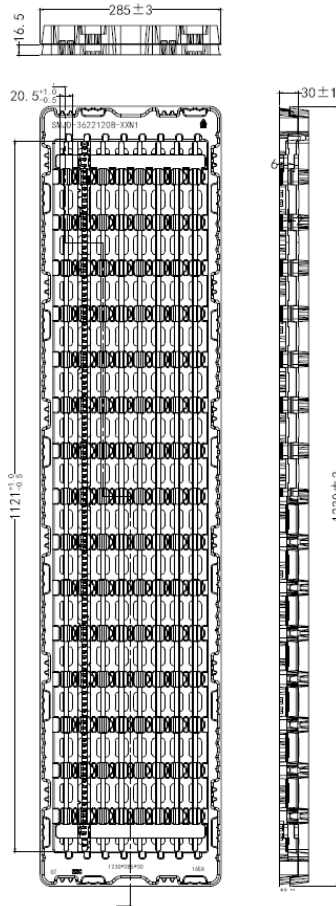

Notes

- (1) Quantity : 16 pcs/Tray
- (2) All dimensions are in millimeters (tolerance : ±0.3)
- (3) Scale none

2. Tray stack and taping

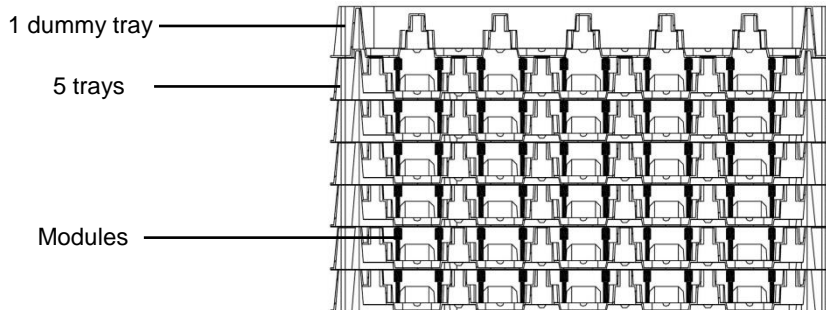

Notes

- (1) 5 trays and additional 1 dummy tray up of box

Packaging Specification

3. Box information & packing

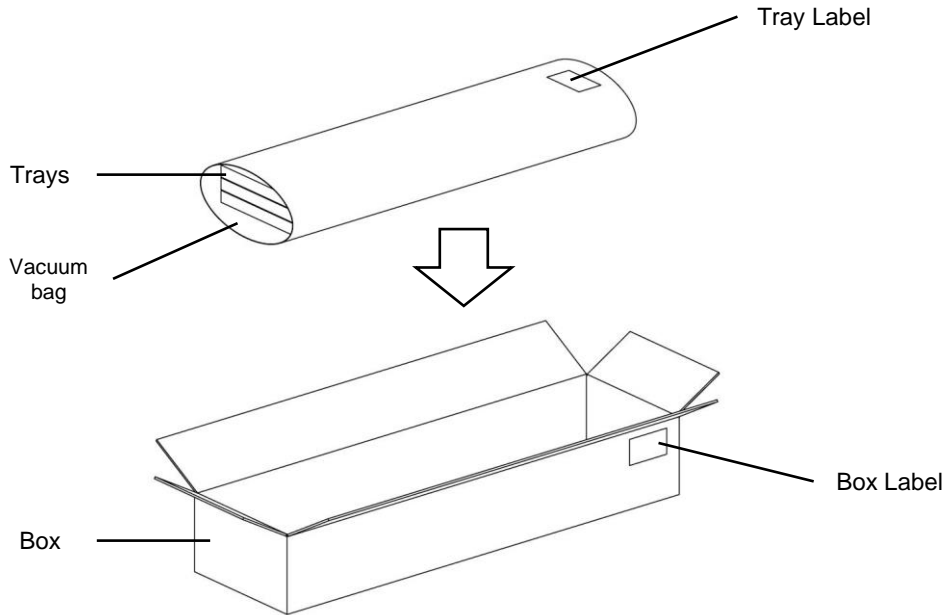

Notes

- (1) Quantity: 5 Tray (80pcs Modules) / Box
- (2) Box size: 1245*300*133

4. Pallet information & packing

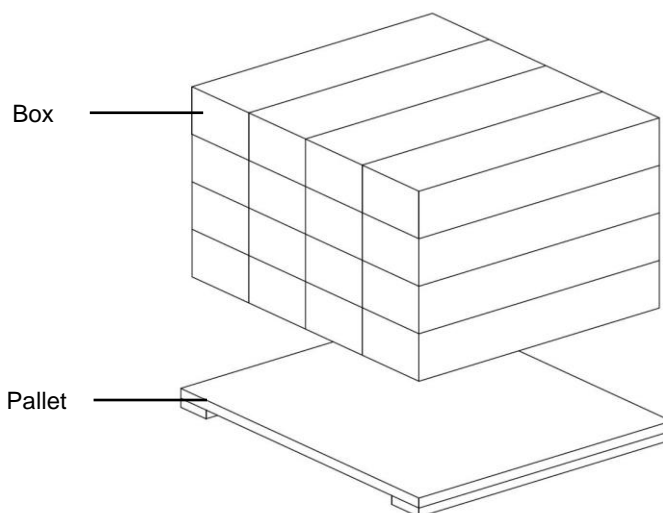

Notes

- (1) Quantity: 1 Pallet = 24 Boxes = 120(24*5) Trays = 1920(120*16) Modules
- (2) Pallet size: 1300*1100 mm

Precaution for Use

- (1) Check the appearance of module before wiring/ assembly, DO NOT use the LED cracked or PCB damaged module.
- (2) The module was designed to be driven with DC source, recognize the polarities of the module was necessity.
- (3) It was SELV module, DO NOT connect the LED directly to main power during wiring.
- (4) DO NOT let the LED packages contacted with any hard matters.
- (5) There was no current regulator built in module, unevenly load between different parallel modules may occur due to the modules V_F variance .
- (6) Please do not use together with the materials containing Sulfur.
- (7) Please do not make any modification on module.

Precaution for Use

(8) LEDs are sensitive to Electro-Static Discharge (ESD) and Electrical Over Stress (EOS).

Below is a list of suggestions that Seoul Semiconductor purposes to minimize these effects.

a. ESD (Electro Static Discharge)

Electrostatic discharge (ESD) is defined as the release of static electricity when two objects come into contact. While most ESD events are considered harmless, it can be an expensive problem in many industrial environments during production and storage. The damage from ESD to an LEDs may cause the product to demonstrate unusual characteristics such as:

- Increase in reverse leakage current lowered turn-on voltage
- Abnormal emissions from the LED at low current

The following recommendations are suggested to help minimize the potential for an ESD event:

One or more recommended work area suggestions:

- Ionizing fan setup
- ESD table/shelf mat made of conductive materials
- ESD safe storage containers

One or more personnel suggestion options:

- Antistatic wrist-strap
- Antistatic material shoes
- Antistatic clothes

Environmental controls

- Humidity control (ESD gets worse in a dry environment)

b. EOS (Electrical Over Stress)

Electrical Over-Stress (EOS) is defined as damage that may occur when an electronic device is subjected to a current or voltage that is beyond the maximum specification limits of the device.

The effects from an EOS event can be noticed through product performance like:

Changes to the performance of the LED package (If the damage is around the bond pad area and since the package is completely encapsulated the package may turn on but flicker show severe performance degradation.)

Changes to the light output of the luminaire from component failure

Components on the board not operating at determined drive power

Failure of performance from entire fixture due to changes in circuit voltage and current across total circuit causing trickle down failures

It is impossible to predict the failure mode of every LED exposed to electrical overstress as the failure modes have been investigated to vary, but there are some common signs that will indicate an EOS event has occurred.

- Damaged may be noticed to the bond wires (appearing similar to a blown fuse).
- Damage to the bond pads located on the emission surface of the LED package (shadowing can be noticed around the bond pads while viewing through a microscope).
- Anomalies noticed in the encapsulation and phosphor around the bond wires.
- This damage usually appears due to the thermal stress produced during the EOS event.

c. To help minimize the damage from an EOS event Seoul Semiconductor recommends utilizing

- qualified LED driver with no big over shoot out put
- Isolated driver that to prevent harmful peaks passed to module.
- A current limiting device

Storage before use

- (1) Do not impact or place pressure on this product because even a small amount of pressure can damage the product. The product should also not be placed in high temperatures, high humidity or direct sunlight since the device is sensitive to these conditions.
- (2) When storing devices for a long period of time before usage, please following these guidelines:
 - * The devices should be stored in the anti-static bag that it was shipped in from Seoul-Semiconductor with opening.
 - * If the anti-static bag has been opened, re-seal preventing air and moisture from being present in the bag.

Guidelines for properly working with Module

- (1) Discharge the lighting system a minimum of 2-3 times prior to working with the module.
- (2) Use only properly rated test equipment and tools for the rated voltage and current of the product being tested.
- (3) It is strongly suggested to wear rubber insulated gloves and rubber bottom shoes.
- (4) Do not wear any conductive items (such as jewelry) which could accidentally contact electric circuits.
- (5) Perform several tests with power off and the lighting system unplugged.
- (6) Faults, lightning, or switching transients can cause voltage surges in excess of the normal ratings.
- (7) Internal component failure can cause excessive voltages.
- (8) Stored or residual electricity in long wire could be hazardous.
- (9) Make sure proper discharge prior to starting work.

Company Information

Published by

Seoul Semiconductor © 2013 All Rights Reserved.

Company Information

Seoul Semiconductor (SeoulSemicon.com) manufactures and packages a wide selection of light emitting diodes (LEDs) for the automotive, general illumination/lighting, appliance, signage and back lighting markets. The company is the world's fifth largest LED supplier, holding more than 10,000 patents globally, while offering a wide range of LED technology and production capacity in areas such as "nPola", deep UV LEDs, "Acrich", the world's first commercially produced AC LED, and "Acrich MJT - Multi-Junction Technology" a proprietary family of high-voltage LEDs. The company's broad product portfolio includes a wide array of package and device choices such as Acrich, high-brightness LEDs, mid-power LEDs, side-view LEDs, through-hole type LED lamps, custom displays, and sensors. The company is vertically integrated from epitaxial growth and chip manufacture in its fully owned subsidiary, Seoul Viosys, through packaged LEDs and LED modules in three Seoul Semiconductor manufacturing facilities. Seoul Viosys also manufactures a wide range of unique deep-UV wavelength devices.

Legal Disclaimer

Information in this document is provided in connection with Seoul Semiconductor products. With respect to any examples or hints given herein, any typical values stated herein and/or any information regarding the application of the device, Seoul Semiconductor hereby disclaims any and all warranties and liabilities of any kind, including without limitation, warranties of non-infringement of intellectual property rights of any third party. The appearance and specifications of the product can be changed to improve the quality and/or performance without notice.

Revision History

Revision	Date	Page	Remarks
Rev0.1	2018-10-10	All	Preliminary data sheet for SMJD-4253182B-XXN1
Rev0.2	2018-10-30	All	Updated the flux
Rev0.3	2018-11-06	All	Added F, G rank
Rev1.0	2018-12-14	4,5,14	Updated performance characteristics, absolute maximum ratings, QR code information
Rev1.1	2018-12-19	14	Updated QR code information
Rev1.0	2019-1-28	15	Updating Label Information