



UVTOP[®] Specification

S-T39A-H1-265-01-1-040

(Formerly UVTOP270TO39HS)

RoHS

SETi		Customer
Drawn	Approval	Approval

Table of Contents:

- 1. Description**
- 2. Mechanical Dimensions**
- 3. Characteristics of S-T39A-H1-265-01-1-040**
- 4. Characteristic Diagrams**
- 5. Labeling**
- 6. Soldering Conditions**
- 7. Precaution for Use**
- 8. Revision History**

Mechanical Dimensions

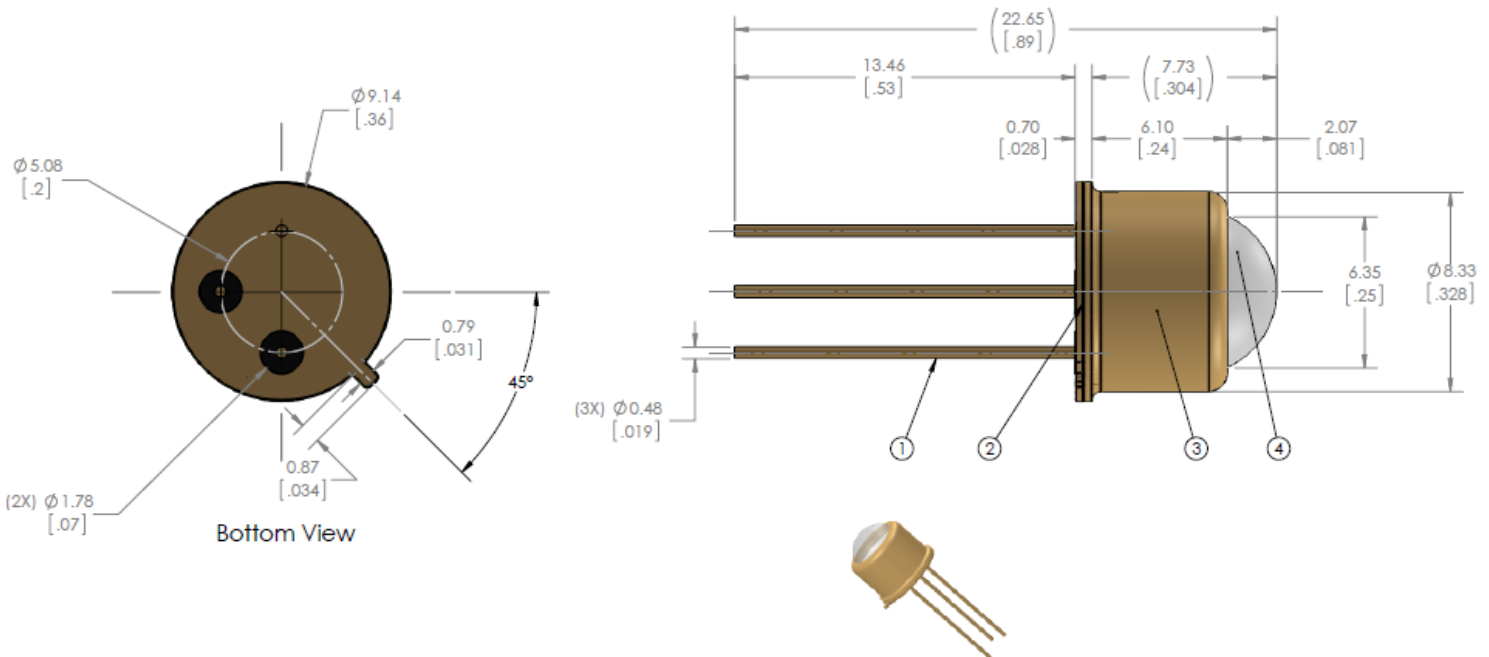

Material Information	
PKG Body	TO39
Lens	Hemispherical

Notes:

- [1] All dimensions in millimeters
- [2] Scale: none
- [3] Undefined tolerance: .XXX = +/- .1

Characteristics of S-T39A-H1-265-01-1-040

1.1 Electro-Optical Characteristics at 20mA

$T_a = 25^\circ\text{C}$, with external heat sink $R_{th}(sp-a)^{[5]} \leq 20^\circ\text{C/W}$, Forward Current=20mA, RH = 30%

Parameter	Symbol	Minimum	Typical	Maximum	Unit
Peak Wavelength ^[1]	λ_p	260		270	nm
Optical Output Power ^[2]	$P_{opt}^{[3]}$	0.4	0.6		mW
Forward Voltage ^[4]	V_F		6.0	7.0	V
FWHM	$\Delta \lambda$		11	14	nm
Viewing Angle	$2\theta_{1/2}$		7		°
Thermal Resistance (T_j-T_{sp})	R_{th}		60		°C/W

1.2 Absolute Maximum Ratings

$T_a = 25$

Parameter	Symbol	Value	Unit
Forward Current	I_F	20	mA
Power Dissipation	P_d	180	mW
Reverse Voltage	V_r	-6	V
Junction Temperature	T_j	60	°C
Storage Temperature	T_{stg}	100	°C

Notes:

[1] Peak wavelength measurement accuracy is ± 2 nm

[2] Optical Output Power measurement accuracy is $\pm 10\%$

[3] P_{opt} is the Optical Output Power as measured with an integrated sphere

[4] Forward voltage measurement accuracy is $\pm 2\%$

[5] $R_{th}(sp-a)$ defined as thermal resistance from solder point to ambient

[6] The exposure to the absolute maximum rated conditions may affect device reliability

[7] The stresses beyond those listed under absolute maximum rating may cause permanent damage to the device

1. Relative Spectral Power Distribution

$T_a = 25\text{ }^\circ\text{C}$, RH=30%

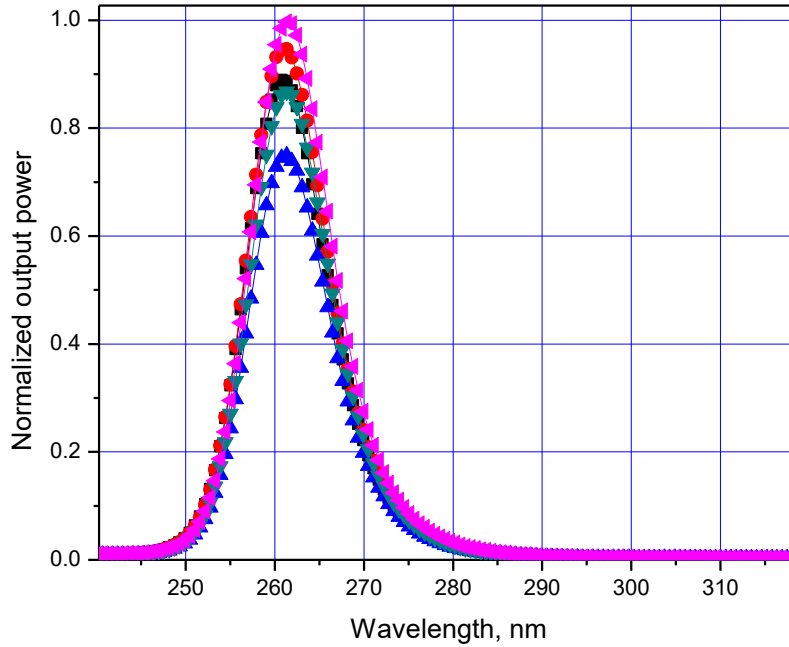

2. Forward Current vs. Forward Voltage

$T_a = 25\text{ }^\circ$

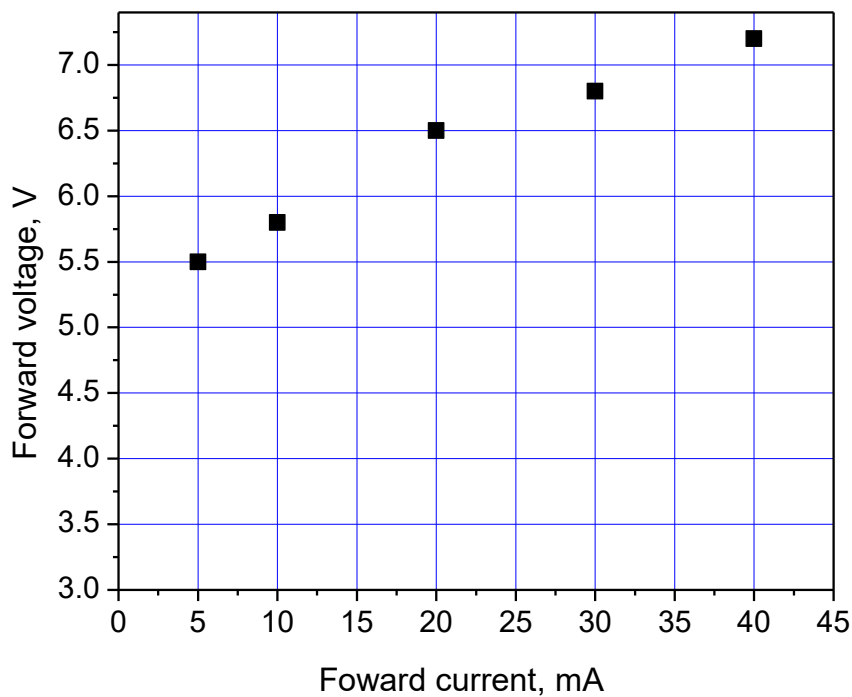

3. Relative Optical Output Power vs. Forward Current

$T_a = 25\text{ }^\circ\text{C}$

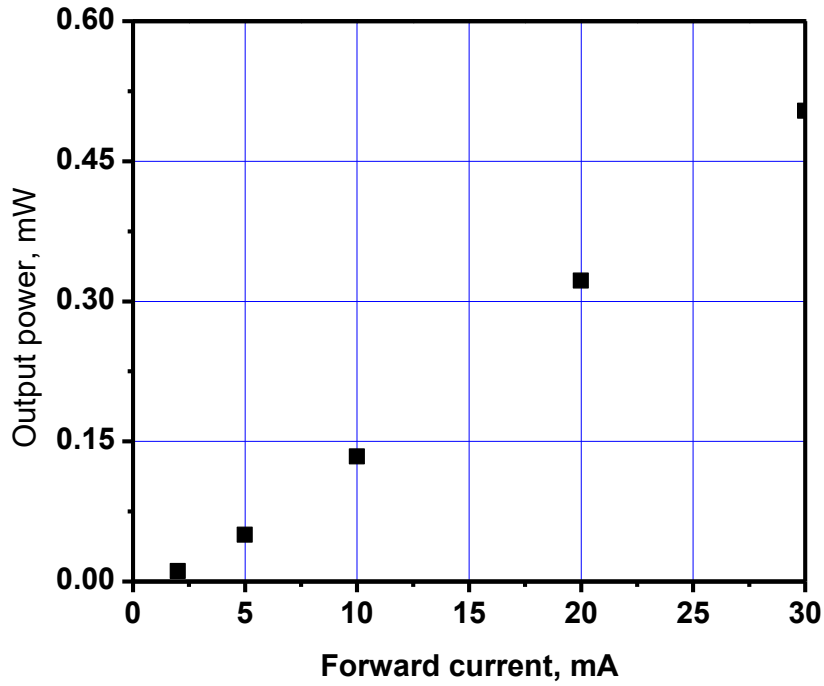

4. Peak Wavelength vs. Forward Current

$T_a = 25\text{ }^\circ\text{C}$

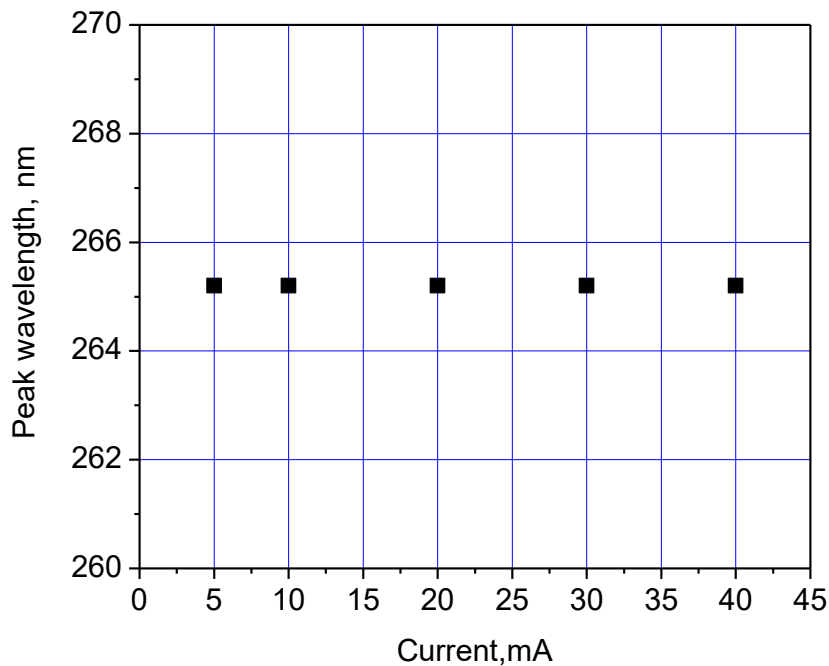

5. Forward Voltage vs. Ambient Temperature

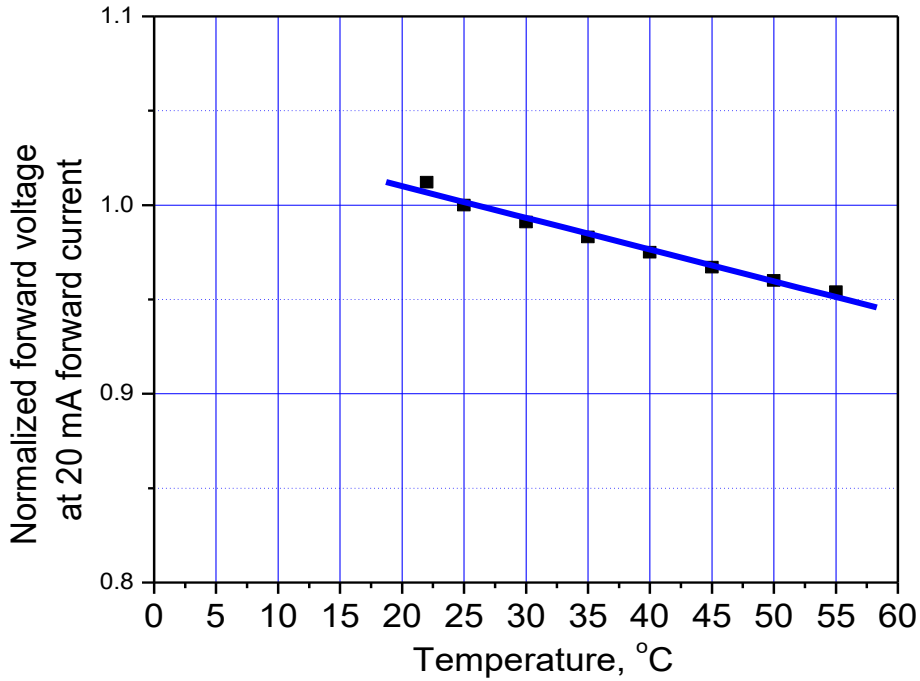

6. Typical Angular Diagram

$I_f=20\text{mA}$

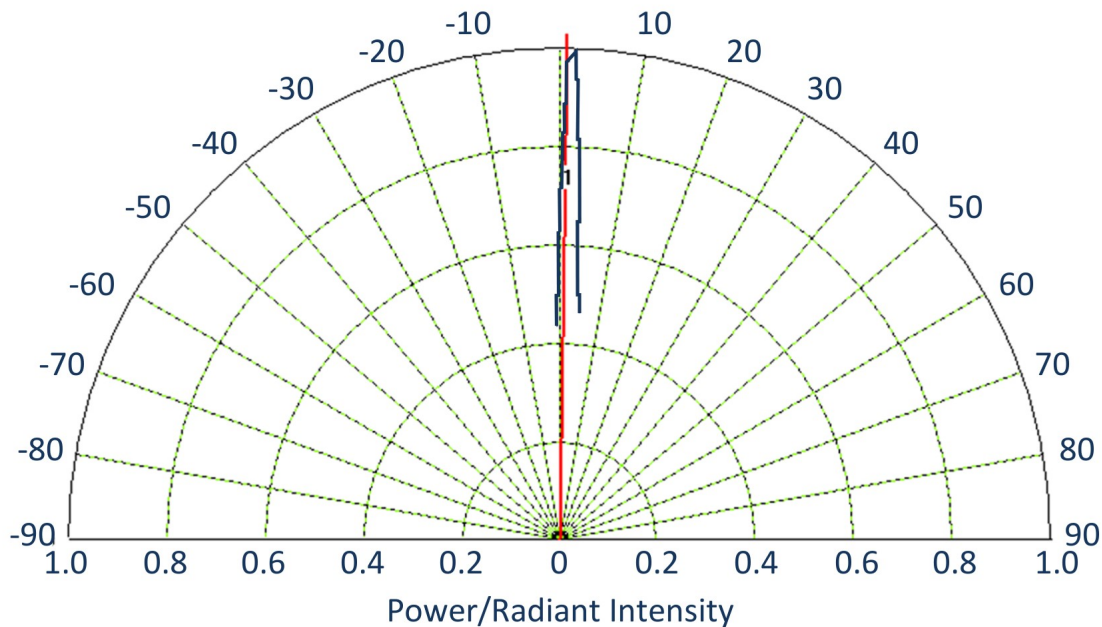

Solder no closer than 3mm from the base of the header.

Following conditions must be avoided during soldering: overheating, ESD, mechanical shock, vibration, ultrasonic shock, mechanical damage and contamination.

- Only solder to the package leads. Soldering to the LED header or the cap will result in damage to the device.
- If clamping the LED is required, mechanical stress on the LED should be minimized.
- Mechanical stress, shock and vibration must be avoided during soldering.
- Do not mount the LED directly on the PCB or heat sink by soldering directly to the LED header or cap.
- Only use non-corrosive flux.
- Only cut device leads at room temperature using an ESD protected tool. Do not apply stress to the leads while hot.
- Do not apply current to the device until it has cooled down to room temperature after soldering.
- When forming leads, the leads should be bent at a point at least 3mm from the base of the header.
- Form leads prior to soldering.
- Do not use header or can of LED to form leads.

Recommended Soldering Conditions

Dip Soldering		Hand Soldering	
Pre-Heat Time	30 seconds, max.	Temperature at Solder Point	190° C
Solder Bath Temperature	190° C	Soldering Time	5 seconds, max.
Dipping Time	5 seconds, max.		

The above table contains the maximum specifications for the soldering conditions. However, it is recommended that soldering always be performed at the lowest possible temperature.

Cleaning

Cleaning with isopropyl alcohol is recommended. Propanol and ethyl alcohol may also be used. DO NOT USE acetone, chloroform, trichloroethylene, or MKS to clean the LEDs.

Do not use ultrasonic cleaners with the LEDs.

UV Light

These devices are ultraviolet LEDs. During operation, the LED emits high intensity ultraviolet (UV) light, which is harmful to skin and eyes.

UV light is hazardous to skin and may cause cancer. Avoid exposure to UV light when LED is operational.

Precautions must be taken to avoid looking directly at the UV light without the use of UV light protective glasses. Do not look directly at the front of the LED or at the LED's lens when LED is operational.

Attach the following warning labels on products/systems that use UV LEDs.



Static Electricity

These products are ESD (electrostatic discharge) sensitive; static electricity and surge voltages seriously damage UV LEDs and can result in complete failure of the device. Precautions must be taken against ESD when handling or operating these devices.

Operating Conditions

In order to ensure the correct functioning of these LEDs, compliance to the maximum electrical specifications is paramount. These LEDs are particularly sensitive to any current value that exceeds the absolute maximum rating of the product. Any applied current in excess of the maximum specification will cause damage and possible complete failure of the product.

The current flowing in a LED is an exponential function of the voltage across it. A small change in voltage can produce a very large change in current and lead to complete failure of the LED. The use of current regulated drive circuits are recommended for these products.

Any attempt to drive these UV LEDs with a voltage source instead of a current source will cause damage and possible complete failure of the product.

These LEDs are susceptible to heat generation. Use care to design end product with adequate thermal management to ensure that LEDs do not exceed maximum recommended temperatures. Operating LEDs at temperatures in excess of specification will result in damage and possible complete failure of the product.

Revision History

Revision	Change Date	Authorized Signature
01	April 28, 2016	