

810W, 200-400Vac Input, Non-isolated LED Driver

Product Datasheet



The global certified SLK-810-C is a non-isolated extremely wide input smart LED driver. 10kV surge protection level, 100khour long life provide high confidence to luminaire users. It supports not only traditional 4-in-1 control, but also DALI2.0 and other protocols. NFC and cable programming are both available. All around protections including digital OTP (internal and external by NTC) with auto-recovery secure 24hour non-stop operation for luminaires.

- Horticultural Stadium Flood Harbor UV Fishing



- Features 2
- Model List 2
- Technical Data 3
- Safety/EMC Compliance 4
- Dimming 4
- Programming 6
- Lifetime vs. Case Temperature 8
- Power Factor vs. Load 8
- THD vs. Load 9
- Efficiency vs. Load 9
- Inrush Current 10
- Dielectric Strength 10
- Tc Point 10
- Packaging Information 11
- Mechanical Design 12
- Output Operation Range 15

SLK-810-C

■ Features

- Absolute Supply Voltage: 180-440Vac
- 97% Efficiency Max.
- **Non-isolated Design**
- **Output Cable with Ground Wire (Optional)**
- Low Inrush Current
- 100,000Hour Life @ Tc=75°C
- Airset™ NFC Programmability
- +/-2% Output Current Accuracy
- Isolated 0-10V/PWM/Time/DALI2.0 Dimmable
- **Glow-free Dim Off**
- 12V 300mA Auxiliary Power to Power Controllers and Fans
- UL Class P, ENEC/CB/RCM
- Safety according to UL8750, EN 61347-1, 61347-2-13, 62384

■ Model List

Model Number	Input Voltage Range	Output Power	Output Voltage	Full Power Settable Current Min	Full Power Settable Current Max
SLK-810-C220-XYZ	180~440Vac	810 W	221-500Vdc	1.6A	2.2A
SLK-810-C280-XYZ	180~440Vac	810 W	174-368Vdc	2.2A	2.8A
SLK-810-C320-XYZ	180~440Vac	810 W	152-289Vdc	2.8A	3.2A

XY=	Dimming Method	Programmable	12Vaux	Dim-off
EN	0-10V/PWM/Time/Resistor	Cable	300mA	√
ER	0-10V/PWM/Time/Resistor	NFC Wireless	300mA	√
AR	DALI2.0	NFC Wireless	-	√
MR	RDM + DMX	NFC Wireless	-	√

Z=	U	V	S	W	D
Input Cable	3 pin UL cable with ground	3 pin UL cable with ground	3 pin VDE cable with ground	3 pin VDE cable with ground	2 pin VDE cable without ground
Output Cable	2 pin UL cable without ground	3 pin UL cable with ground	2 pin VDE cable without ground	3 pin VDE cable with ground	2 pin VDE cable without ground
Certified with	UL Listed Class P FCC 200-400Vac	UL Listed Class P FCC 200-400Vac	ENEC CB RCM Class I 220-400Vac	ENEC CB RCM Class I 220-400Vac	Class II 220-400Vac

■ Technical Data

Input Voltage	180~440Vac
Input Frequency	47~63Hz
Power Factor	>0.9@60-100%load, refer to PF vs. Load curve
THD	<15%@60-100%load, refer to THD vs. Load curve
Input Current	3.1Amax@277Vac & Full-Load 2.3Amax@380Vac & Full-Load
Inrush Current	See Inrush Current Section in the datasheet
Leakage Current	0.75MIU max @347Vac 60Hz, UL8750 0.7mA max @400Vac 50/60Hz, IEC60598-1
Input Under Voltage	Shut down and auto-restart
Surge Protection	Line to line 6kV, line to ground 10kV, IEC 61000-4-5
Current Accuracy	±2%Io
Ripple Current	Ip-p:5%Io max
Setup Time	1.5s max
Overshoot	10% Io max & LED Load
Output Over Voltage	110% Vomax, typ.
Short Circuit	Auto recovery. The output recovers when short is removed.
Over Temperature	Lower the output current when $T_c \geq 105 \pm 10^\circ\text{C}$; Auto Recovery When $T_c \leq 70 \pm 10^\circ\text{C}$
Auxiliary Power (Vaux)	12V+/-5%, 300mA max
Operating Temperature	Case Temperature $T_c = -40^\circ\text{C} \sim +90^\circ\text{C}$; 10%RH~100%RH
Storage Temperature	$-40^\circ\text{C} \sim +85^\circ\text{C}$; 5%RH~100%RH
MTBF	$\geq 320,000$ hours, 75°C case temperature (MIL-HDBK-217F)
Lifetime	$\geq 100,000$ hours, 75°C case temperature, refer to life vs. T_c curve
Case Temperature	90°C max, marked in the T_c point of label
Dimension	270 x 90 x 41.5 by mm (body), 297 x 90 x 41.5 by mm (endcaps included)
Net Weight	1900g
Packing	See Package Information Section in the datasheet

Notes: Unless specified, all the test results are measured in 25°C room temperature.

■ Safety/EMC Compliance

Safety Standards	Description
UL8750	Light emitting diode(LED) equipment for use in lighting products
UL1012	Power units other than class 2
IEC 61347-1	Lamp control gear Part 1: general and safety requirements
IEC 61347-2-13	Lamp control gear Part 2-13: particular requirement for d.c. or a.c. supplied electronic control gear for LED modules
IEC 62384	DC or AC supplied electronic control gear for LED modules - Performance requirements
EMC Standards	Description
IEC 55015	Conducted emission test & radiated emission test
IEC 61000-3-2	Harmonic current emissions; Class C
IEC 61000-3-3	Voltage fluctuations & flicker
FCC Part 15	ANSI C63.4:2009 Class B
IEC 61000-4-2	Electrostatic discharge (ESD): 8 kV air discharge, 4 kV contact discharge
IEC 61000-4-3	Radio frequency electromagnetic field susceptibility test (RS)
IEC 61000-4-4	Electrical fast transient (EFT)
IEC 61000-4-5	Surge immunity test
IEC 61000-4-6	Conducted radio frequency disturbances test (CS)
IEC 61000-4-8	Power frequency magnetic field test
IEC 61000-4-11	Voltage dips
IEC 61547	Electromagnetic immunity requirements applies to lighting equipment

■ Dimming

Parameter	Min.	Typ.	Max.
Vdim Sourcing Current	100uA	150uA	200uA
Vdim Allowed Input Voltage	-20 V		20 V
0-10V Dimming Range	10% (Vdim=1V)	Linear	100% (Vdim=9~10V)
PWM Dimming Range	10% (Duty=10%)	Linear	100% (Duty=90-100%)
Dim off threshold	0.4V or 4%	0.5V or 5%	0.6V or 6%
Dim on threshold	0.6V or 6%	0.7V or 7%	0.8V or 8%
PWM High	3.8V		10V
PWM Low	0V		0.6V
PWM Frequency	300Hz		2kHz
PWM Controller Capability	300uA		
DALI Interface Standard	IEC62386, part 101,102,207		
DA1,DA2 High Level	9.5	16	22.5
DA1,DA2 Low Level	-6.5	0	6.5
DA1,DA2 Current	0		2mA
DMX+ & DMX- Voltage	-6V		6V
DMX to Ground Resistance	25Mohm		
Logic 0/1 (DMX+ to DMX-) Threshold		0.2V	
Communication Baud Rate		250kbps	

SLK-810-C

- **Default Dimming Curves**
 - a. **0-10V dimming without dim-off**

0-10V Dimming Curve

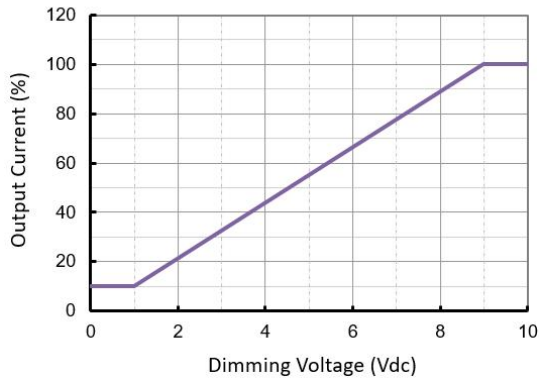

PWM Dimming Curve

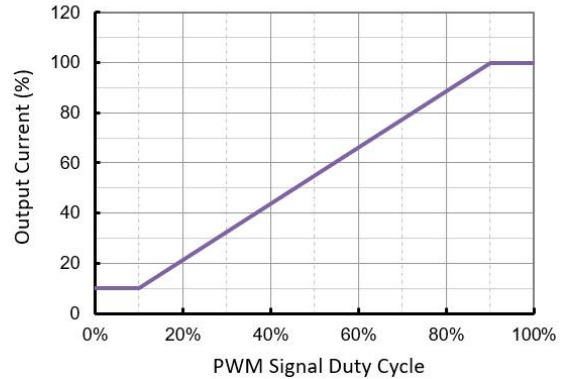

- b. **0-10V dimming with dim-off**

0-10V Dimming Curve
with Dim Off

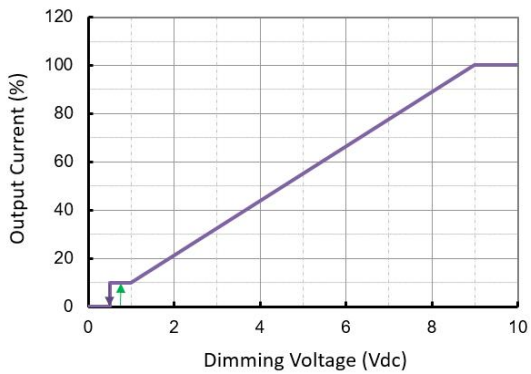

PWM Dimming Curve

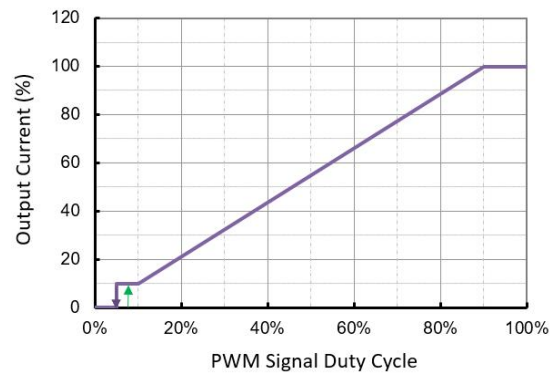

- c. **DALI and DMX dimming curves**

DALI Dimming Curve

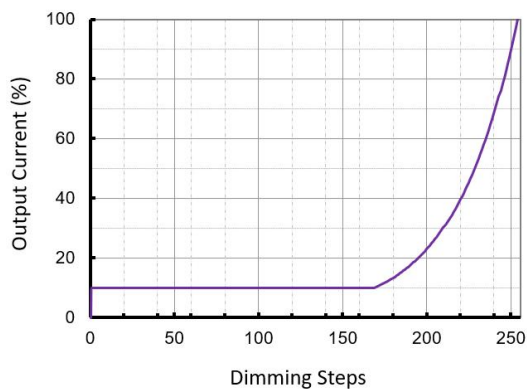

DMX/RDM Dimming Curve

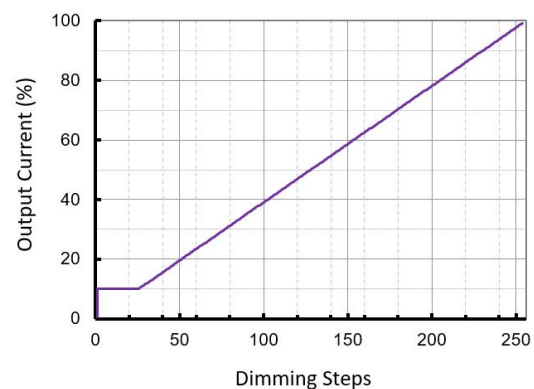

Note: Both DALI and DMX dimming curves can be customized to be linear or logarithmic as default.

■ Programming

- NFC Programming by PC/Laptop



- Download PC software setup program at <https://www.upowertek.com/download-2/>
- Click uPowertek_Programming_UTILITY_Vx_Setup.exe to install the software.
- Open the software by windows Start Menu.

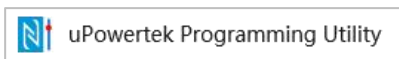

- The GUI start and choose the right NFC programmer.

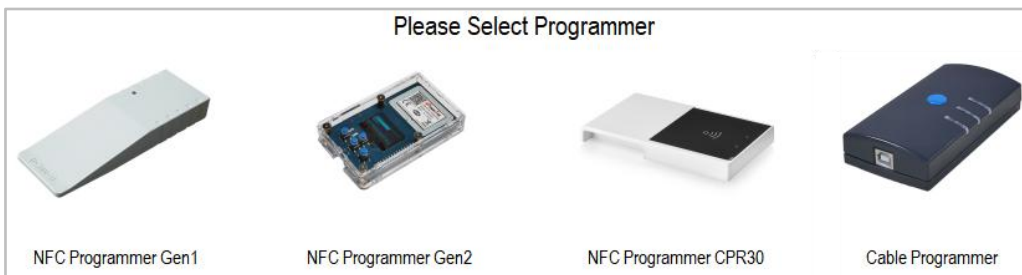

- When the interface below appears, you can start programming.

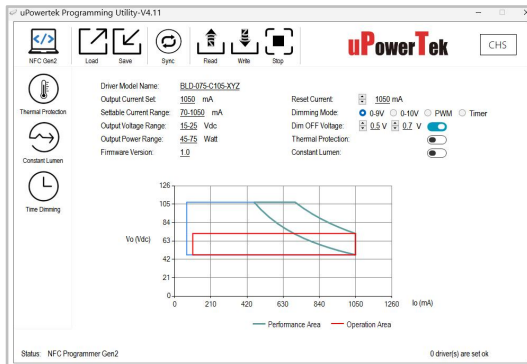

- NFC Programming by Smartphone

- Download Android APP at <https://www.upowertek.com/download-2/> or search IOS app “uPowerTek” from Apple’s app store.
- The cellphone should have NFC function and make sure it is enabled. The link below shows how to turn on the NFC from either iPhone or Android phones.
<https://www.upowertek.com/how-to-use-nfc-on-cellphone/>
- Open the APP by icon below.



- **Cable Programming**



- a. Download PC software setup program at <https://www.upowertek.com/download-2/>
- b. Click uPowertek_Programming_Utility_Vx_Setup.exe to install the software.
- c. Open the software by windows Start Menu.

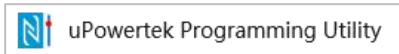

- d. The GUI start and choose the last Cable Programmer.

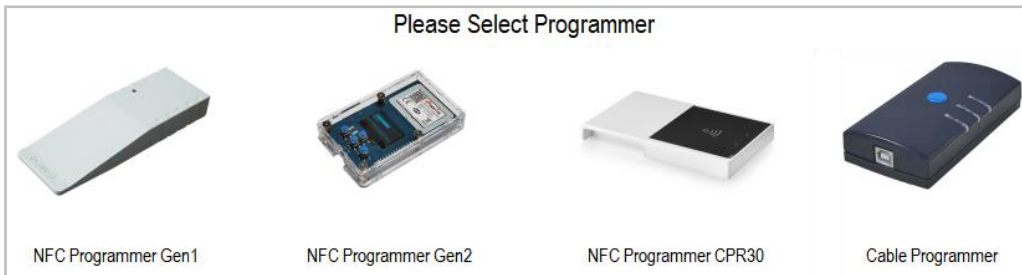

- e. When the interface below appears, you can start programming.

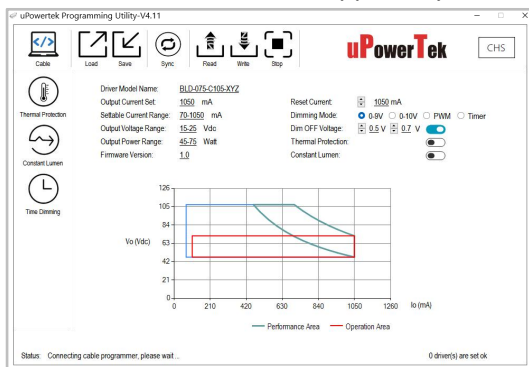

- a. Connect the Vdim+ and Vdim- wires to the right ones (the same color) of the programmer.

- **Please contact with us for programming user manual and more information such as:**

- a. Output Lumen Compensation
- b. Luminaire Thermal Protection by External NTC (with extra cable)
- c. Dimming Curve Customization (dim off threshold, minimum dimming level, maximum dimming voltage etc.)
- d. Adjustable Startup Time
- e. Time Dimming (adaptive mid-night, percentage, etc.)
- f. Customized Control Protocol

■ Lifetime vs. Case Temperature

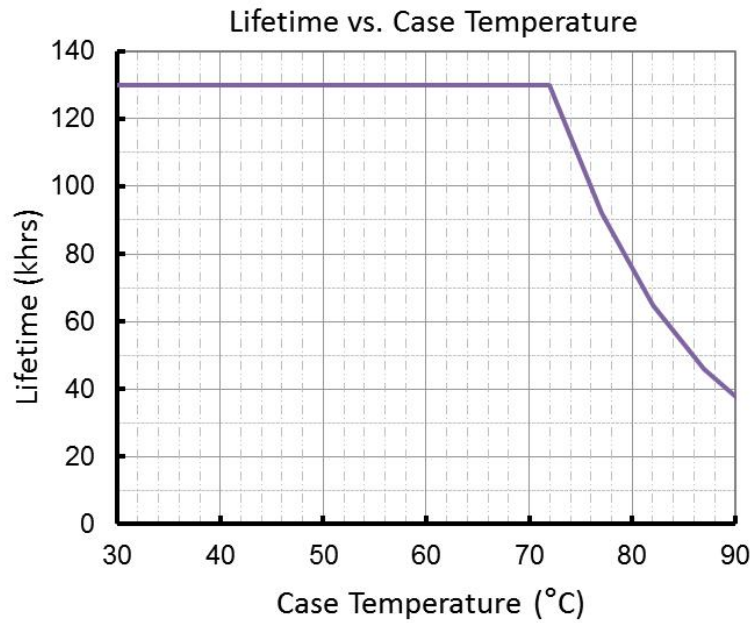

(End of Life: Maximum Failure Rate=10%)

■ Power Factor vs. Load

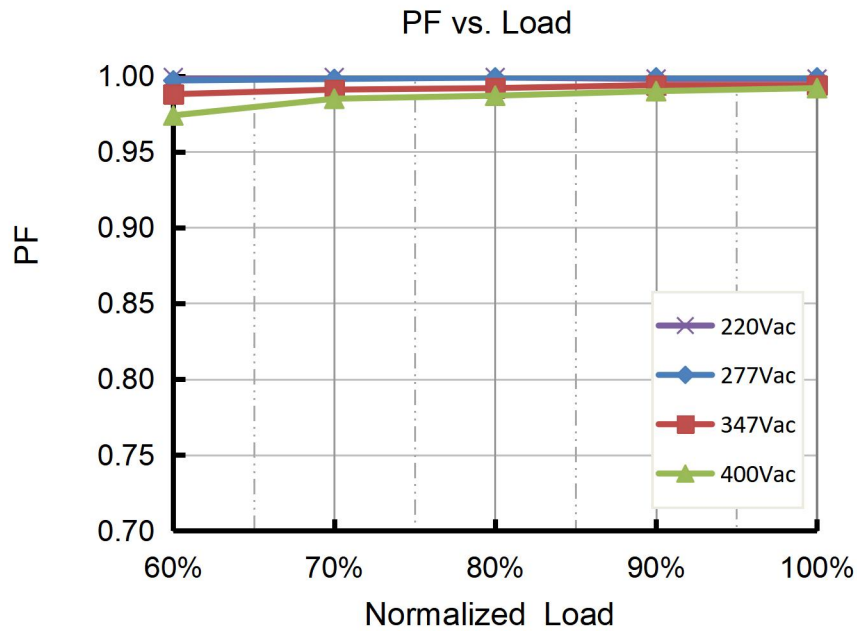

■ THD vs. Load

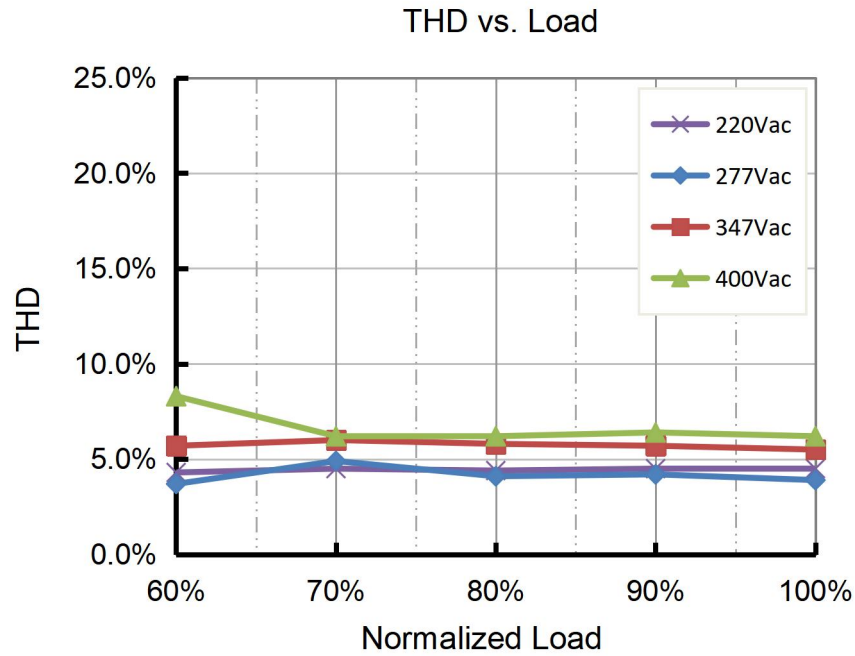

■ Efficiency vs. Load

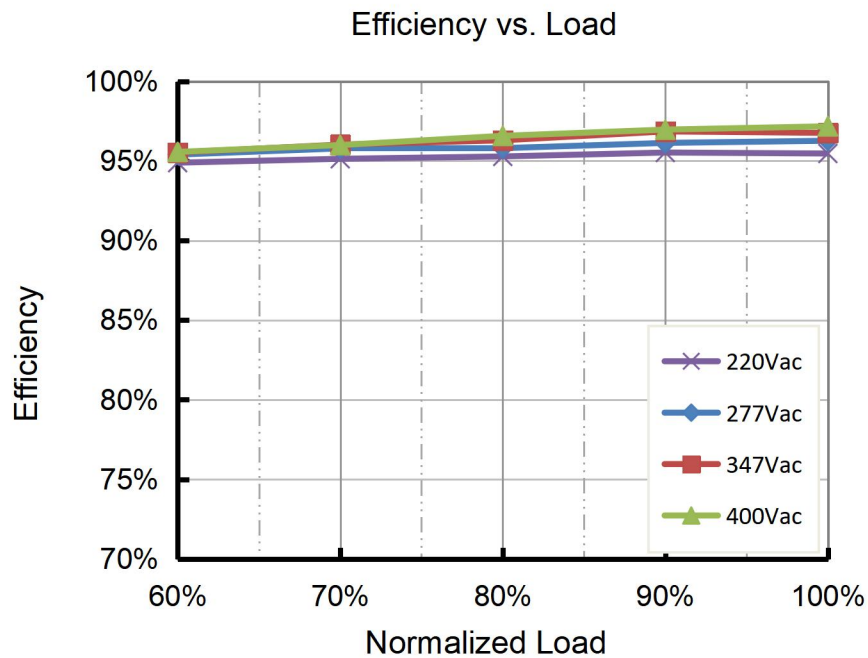

Inrush Current

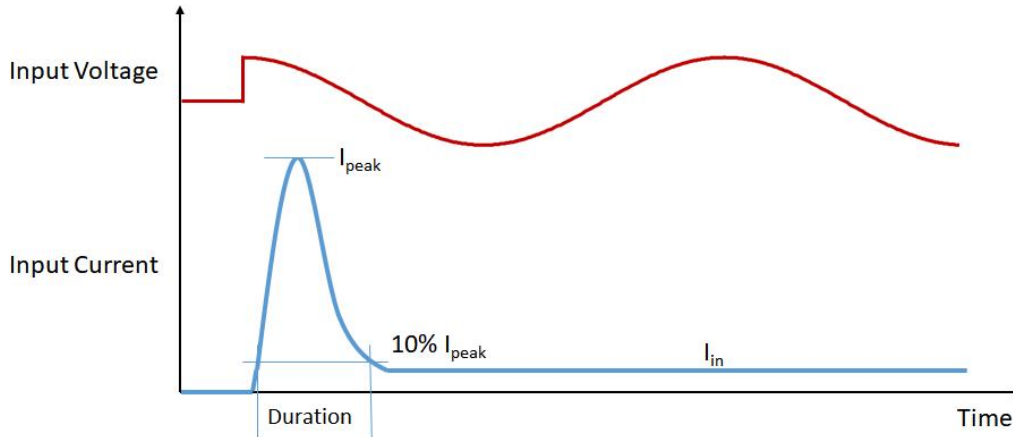

Input Voltage	I_{peak}	Duration
277Vac	7.1A	19.3mS
347Vac	10.5A	14.1mS
400Vac	13.3A	15.4mS

Please contact with us for MCB calculation and waveforms.

Dielectric Strength

Unit: Vac	Input	Output	Dimming	Case
Input	-	-	3920	1960
Output	-	-	3920	1960
Dimming	3920	3920	-	1960
Case	1960	1960	1960	-

Tc Point

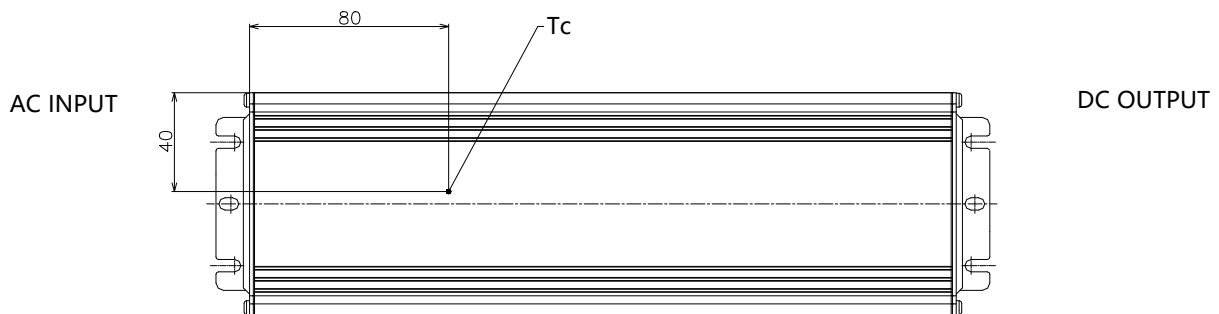

■ Packaging Information

Typical Carton Dimension(L×W×H)	490×370×125 mm
Positioning plate	2pcs/carton
Shield Board	1pcs/carton
LED Drivers/LED	6pcs/carton
Net Weight	11.4 kg/carton
Gross Weight	12.4 kg/carton

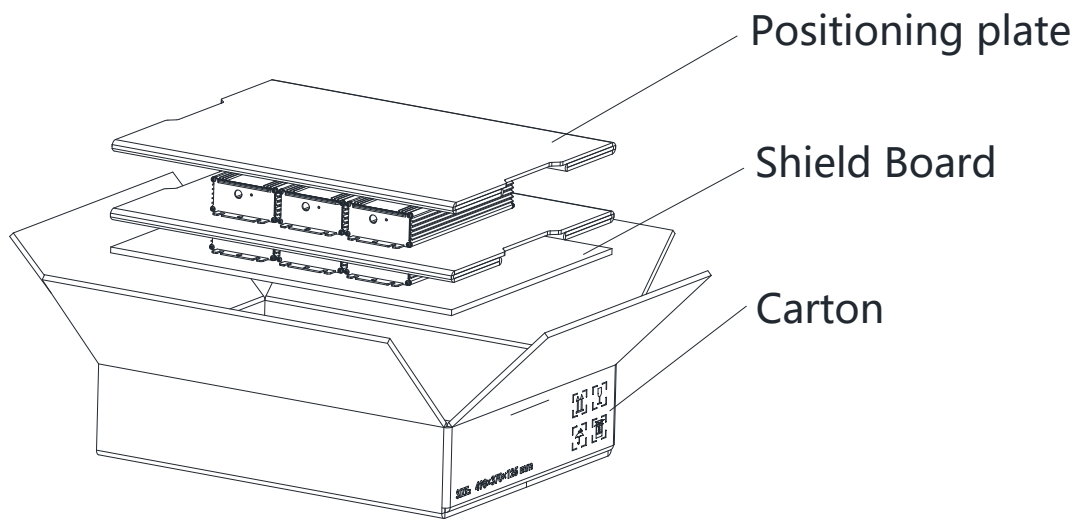

SLK-810-C

- SLK-810-Cxxx-ARS (VDE Cable)

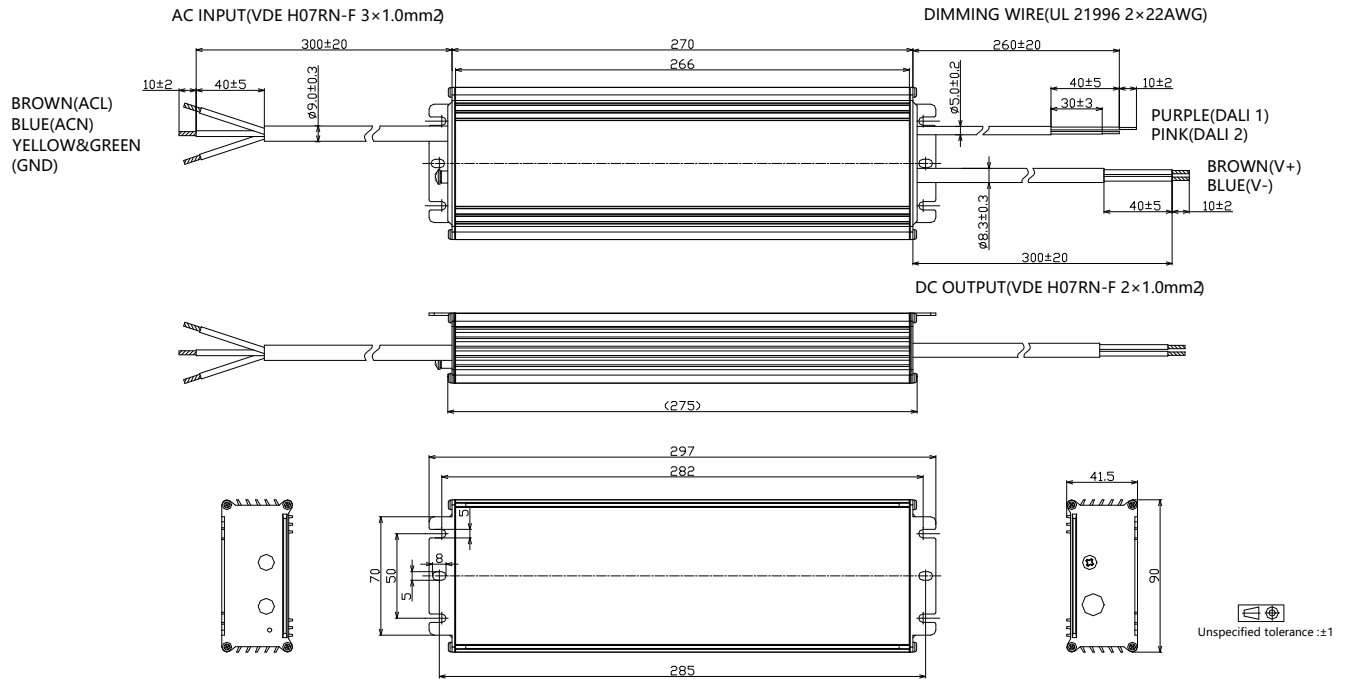

- SLK-810-Cxxx-MRS (VDE Cable)

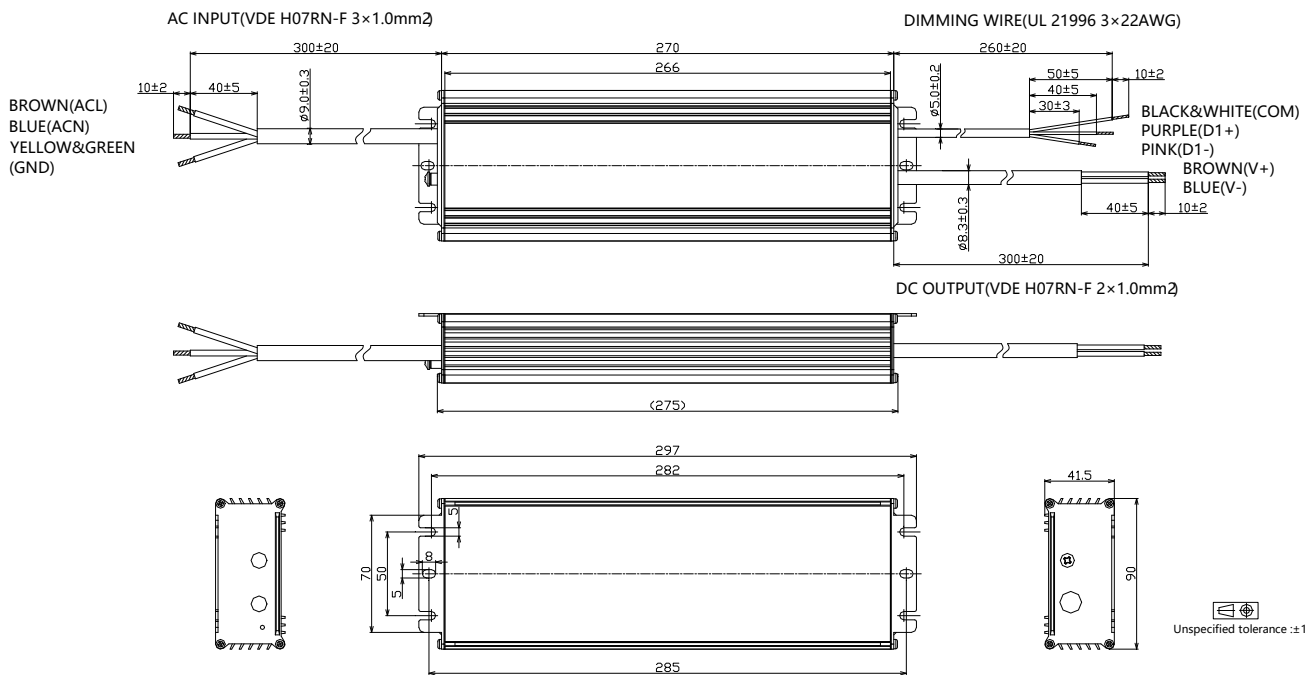

■ Output Operation Range

Model	Typical Set Output Current (mA)	Max Output Power (W)	Output Voltage Min (V)	Output Voltage Max(V)	Minimum Dimming Current (mA)
-C220	2200	810	221	368	220
	2100	810	231	386	210
	2000	810	243	405	200
	1900	810	256	426	190
	1800	810	270	450	180
	1700	810	286	476	170
	1600	810	300	500	160
	1500	750	300	500	160
	1400	700	300	500	160
	1300	650	300	500	160
	1200	600	300	500	160
	1100	550	300	500	160

	160	80	300	500	160

Model	Typical Set Output Current (mA)	Max Output Power (W)	Output Voltage Min (V)	Output Voltage Max(V)	Minimum Dimming Current (mA)
-C280	2800	810	174	289	280
	2700	810	180	300	270
	2600	810	187	312	260
	2500	810	194	324	250
	2400	810	203	338	240
	2300	810	211	352	230
	2200	810	221	368	220
	2100	773	221	368	220
	2000	736	221	368	220
	1900	700	221	368	220
	1800	663	221	368	220
	1700	626	221	368	220

	220	81	221	368	220

SLK-810-C

Model	Typical Set Output Current (mA)	Max Output Power (W)	Output Voltage Min (V)	Output Voltage Max(V)	Minimum Dimming Current (mA)
-C320	3200	810	152	253	320
	3100	810	157	261	310
	3000	810	162	270	300
	2900	810	168	279	290
	2800	810	174	289	280
	2700	781	174	289	280
	2600	752	174	289	280
	2500	723	174	289	280
	2400	694	174	289	280
	2300	665	174	289	280
	2200	636	174	289	280
	2100	608	174	289	280

	280	81	174	289	280