

Long Life High Quality Driver

800W | 200-480Vac Input

■ Features

- Absolute Supply Voltage: 180-528Vac or 250-740Vdc
- Great Surge Immunity 10kV
- 96% Efficiency max.
- Low Inrush Current
- 100,000Hour Life @ Tc=75°C
- NFC Programmability and Isolated Dimming
- +/-2% Output Current Accuracy (Programmable Model)
- 0-10V/PWM/Time/DALI /DMX (Optional) Dimmable
- 12V 300mA Auxiliary Power to Power Controllers and Fans
- UL Class P, ENEC/CB/CCC SELV Output
- Safety according to EN 61347-1, 61347-2-3, 61347-2-13, 62384



■ Model List (See appendix for more details about the operation range)

Model Number	Input Voltage Range	Output Power	Output Voltage	Full Power Settable Current Min	Full Power Settable Current Max	Certification
TLD-800-C18A-XYU	180-528Vac	800 W	30-56Vdc	14.5A	18A	UL/FCC
TLD-800-C860-XYU	180-528Vac	800 W	56-133Vdc	6A	8.6A	UL/FCC
TLD-800-C600-XYU	180-528Vac	800 W	80-190Vdc	4.2A	6A	UL/FCC
TLD-800-C420-XYU	180-528Vac	800 W	114-222Vdc	3.6A	4.2A	UL/FCC
TLD-800-C18A -XYS	180-528Vac	800 W	30-56Vdc	14.5A	18A	CB/ENEC/CCC
TLD-800-C860-XYS	180-528Vac	800 W	56-133Vdc	6A	8.6A	CB/ENEC/CCC
TLD-800-C600-XYS	180-528Vac	800 W	80-190Vdc	4.2A	6A	CB/ENEC/CCC
TLD-800-C420-XYS	180-528Vac	800 W	114-222Vdc	3.6A	4.2A	CB/ENEC/CCC

XY=	Dimming Method	Programmable	12Vaux	Dim-off
NN	-	-	-	-
DN	0-10V	Cable	-	No Dim-off as default status, programmed to have Dim-off
EN	0-10V	Cable	300mA	√
TR	Time/Set Current	NFC Wireless	-	-
DR	0-10V	NFC Wireless	-	No Dim-off as default status, programmed to have Dim-off
ER	0-10V/PWM/Time	NFC Wireless	300mA	√
AR	DALI	NFC Wireless	-	√

■ Technical Data

Input Voltage	180-528Vac or 250-740Vdc
Input Frequency	47~63Hz
Power Factor	>0.9@60-100%load, refer to PF vs. Load curve
THD	<15%@60-100%load, refer to THD vs. Load curve
Input Current	3.5Amax@277Vac & Full-Load, 2Amax@480Vac & Full-Load
Inrush Current	15A peak,3.2ms duration, <0.25A2s@277Vac, Cold Start 20A peak,3.3ms duration, <0.5A2s@480Vac, Cold Start
Leakage Current	1mA max @277Vac 60Hz, UL8750,0.75mA max @220Vac 50Hz, IEC61347-1
Input Under Voltage	Shut down and auto-restart
Surge Protection	Line to line 6kV, line to ground 10kV, IEC 61000-4-5
Current Accuracy	±5%lo for non programmable models, ±2%lo for programmable models
Ripple Current	Ip-p:5%lo max
Setup Time	1.2s max
Overshoot	10% Io max & LED Load
Output Over Voltage	110% Vomax, typ.
Short Circuit	Auto recovery. The output recovers when short is removed.
Over Temperature	Lower the output current when $T_c \geq 105 \pm 10^\circ\text{C}$; Auto Recovery When $T_c \leq 70 \pm 10^\circ\text{C}$
Auxiliary Power (Vaux)	12V+/-5%, 300mA max
Operating Temperature	Case Temperature $T_c = -40^\circ\text{C} \sim +90^\circ\text{C}$; 10%RH~100%RH
Storage Temperature	$-40^\circ\text{C} \sim +85^\circ\text{C}$; 5%RH~100%RH
MTBF	$\geq 320,000$ hours, 75°C case temperature (MIL-HDBK-217F)
Lifetime	$\geq 100,000$ hours, 75°C case temperature, refer to life vs. T_c curve
Case Temperature	90°C max, marked in the T_c point of label
Dimensions	9.33x4.92x1.93 by inch (body), 10.3x4.92x1.93 by inch (endcaps included) 237 x 125 x 49 by mm (body), 262 x 125 x 49 by mm (endcaps included)
Net Weight	2600g
Packing	8pcs/Cartron/22.8kg, 490 x 370 x 250 by mm

Notes: Unless specified, all the test results are measured in 25°C room temperature.

■ Safety/EMC Compliance

Safety Standard	Description
UL8750	Light emitting diode(LED) equipment for use in lighting products
UL1012	Power units other than class 2
IEC 61347-1	Lamp control gear Part 1: general and safety requirements
IEC 61347-2-13	Lamp control gear Part 2-13: particular requirement for d.c. or a.c. supplied electronic control gear for LED modules
EMI Standards	Description
IEC 55015	Conducted emission test & radiated emission test
IEC 61000-3-2	Harmonic current emissions; Class C
IEC 61000-3-3	Voltage fluctuations & flicker
FCC Part 15	ANSI C63.4:2009 Class B
EMS Standards	Description
IEC 61000-4-2	Electrostatic discharge (ESD): 8 kV air discharge, 4 kV contact discharge
IEC 61000-4-3	Radio frequency electromagnetic field susceptibility test (RS)
IEC 61000-4-4	Electrical fast transient (EFT)
IEC 61000-4-5	Surge immunity test
IEC 61000-4-6	Conducted radio frequency disturbances test (CS)
IEC 61000-4-8	Power frequency magnetic field test
IEC 61000-4-11	Voltage dips
IEC 61547	Electromagnetic immunity requirements applies to lighting equipment

■ Dimming

Parameter	Min.	Typ.	Max.
Vdim Sourcing Current	200uA	300uA	450uA
Vdim Allowed Input Voltage	-20 V		20 V
0-10V Dimming Range	10% (Vdim=1V)	Linear	100% (Vdim=9~10V)
PWM Dimming Range	10% (Duty=10%)	Linear	100% (Duty=90-100%)
Dim off threshold	0.4V or 4%	0.5V or 5%	0.6V or 6%
Dim on threshold	0.6V or 6%	0.7V or 7%	0.8V or 8%
PWM High	3.8V		10V
PWM Low	0V		0.6V
PWM Frequency	300Hz		2kHz
External PWM Controller Current Sinking Capability	300uA		
DALI Interface Standard		IEC62386	
DA1,DA2 High Level	9.5	16	22.5
DA1,DA2 Low Level	-6.5	0	6.5
DA1,DA2 Current	0		2mA

- Dimming Curve

a. Without dim-off

0-10V Dimming Curve

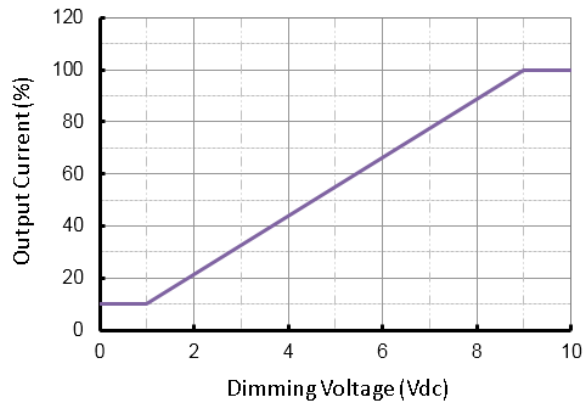

PWM Dimming Curve

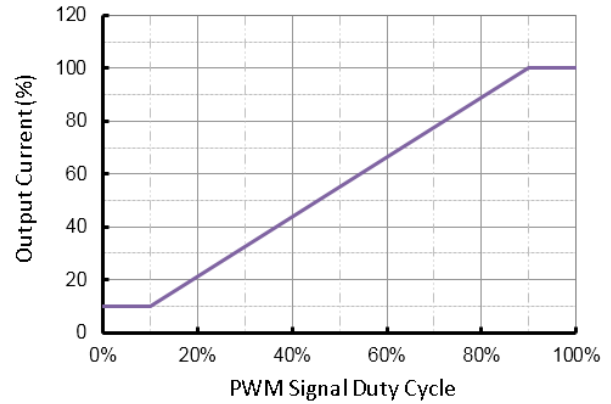

b. With dim-off

0-10V Dimming Curve

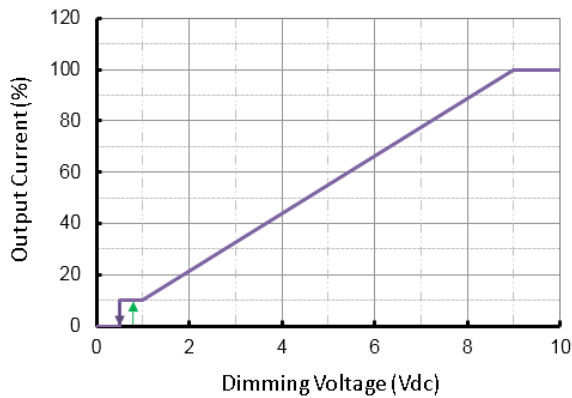

PWM Dimming Curve

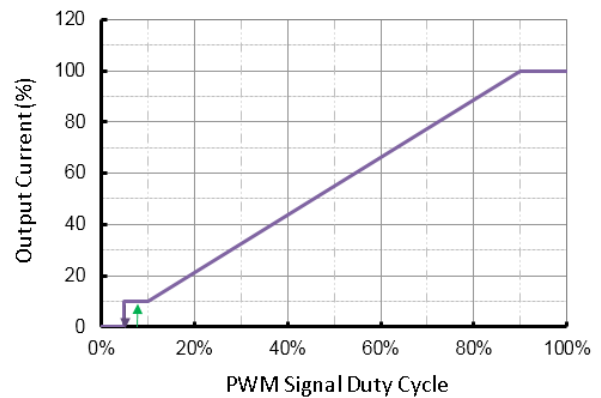

- Dimming Wiring

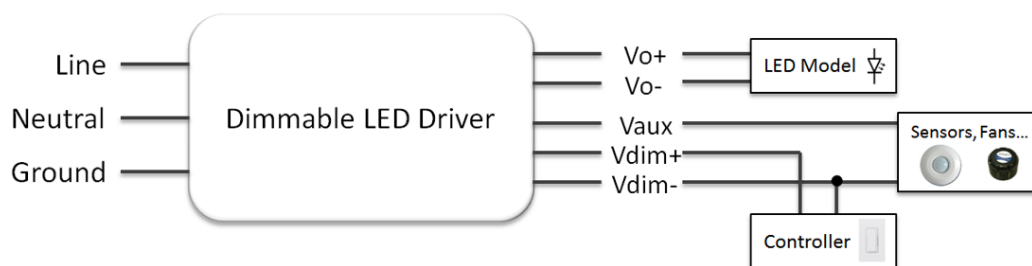

■ **Lifetime vs. Case Temperature**

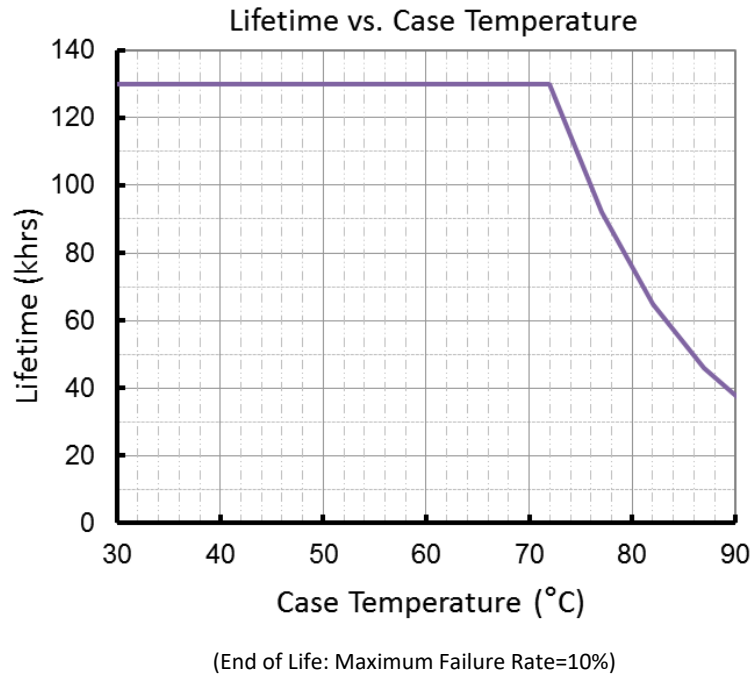

■ **Power Factor vs. Load**

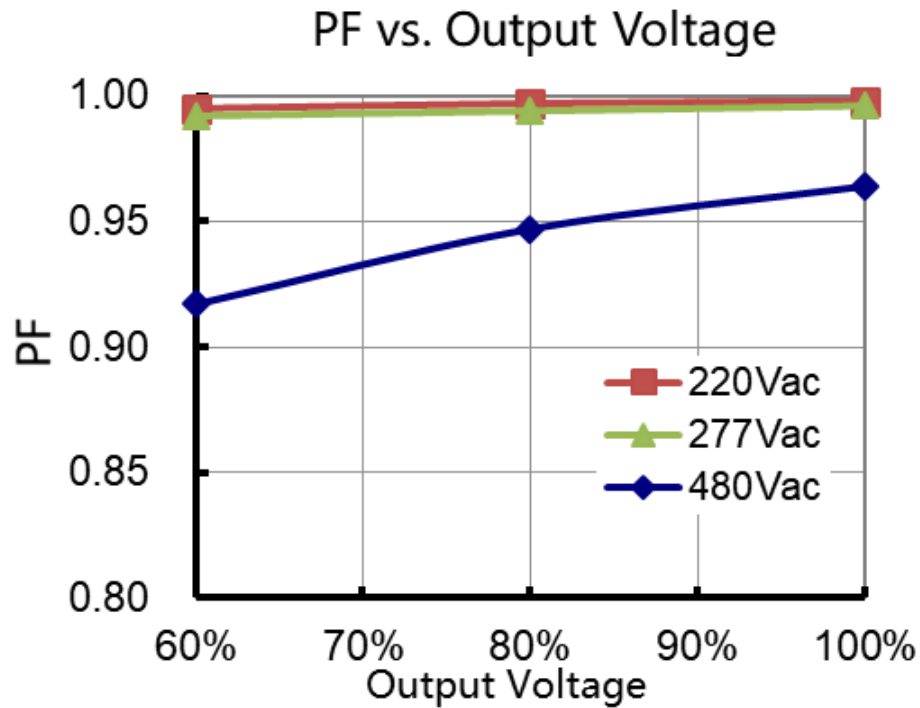

■ THD vs. Load

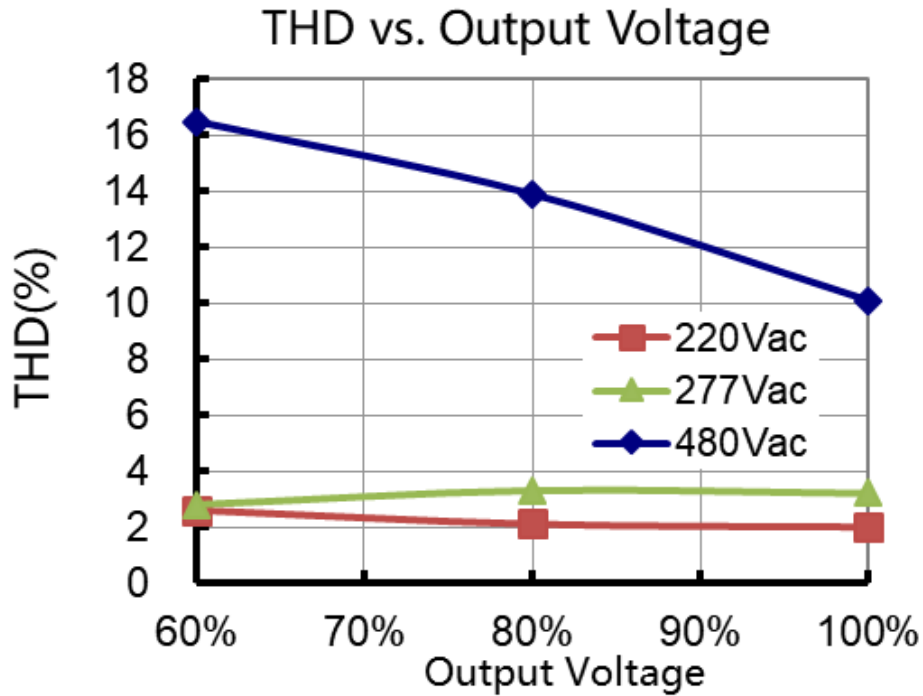

■ Efficiency vs. Load (18A Model)

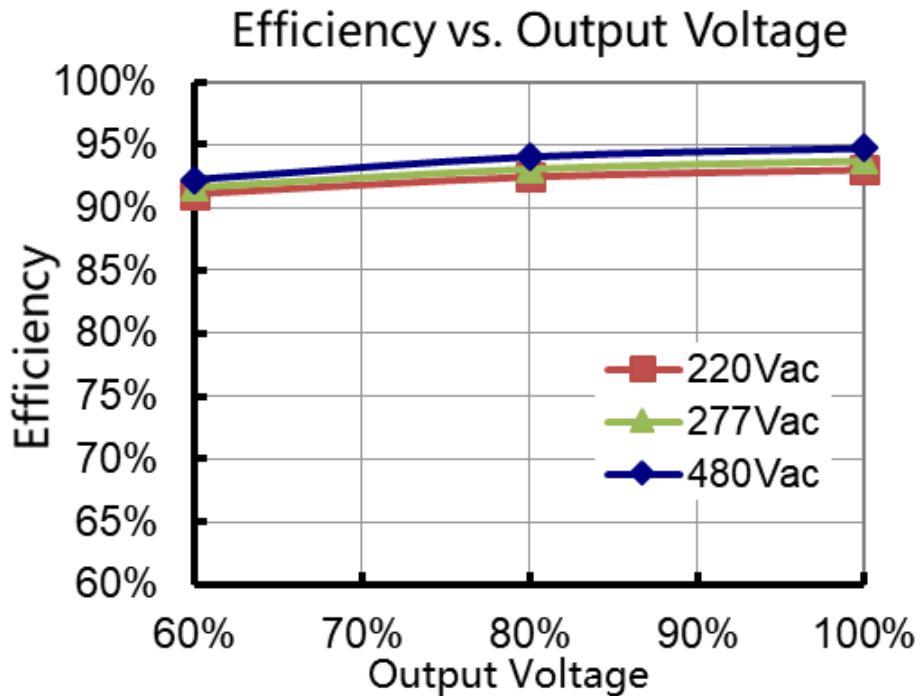

TLD-800-C Series

■ Mechanical Design

- TLD-800-Cxxx-NNU/TRU

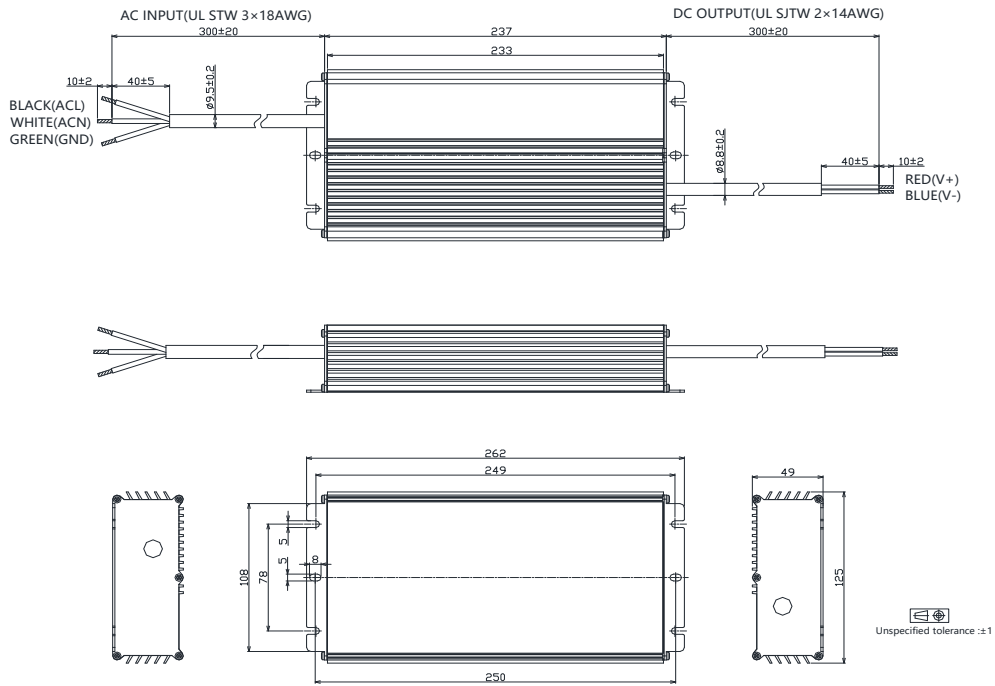

- TLD-800-Cxxx-DNU/DRU

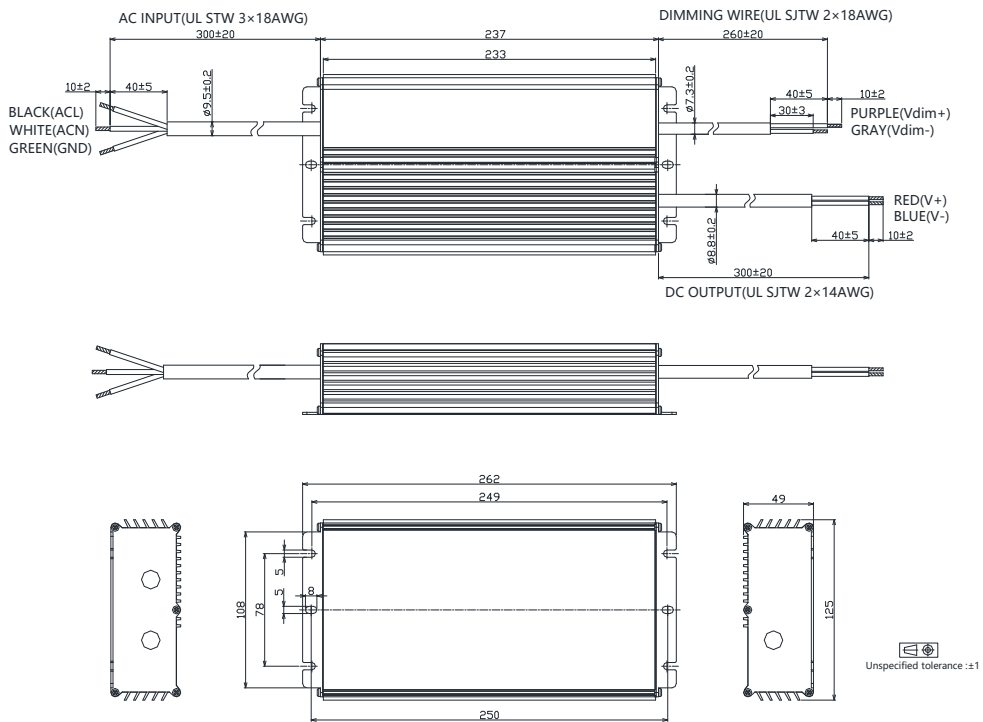

TLD-800-C Series

- TLD-800-Cxxx-ANU/ARU

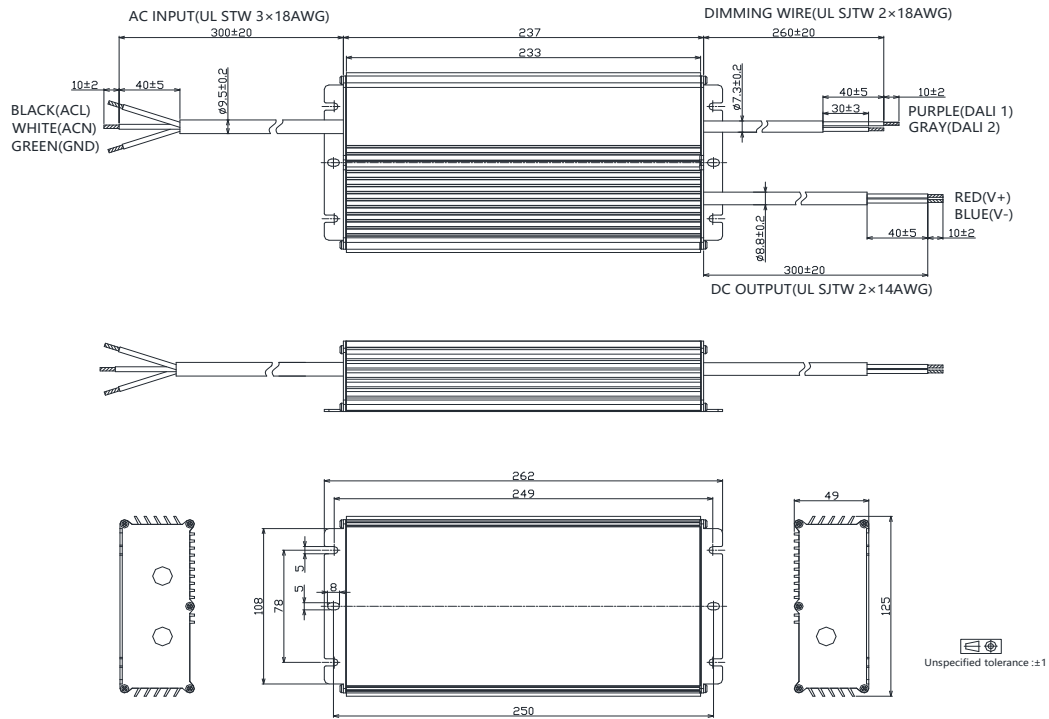

- TLD-800-Cxxx-ENU/ERU

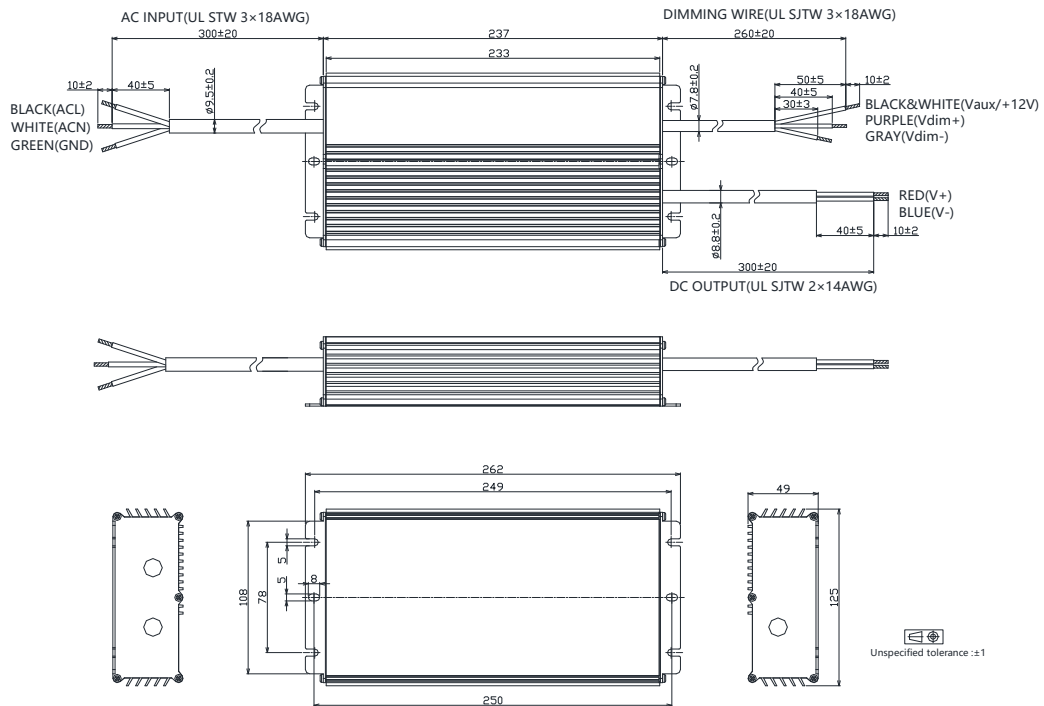

- TLD-800-Cxxx-MRU

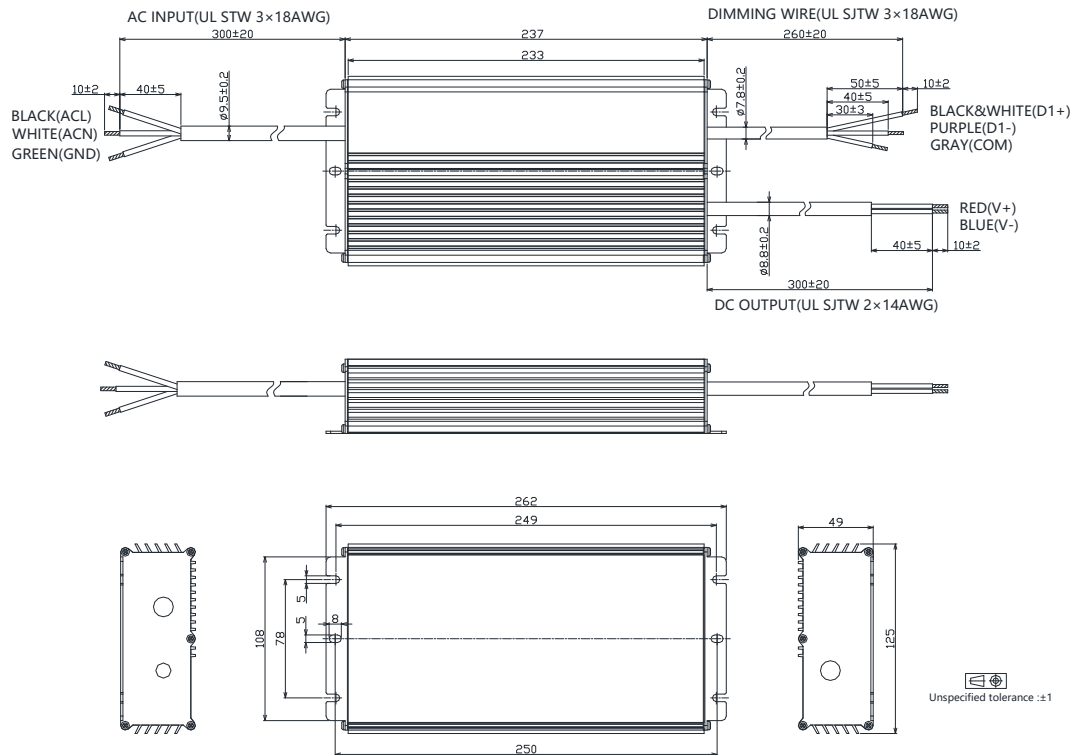

- TLD-800-Cxxx-NNS/TRS (MODELS WITH HIGHER THAN 60V OUTPUT VOLTAGE)

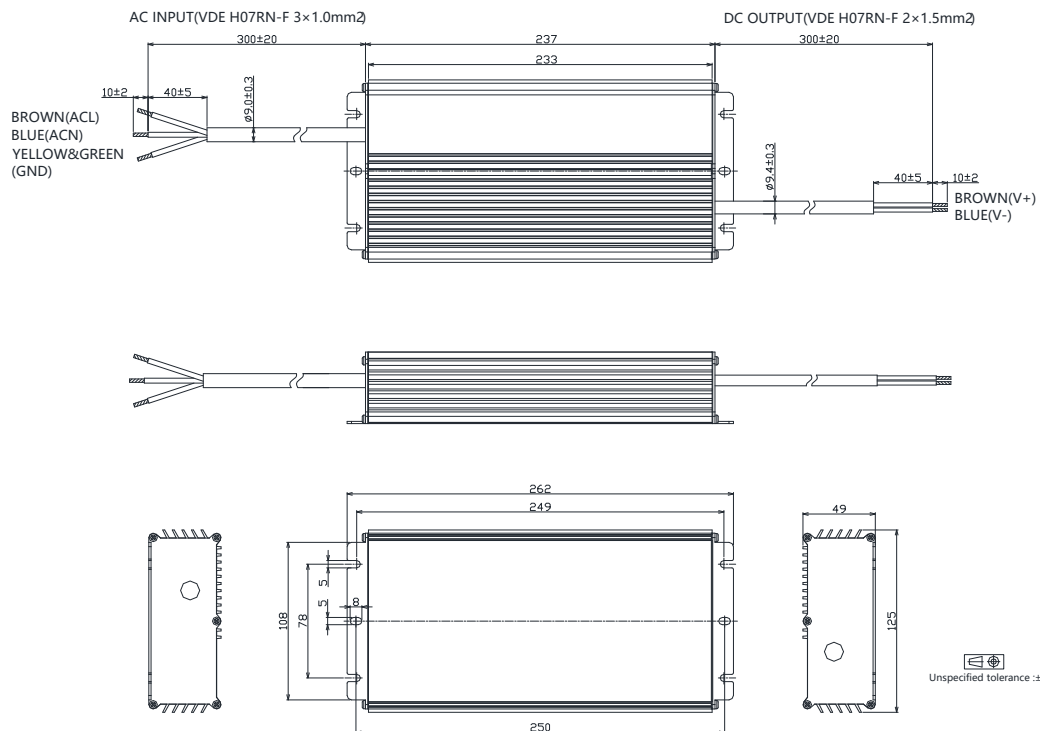

TLD-800-C Series

- TLD-800-Cxxx-DNS/DRS (MODELS WITH HIGHER THAN 60V OUTPUT VOLTAGE)

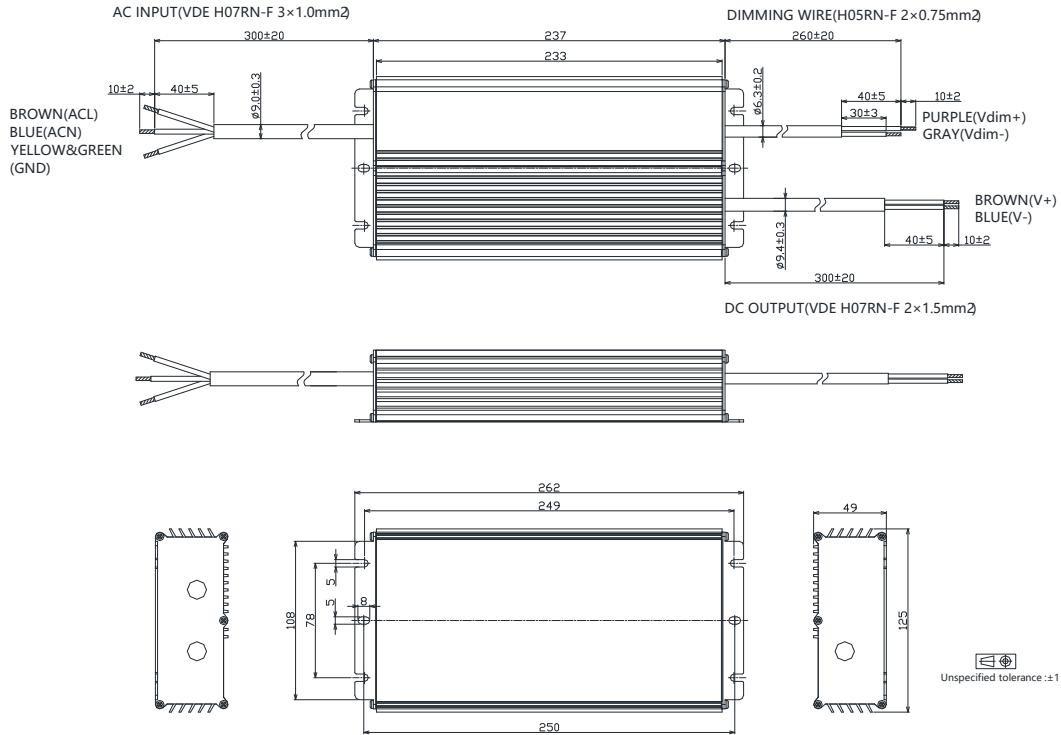

- TLD-800-Cxxx-ANS/ARS (MODELS WITH HIGHER THAN 60V OUTPUT VOLTAGE)

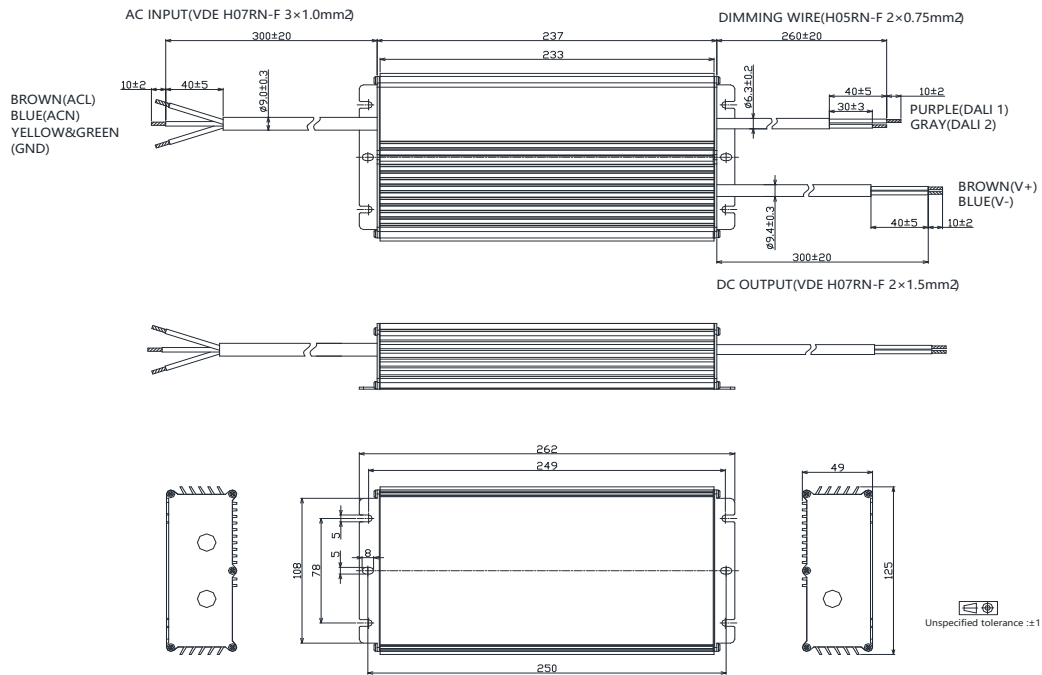

TLD-800-C Series

- TLD-800-Cxxx-ENS/ERS (MODELS WITH HIGHER THAN 60V OUTPUT VOLTAGE)

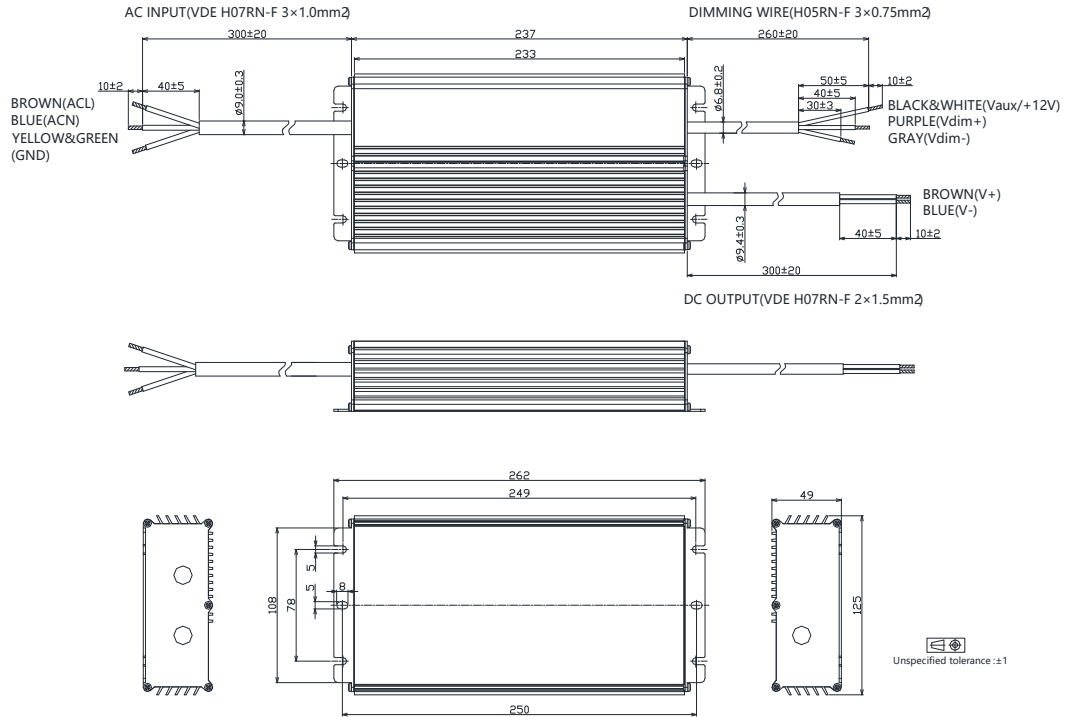

- TLD-800-Cxxx-MRS (MODELS WITH HIGHER THAN 60V OUTPUT VOLTAGE)

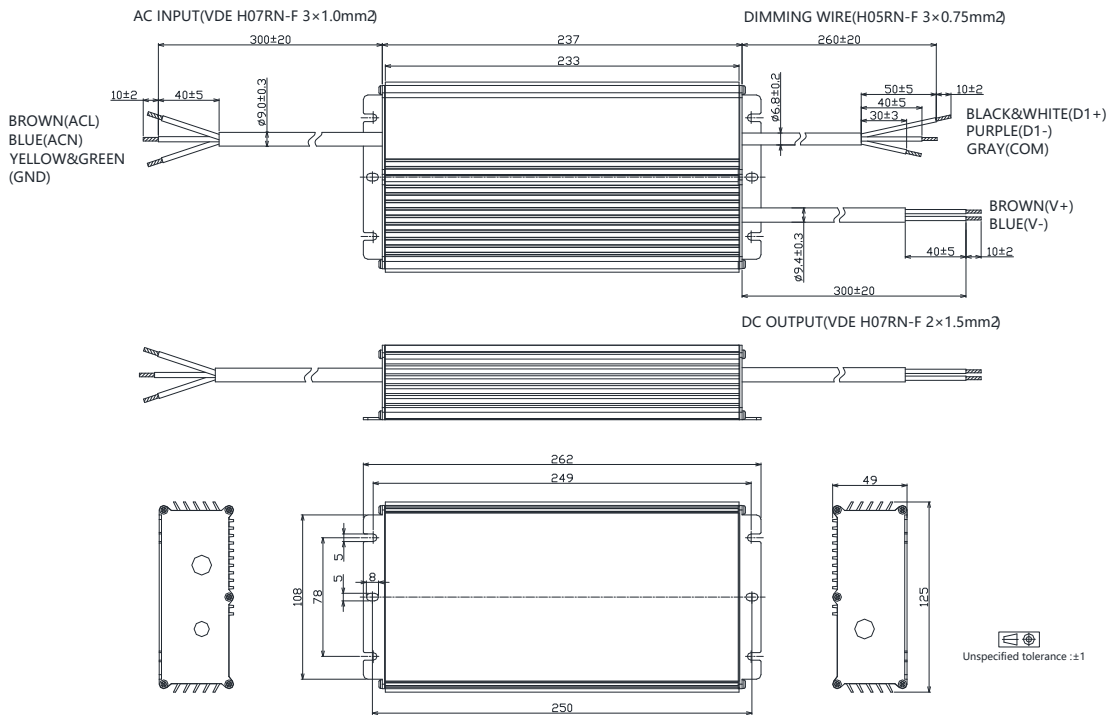

TLD-800-C Series

- TLD-800-C18A-NNS/TRS

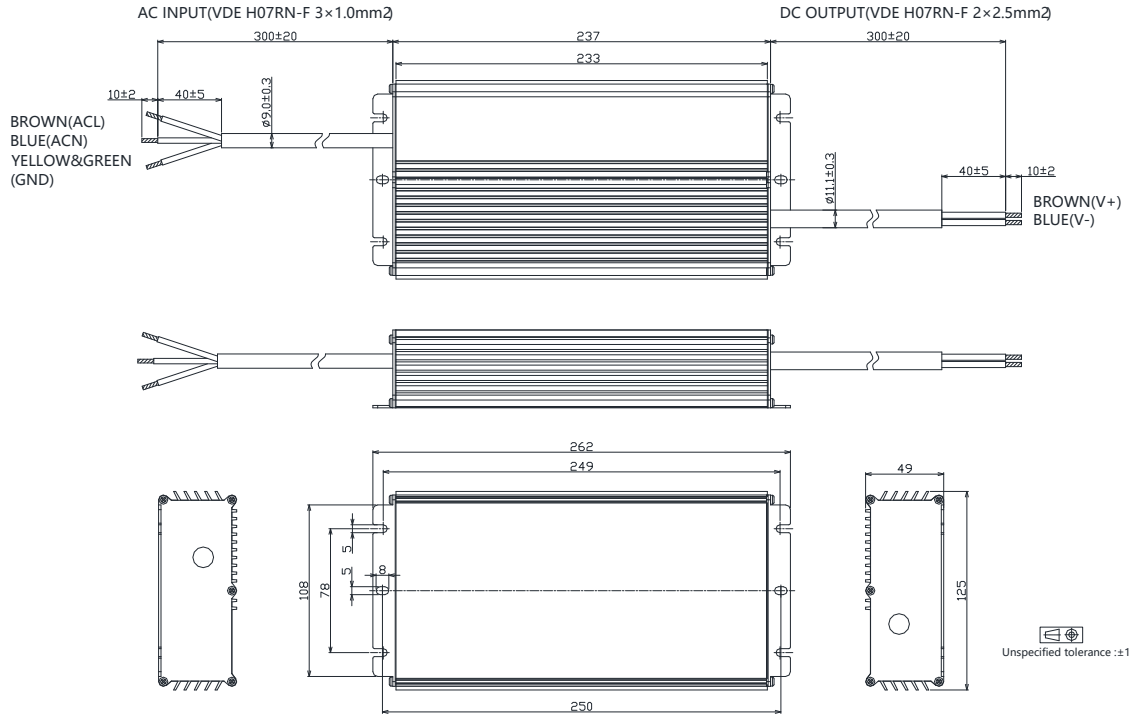

- TLD-800-C18A-DNS/DRS

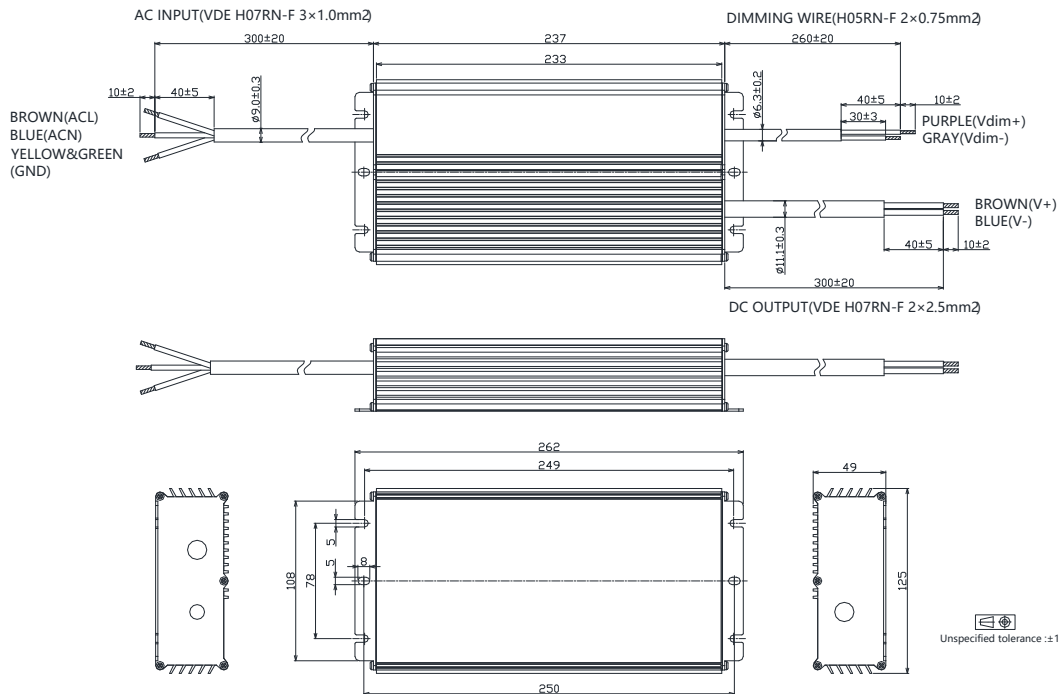

TLD-800-C Series

- TLD-800-C18A-ANS/ARS

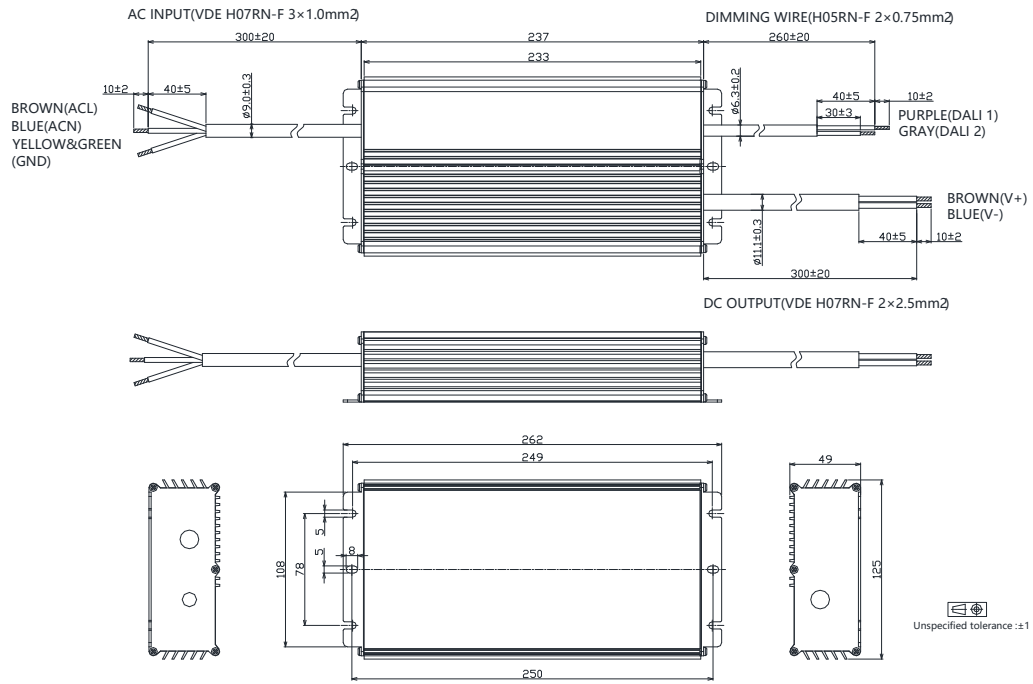

- TLD-800-C18A-ENS/ERS

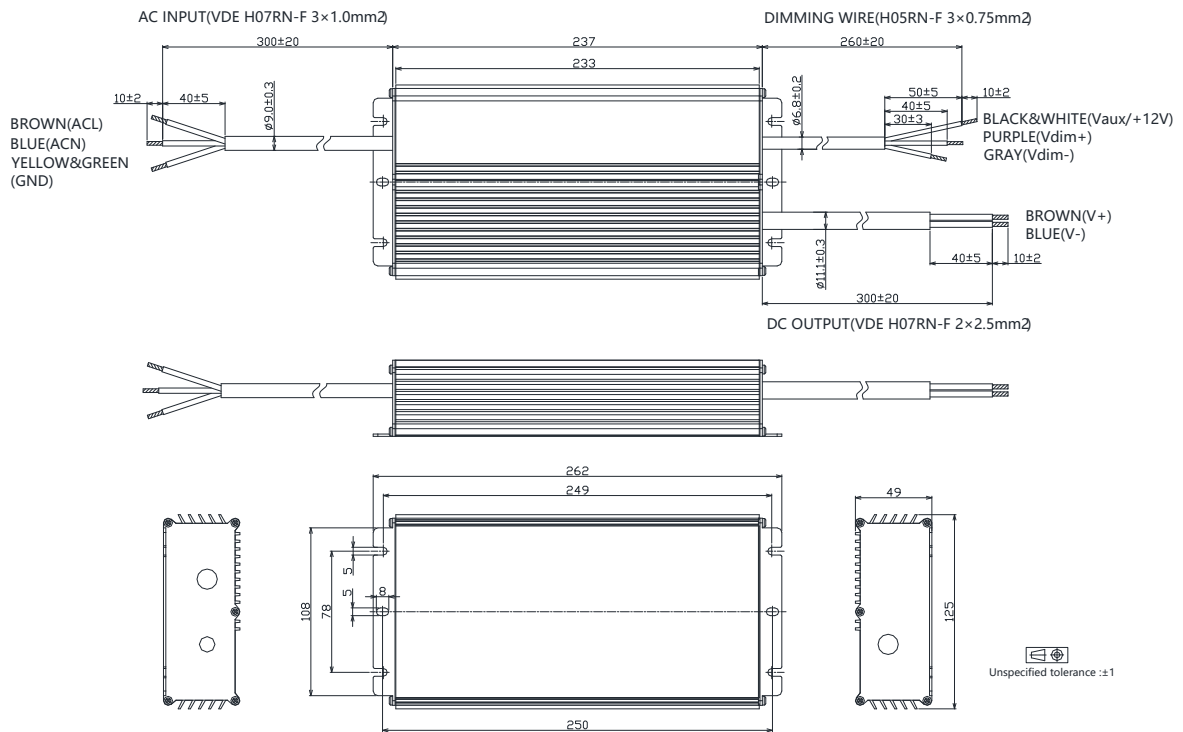

TLD-800-C Series

- TLD-800-C18A-MRS

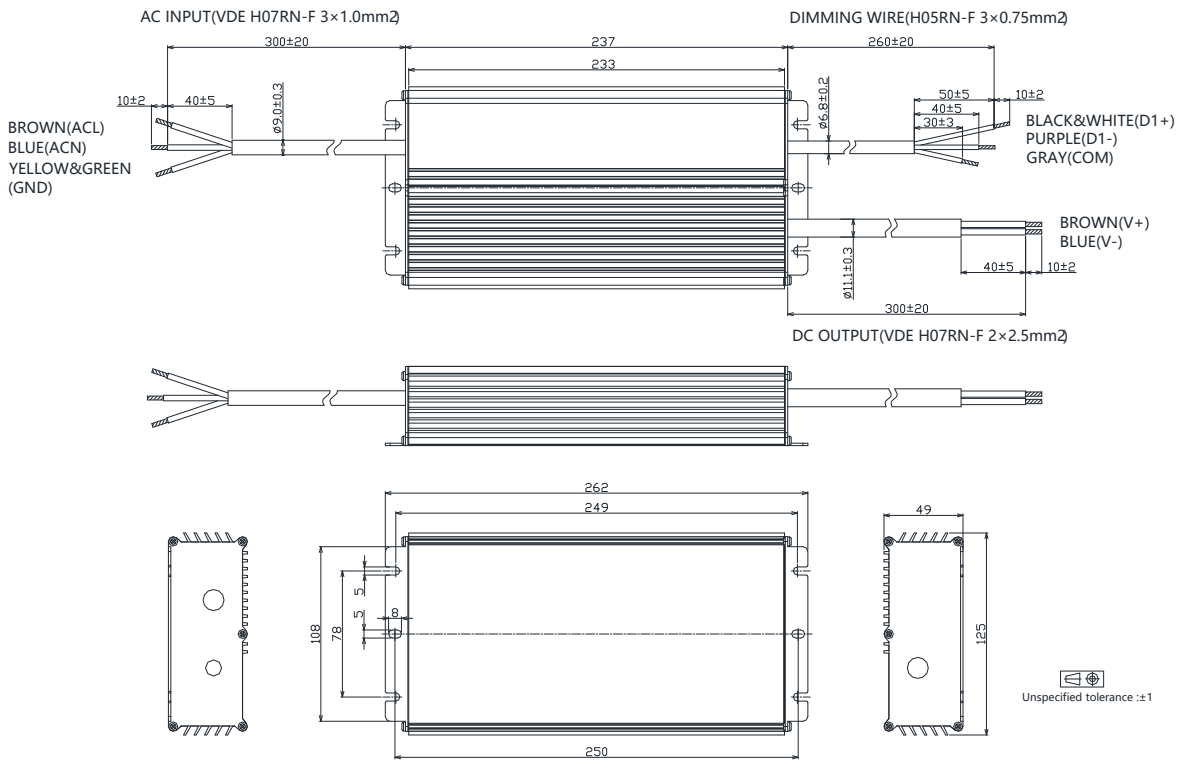

- Customized Functional End Cap Version

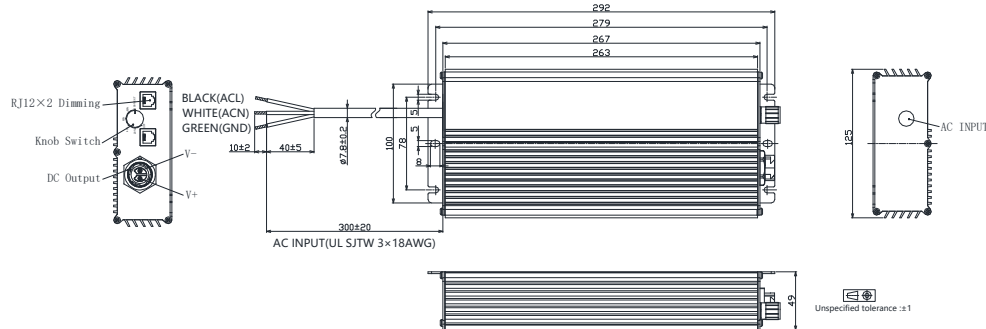

- Add suffix #abcd00 to the end of part number to indicate different configuration.

Item	Value Definition	Description
Input	a	F: M19 waterproof connector P: C14 plug N: Same cable as standard version
Output	b	F: M19 waterproof connector, 2 pins N: Same cable as standard version
Dimming	c	F: M12 waterproof connector R: RJ12 x 2 S: 3.5mm multi-media plug N: Same cable as standard version
Knob	d	K: Knob with steps B: Knob without steps N: No knob

- RJ12 Pin Description

Pin	Description
1,6	12V Aux-power
2,5	Dim+
3,4	Dim-/RTN

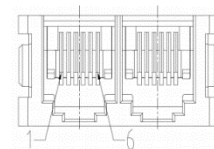

- Knob Description:

Position	Description
100%/EXT	If there is no external control, 100% output. If there is external control, output is controlled by external signal.
Off,20%,40%,60%,80%	External signal invalid.

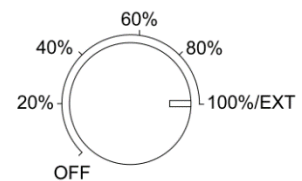

■ Appendix – Operation Range

Model	Typical Set Output Current (mA)	Max Output Power (W)	Output Voltage Min (V)	Output Voltage Max(V)	Minimum Dimming Current (mA)
-C18A	18000	800	30	45	1800
	17000	800	30	48	1700
	16000	800	30	51	1600
	15000	800	32	54	1500
	14500	800	34	56	1450
	14000	782	34	56	1450
	12000	670	34	56	1450
	10000	559	34	56	1450

	1450	80	34	56	1450

Model	Typical Set Output Current (mA)	Max Output Power (W)	Output Voltage Min (V)	Output Voltage Max(V)	Minimum Dimming Current (mA)
-C860	8600	800	56	93	860
	8500	800	56	94	850
	8400	800	57	95	840
	8200	800	59	98	820
	8000	800	60	100	800
	7800	800	62	103	780
	7600	800	63	105	760
	7400	800	65	108	740
	7200	800	67	111	720
	7000	800	69	114	700
	6800	800	71	118	680
	6600	800	73	121	660
	6400	800	75	125	640
	6200	800	77	129	620
	6000	800	80	133	600
	5800	773	80	133	600
	5600	747	80	133	600

	600	80	80	133	600

TLD-800-C Series

Model	Typical Set Output Current (mA)	Max Output Power (W)	Output Voltage Min (V)	Output Voltage Max(V)	Minimum Dimming Current (mA)
-C600	6000	800	80	133	600
	5800	800	83	138	580
	5600	800	86	143	560
	5400	800	89	148	540
	5200	800	92	154	520
	5000	800	96	160	500
	4800	800	100	167	480
	4600	800	104	174	460
	4400	800	109	182	440
	4200	800	114	190	420
	4000	762	114	190	420
	3800	724	114	190	420
	3600	686	114	190	420

	420	80	114	190	420

Model	Typical Set Output Current (mA)	Max Output Power (W)	Output Voltage Min (V)	Output Voltage Max(V)	Minimum Dimming Current (mA)
-C420	4200	800	114	190	420
	4100	800	117	195	410
	4000	800	120	200	400
	3900	800	123	205	390
	3800	800	126	211	380
	3700	800	130	216	370
	3600	800	133	222	360
	3500	778	133	222	360
	3400	756	133	222	360
	3300	733	133	222	360
	3200	711	133	222	360
	3100	689	133	222	360
	3000	667	133	222	360
	2900	644	133	222	360
	2800	622	133	222	360
	2700	600	133	222	360

	360	80	133	222	360